

norstar

Norstar-PLUS (OX32)

Modular ICS Release 1-T1

Installation Guide

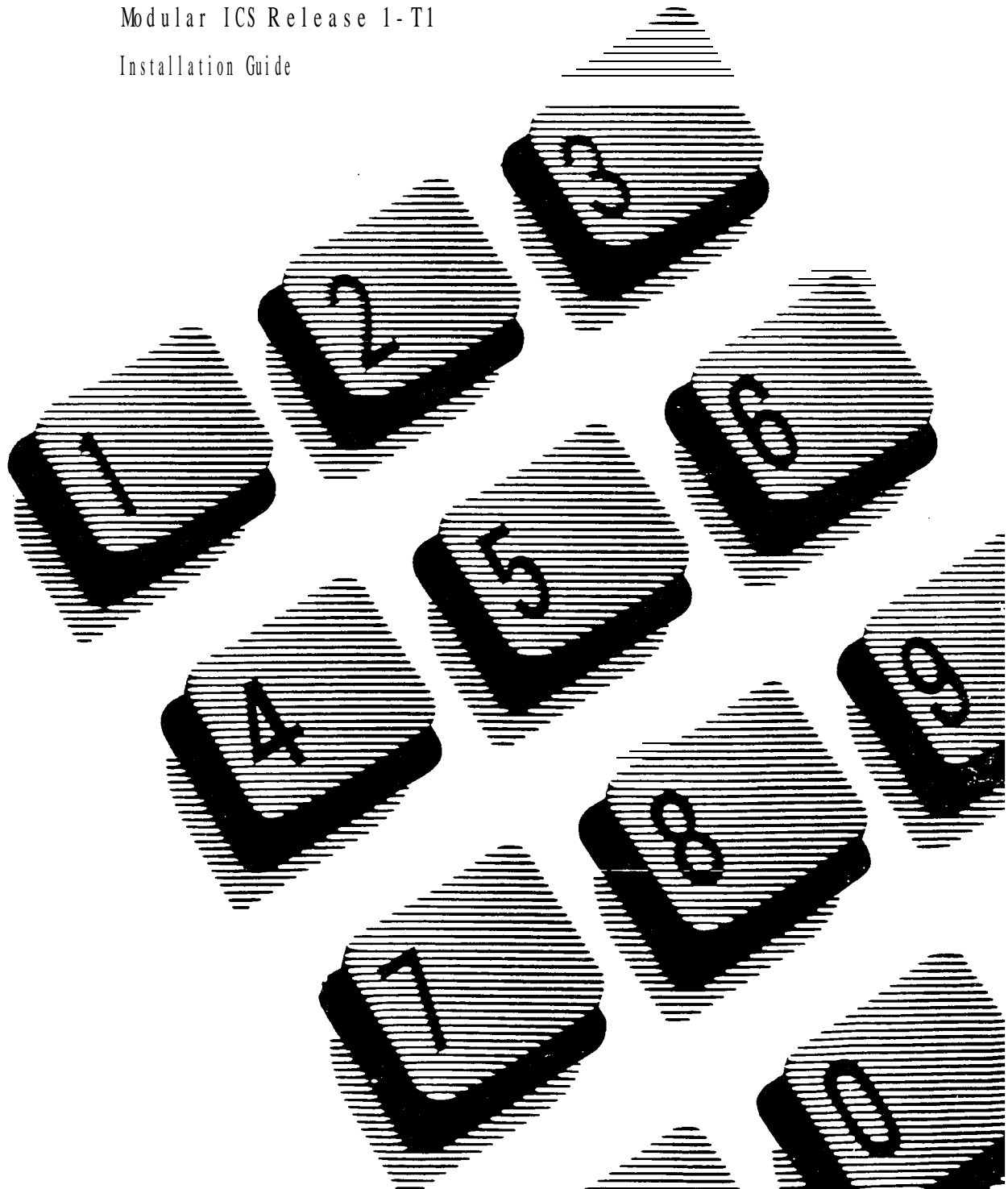

Contents

Regulations 1

- Radio-frequency interference 1
- Registration 1
- Interconnect 1
- Ringer Equivalence Number 2
- Hearing-aid compatibility 2
- Electromagnetic compatibility 2
- Safety 2
- Telephone company registration 3
- Use of a music source 4
- Rights of the telephone company 4
- Repairs 5

What's new with Norstar 7

- New equipment 7
- Enhanced unified dialing in a network 7
- New network transparency 8
- Expanded dialing filters 8
- External calls on intercom keys 9
- Expanded Service Modes 9
- New template 9
- New Calling Line ID on E&M and DID trunks 9
- Expanded Configuration and Maintenance programming 9

Networking with Norstar 11

- The Big Picture 11
- Norstar as an OPX 12
- Trunks and target lines 13
 - Loop start trunks 13
 - E&M trunks 15
 - DID trunks 17
 - Target lines 18
- Remote system access 19
 - Remote access on loop start and E&M trunks 19
 - Remote access on a private network 20
 - Remote access on Direct Inward Dial (DID) trunks 20
- Benefits 21
 - Security 21

- Transparent dialing plan 24
 - Customer Use 28
 - In the public network 29
 - In the private network 33
 - In the Norstar system 36
-

Planning the installation 41

- Planning checklist 41
 - Required equipment and supplies 41
 - Optional equipment 43
 - Equipment for installing the KSU and expansion modules 43
 - Location requirements 43
 - Electrical requirements 44
 - Internal wiring requirements 44
 - Spacing requirements 45
-

Installation 47

- Installation checklist 47
- Mounting the modules 48
- Installing the cartridges 49
 - Installing the Feature Cartridge 51
 - Installing cartridges 52
- Connecting expansion modules 54
 - Order of expansion module connection 54
 - Installing fiber cables 55
- Connecting the wiring 57
 - Connecting the wiring to the distribution panel 60
 - Wiring charts 60
- Installing telephones 77
 - Installing the emergency telephone 77
 - Installing Norstar telephones 78
- Installing optional equipment 81
 - Auxiliary ringer (customer supplied) 81
 - External music source (customer supplied) 81
 - External paging system (customer supplied) 82
- Powering up the system 83

Programming 85

- Programming tools 86
- Exiting programming 88
- Entering numbers 89
- Viewing long telephone numbers 89
- Reviewing programmed settings 90
- Template defaults 91
 - Startup defaults 91
 - Configuration defaults 91
 - General Administration defaults 97
- Startup programming 103
 - Performing Startup 103
- Maintenance programming 106
 - Choosing the clock source for your DTIs 106
 - Provisioning your T1 lines 108
- Configuration programming 110
 - Entering Configuration 110
- Trk/Line Data 111
 - Copying Trunk and Line data 112
 - TCs on 113
 - TC1 on KSU 113
 - TC1 on TM3 114
 - Trunk data 118
 - Line data 125
- Line Access 129
 - Line assignment 129
 - ILG assignment 130
 - Answer DN's 131
 - Line pool access 131
 - Intercom keys 132
 - Prime line 132
- Routing 134
 - Define routes 136
 - Dest codes 137
- Call Handling 139
 - Heid reminder 139
 - Remind delay 139
 - DRT to prime 140
 - DRT delay 140
 - Trnsfr Callbck 140

iv / Contents

Park prefix	140
Park timeout	141
Camp timeout	141
Directd pickup	141
On hold	142
Miscellaneous	143
Backgrnd music	143
Direct-dial #	144
DISA DN	144
Auto DN	145
Alarm set	145
CAP assignment	145
Link time	146
Set relocation	146
Host delay	147
Receiver volume	147
External code	148
Line pool codes	148
Installer pswd.	149
System Data	150
Individual DNs	150
DN length	151
Rec'd # length	152
Set copy	153
Copying set programming	155
Applying button cap labels	156
Applying the button cap labels	156
Identifying the telephones	156
Norstar default button assignments	157

Testing 161

Verifying wiring connections	161
Verifying that all modules are enabled	161
Verifying that all ports are enabled	161
Testing the emergency telephones	161
Testing the Norstar telephone operations	162
Testing the external lines	162
Testing the T1 lines	162
Testing the optional equipment	162
Testing Norstar system programming features	163
Testing Automatic Telephone Relocation	163

Troubleshooting 165

- Getting ready 165
- Types of problems 166
- General troubleshooting procedure 166
- Problems with telephones 168
 - Norstar telephone display unreadable 168
 - Norstar telephone dead 168
 - Emergency telephone dead 170
- Problems with lines 171
 - Calls cannot be made (but can be received) 171
 - Dial tone absent on external lines 172
 - Hung lines at a telephone 172
 - Auto-answer line rings at a Norstar telephone 173
 - Prime telephone gets misdialed calls 174
 - Selected line reads **Not in service** or **Not available** 175
 - Selected line pool shows **No free lines** 177
- Problems with optional equipment 178
 - Analog Terminal Adapter 178
 - Auxiliary ringer 178
 - External paging 179
 - Music on Hold/Background Music trouble 180
- Problems with modules 181
 - Trunk Cartridge trouble 181
 - Digital Trunk Interface trouble 182
 - KSU down 185
 - Trunk Module down 186
 - Station Module down 186
- Problems for network or remote users 188
 - Remote feature code gets no response 188
 - Dialed number gets ringback and the wrong person 188
 - Dialed number gets stuttered dial tone instead of ringback 189
 - Dialed number gets dial tone instead of ringback 189
 - Dialed number gets busy tone 190
 - Dialed number does not get through 190
 - Dialed DISA number gets ringback instead of stuttered dial tone 192
 - Dialed DISA number gets dial tone instead of stuttered dial tone 192

- DISA user gets overflow tone when entering COS password 193
- Dialed feature code gets overflow tone 194
- Dialed feature code gets busy tone 194
- Line pool access code gets overflow tone 195
- Line pool access code gets ringback 196
- Line pool access code gets busy tone 196
- Dialed number gets no response 197

Maintenance 199

- Maintenance overview 199
- Beginning a Maintenance session 200
- System Version 201
 - Checking the version of the system 201
- Port/DN Status 202
 - Identifying a device connected to the system 203
 - Checking the version number of the device 204
 - Checking the state of the device 205
 - Disabling a device 206
 - Enabling the device 207
 - Returning to the beginning 207
- Module Status 208
 - Looking at the module inventory 209
 - Checking the number of Trunk Cartridges attached to a module 209
 - Checking the state of a module 210
 - Checking the state of a cartridge 211
 - Disabling a module or its cartridges 211
 - Enabling a module or its cartridges 211
 - Returning to the beginning 211
- System Test Log 212
 - Checking the items in the log 212
 - Checking the current alarm 213
 - Checking when each item in the log occurred 213
 - Checking the number of consecutive repetitions of an event or alarm 213
 - Erasing the log 213
- System Administration Log 214
 - Checking the items in the log 214
 - Checking the current alarm 214
 - Checking when each item in the log occurred 214

Erasing the log	215
Network Log	216
Checking the items in the log	216
Checking the current alarm	216
Erasing the log	217
Checking when each item in the log occurred	217
Alarm codes	218
If you see an alarm code	218
Alarm troubleshooting	220
Event messages	223
Dealing with event messages	223
Significant event messages	223
Clock Source	228
Setting the clock source for your DTIs	232
Provisioning	234
Provisioning a line	234
Deprovisioning a line	234
Loopback Tests	235
Tests initiated from Norstar	238
Tests initiated by the central office	238
Starting a line, payload or card edge loopback test	239
Stopping a line, payload or card edge loopback test	240
Starting or stopping a continuity loopback test	240
CSU Stats	241
Statistics	241
Checking the performance statistics	242
Checking the CSU alarms	243
Resetting all statistics	245
Maintenance records	246
Recording information on the Maintenance records	246
Version number record	247
System Test Log record	248
System Administration Log record	249
Network Log record	250

Specifications 251

Upgrading your system 257

Upgrading your hardware	257
Upgrading your software	262

viii / Contents

Glossary 265

Index 283

Regulations

Radio-frequency interference

	<p style="text-align: center;">Equipment generates RF energy</p> <p>This equipment generates, uses, and can radiate radio-frequency energy. If not installed and used in accordance with the instruction manual, it may cause interference to radio communications. It has been tested and found to comply with the limits for a Class A computing device pursuant to Part 15 of the FCC Rules and with CSA C108.8, which are designed to provide reasonable protection against such interference when operated in a commercial environment. Operation of this equipment in a residential area is likely to cause interference, in which case the user, at his own expense, will be required to take whatever measures may be required to correct the interference. Each Norstar key telephone system is assigned an FCC registration number and a ringer equivalence designation. The number and designation are printed on the Key Service Unit (KSU) label.</p>
---	---

Registration

The Norstar key telephone system is registered with the FCC based upon compliance with Part 68 of its rules. Connection of the Norstar key telephone system to the nationwide telecommunications network is made through a standard network interface jack that you can order from your telephone company. Jacks for this type of customer-provided equipment will not be provided on party lines or coin lines.

Interconnect

Norstar equipment meets all applicable requirements of both the Canadian Department of Communications CS-03 and US Federal Commission FCC Part 68 and has been registered under files DOC 332-5980 A and FCC AB6CAN-20705-KF-E (key system) and AB6CAN-20706-MF-E (hybrid system).

2 / Regulations

A DOC label identifies certified equipment. Certification means that the equipment meets certain telecommunications network protective, operational and safety requirements. It does not guarantee that the equipment will operate to the user's satisfaction.

Ringer Equivalence Number

The FCC Registration Label, on the front of the Key Service Unit (KSU), includes the ringer equivalence number (REN). This number shows the electrical load that your Norstar KSU requires from your telephone line. If the KSU requires more electrical current than your telephone company's central office equipment can provide, your telephones may not ring and you may have difficulty dialing telephone numbers.

Call the telephone company to find out the total REN allowed for your telephone line(s).

Hearing-aid compatibility

Norstar telephones are hearing-aid compatible, as defined in Section 68.316 of Part 68 FCC Rules.

Electromagnetic compatibility

Norstar Modular equipment meets all FCC Part 15, class A radiated and conducted emissions requirements.

This digital apparatus does not exceed the Class A limits for radio noise emissions from digital apparatus set out in the Radio Interference Regulations of the Canadian Department of Communications.

Safety

Norstar Modular equipment meets all applicable requirements of both the Canadian Standards Association C22.2 No. 225-M1991 and US Underwriter's Laboratory UL-1459 Issue 2, and has been registered under files CSA LR58855 and UL E 115515.

Telephone company registration

It is usually not necessary to call the telephone company with information on the equipment before connecting the Norstar Key Service Unit (KSU) to the telephone network. If the telephone company requires this information, provide the following:

- telephone number(s) to which the Key Service Unit (KSU) will be connected
- FCC registration number (on label affixed to KSU)
- ringer equivalence number (REN)
- universal service order code (USOC)
- service order code (SOC)
- facility interface code (FIC)

Before installing the equipment, the user should ensure that it is permissible to connect it to the local telephone company facilities. The equipment must be installed using an acceptable method of connection. However, using an acceptable method of connection may not prevent degradation of service in some situations.

Trunk Cartridge	REN	USOC	SOC	FIC
Loops Start - NT7B75GA-93 Call Information - NT5B41GA-93	AC 1.5B DC 0.3	RJ21X	9.0F	02LS2
DTI - NT7B74GA-93	0.0	RJ48C	6.0Y	04DU9-1SN
E&M - NT5B38GA-93	0.0	RJ2HX	9.0F	TL32M
DID - NT5B37GA-93	0.0B	RJ21X	9.0F	02RV2-T



Notify service provider if DTI is disconnected

You must notify your T1 service provider any time the 1.544 Mbps DTI interface is disconnected from the network.

Use of a music source

In accordance with U.S. Copyright Law, a license may be required from the American Society of Composers, Authors and Publishers, or similar organization if Radio or TV broadcasts are transmitted through the Music On Hold or Background Music features of this telecommunication system.

Northern Telecom Inc. hereby disclaims any liability arising out of the failure to obtain such a license.

Rights of the telephone company

If the system is causing harm to the telephone network, the telephone company may discontinue your service temporarily. If possible, the telephone company will notify you in advance. If advance notice is not practical, the user will be notified as soon as possible. The user will be given the opportunity to correct the situation and you will be informed of your right to file a complaint to the FCC.

The telephone company may make changes in its facilities, equipment, operations or procedures that could affect the proper functioning of your system. If it does this, the user will be notified in advance to give you the opportunity to maintain uninterrupted telephone service.

If the user makes any repairs or alterations to this equipment, or if the equipment malfunctions, the telephone company may request that the equipment be disconnected.

Repairs

In the event of an equipment malfunction, all repairs will be performed by Northern Telecom Inc. or by one of its authorized dealers.

To return equipment for repair in the U.S.A., call 1-800-321-2649.

Address of a repair facility

USA

Northern Telecom Inc.
Nashville Repair Distribution Center
640 Massman Drive
Nashville, TN
37210
RA# _____

Canada

Northern Telecom Canada Ltd.
Customer Service Dept. 925
150 Montréal-Toronto Blvd.
Building C, Doors 33 and 34
Lachine, Québec H8S 1B6

6 / Regulations

What's new with Norstar

New equipment

The Norstar 0X32 system has new equipment with improved performance to meet your growing telecommunication needs.

KSU and modules

The 0X32 Key Service Unit (KSU) supports up to 32 Norstar telephones and has two slots for Trunk Cartridges. You can install any combination of Digital Trunk Interfaces (DTI) to provide up to 48 digital T1 trunks, or Loop Start or Call Information (CI) Trunk Cartridges to provide up to eight analog lines. The KSU also has slots for the one-piece Feature Cartridge, the Services Cartridge (required for T1 trunks), and the slim Expansion Cartridges with fiber connectors. It provides a relay for an auxiliary ringer, an input for Music on Hold, and has a replaceable power supply.

The new Trunk Module and Station Module provide the same basic functionality as the original modules, but have fiber connectors for connection to the slim Expansion Cartridges using fiber cables.

With the new KSU a fully expanded system can now support a maximum of 120 lines or 128 Norstar telephones.

T1 trunks

Norstar now supports digital trunks, allowing your Norstar system to be connected to a digital T1 network. T1 digital trunks provide quality, reliable, and low cost voice communication. The Norstar DTI comes equipped with a built-in channel service unit (CSU) to allow direct connection to the network. If desired, you can disable the internal CSU, and connect the DTI to an external CSU or multiplexer.

Enhanced unified dialing in a network

Norstar has three features that help you provide unified dialing in your network.

DN length

Heading **6. System Data** in Configuration programming allows you to set the length of Norstar directory numbers. You can use this setting to adjust Norstar directory numbers to match the length of the directory numbers used by other systems in your network.

Starting directory number

Heading **Start DN** in Startup programming now lets you determine the starting directory number in your system. You can use this setting to integrate your Norstar directory numbers with the range of directory numbers used by other systems in your network. For example, if system A in your network uses directory numbers 2221 through 2267, and system B in your network uses directory numbers 2268 through 2346, you can set your starting directory number to be 2347.

Routing

Heading **3. Routing** in Configuration programming allows you to create destination codes that when dialed, use selected line pools and dial predetermined digits. In this way you can allow users on your Norstar system to dial what appear to be Norstar directory numbers and have the system automatically dial the external number on a selected line pool. See the Programming chapter for more information.

New network transparency

Norstar offers new transparency to existing features that make calling in a network easier. You can:

- assign a telephone outside your Norstar system as a direct-dial telephone
- transfer calls to another telephone in your network

Expanded dialing filters

You can now use dialing filters to create restrictions for feature codes that access features on other systems or on your central office switch. In certain cases, dialing one of these feature codes can allow a caller to bypass your system's dialing filters. Restricting the feature codes prevents these unauthorized calls.

External calls on intercom keys

An external line can now be programmed to only ring at a telephone. Incoming calls on the line appear on an intercom button at the telephone.

Expanded Service Modes

Service Modes has been expanded. Now in addition to providing alternate ringing arrangements, you can provide alternate dialing filters for lines and telephones, and select alternate routes for calls that use the routing tables. The alternate routing service allows you to select alternate, less expensive routes for calls. The schedule for Service Modes has also been expanded so that you can assign different start and stop times for modes, for every day of the week. The number of modes has been expanded from three to six, giving you greater flexibility in assigning each of the different services. See the *System Coordinator Guide* for more details on Service Modes.

New template

Norstar offers a new DID template in Startup programming. The DID template sets your system up for direct inward dialing by automatically assigning a target line to each set. The received number for each target line is set to match the DN of the telephone it is assigned to. See the Programming chapter for details.

New Calling Line ID on E&M and DID trunks

Norstar receives Auto Number Identification (ANI) to provide Calling Information on E&M and DID trunks. The ANI information is used and displayed as part of Call Display services.

Expanded Configuration and Maintenance programming

Configuration programming and Maintenance have been expanded to accommodate the new capabilities provided by T1 trunks, and to provide some new system features.

10 / What's new with Norstar

Networking with Norstar

In addition to public network connections, Norstar can be integrated into an existing private network or to other Norstar systems to form a corporate telecommunications network.

The Big Picture

Norstar uses enhanced trunking to join other Norstar or customer equipment in a private network. Authorized users can also access tie lines, central office lines, and Norstar features from outside the Norstar system.

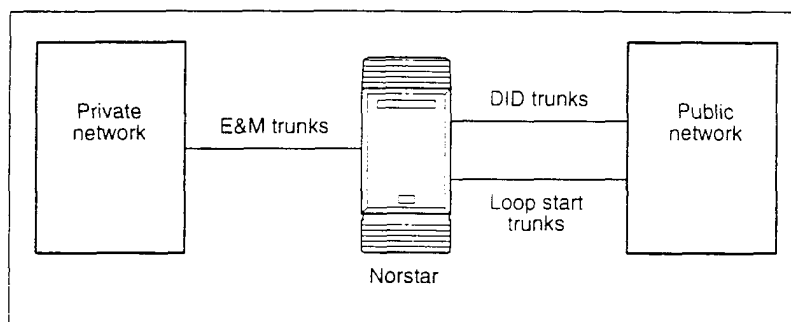

Callers in the Norstar system can:

- call directly to a specific Norstar telephone,
- select an outgoing tie line to access a private network,
- select an outgoing tie line to access features that are available on the private network,
- select an outgoing central office line to access the public network, and
- use all of the Norstar features.

12 / Networking with Norstar

Callers in the public network can:

- call directly to one or more Norstar telephones,
- call into the Norstar system and select an outgoing tie line to access a private network,
- call into the Norstar system and select an outgoing central office line to access the public network, and
- call into the Norstar system and use remote features.

Callers in the private network can:

- call directly to one or more Norstar telephones,
- call into the Norstar system and select an outgoing tie line to access other nodes in a private network,
- call into the Norstar system and select an outgoing central office line to access the public network, and
- call into the Norstar system and use remote features.

Norstar as an OPX

Norstar can be used as an off-premise extension (OPX) from a PBX. In order to support this application, the OPX lines must be engineered not to exceed 8 dB total loop loss from the serving central office to the demarcation point at the Norstar KSU.

Trunks and target lines

Trunks are external lines that provide the physical connection between a Norstar system and other systems in a private or public network. Trunks are numbered 001 to 120 (in a fully expanded system). Norstar supports 4 different types of trunks:

- Loop start trunks handle incoming and outgoing calls between Norstar and the public network.
- E&M trunks handle incoming and outgoing traffic between the Norstar system and the private network.
- DID trunks route incoming calls from the public network directly to telephones within Norstar, without an attendant.
- DTI trunks are digital trunks that can be configured to act as loop start, E&M or DID trunks depending on your requirements.

Target lines are virtual communication paths between trunks and Norstar telephones. They are incoming lines only, and cannot be selected for outgoing calls. With target lines, you can concentrate incoming calls on fewer trunks. Target lines are numbered 201 to 248.

Telephones can be configured to have an appearance of any type of trunk and line (including target lines).

Loop start trunks

Loop start trunks give you incoming and outgoing access to the public network. Loop start trunks can be configured as manual-answer or auto-answer. The answer mode determines how the system handles incoming calls.

When a call comes in on a manual-answer loop start trunk, it alerts at all telephones with that line appearance.

When a call comes in on an auto-answer loop start trunk that is configured to answer with direct inward system access (DISA), the caller hears a stuttered dial tone. They must enter a 6-digit Class of Service password from a DTMF telephone to access system dial tone. Once the caller has system dial tone, they can then enter a target line number, a line pool access code, or a remote feature code.

By default, auto answer loop start trunks are configured to answer with DISA, and are used to provide controlled access to Norstar system resources.

When a call comes in on an auto-answer loop start trunk that is not configured to answer with DISA, the caller hears system dial tone. They can then enter a target line number, the DISA DN (the number that will call for a Class of Service password), a line pool access code, or a remote feature code from a DTMF telephone.

To place an outgoing call, a loop start line can be selected by pressing a line button on the telephone, dialing a line pool access code, or pressing a memory button that has been programmed with a line pool access code.

Tips

Loop start signaling is supported by Loop Start Trunk Cartridges, Call Information (CI) Trunk Cartridges and Digital Trunk Interfaces (DTI). Each Loop Start Trunk Cartridge or CI Trunk Cartridge can provide four loop start trunks. A DTI can provide up to 24 loop start trunks. If you wish to configure your loop start trunks as auto-answer, the trunks must have disconnect supervision.

For Loop Start or CI Trunk Cartridges installed in a Trunk Module, you will also need one E&M/DISA Trunk Cartridge for every two loop start trunks that you configure as auto-answer. The E&M/DISA Trunk Cartridge provides two DTMF receivers to receive the incoming digits from the central office. An auto-answer loop start trunk can give you the same kind of direct inward dialing function as a DID trunk.

If your system includes both loop start trunks and DID trunks, you would typically use loop start trunks for outgoing calls and DID trunks for incoming calls.

You may configure a loop start trunk as the prime line for a Norstar telephone.

The capabilities available to a remote caller are determined by the remote filters and remote package assigned to a line, or by the user filters, line filters and remote package assigned to the Class of Service password.

E&M trunks

An E&M trunk gives you incoming and outgoing access to other systems in a private network. E&M trunks can be configured as manual-answer or auto-answer. The answer mode determines how the system handles incoming calls.

By default, auto-answer E&M trunks are answered by the system with direct inward system access (DISA), and are used to provide controlled access to Norstar system resources.

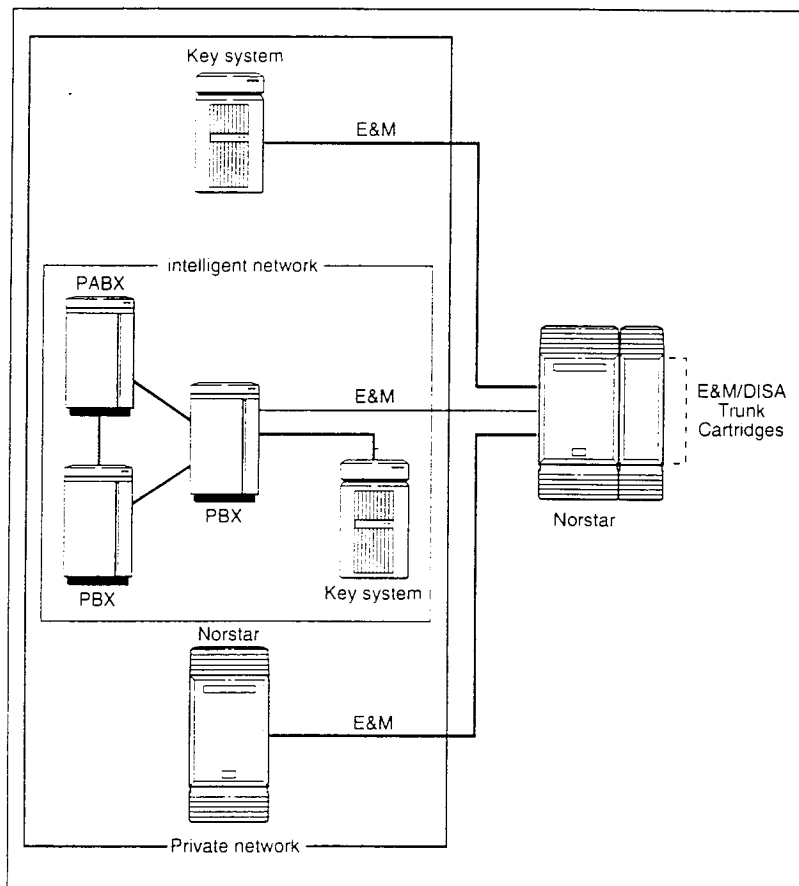

When a call comes in on a manual-answer E&M trunk, it alerts at all telephones with that line appearance.

When a call comes in on an auto-answer E&M trunk that is configured to answer with DISA, the caller hears stuttered dial tone. They must enter a 6-digit Class of Service password from a DTMF telephone to hear system dial tone. They can then enter a target line number, a line pool access code, or a remote feature code.

When a call comes in on an auto-answer E&M trunk that is not configured to answer with DISA, the caller hears system dial tone. They can then enter a target line number, the DISA DN (the number that will call for a Class of Service password), a line pool access code, or a remote feature code from a DTMF telephone.

To place an outgoing call, an E&M trunk can be selected by pressing a line button on the telephone, dialing a line pool access code, or pressing a memory button that has been programmed with a line pool access code.

Tips

Each E&M/DISA Trunk Cartridge can provide two E&M trunks. A DTI can provide up to 24 E&M trunks.

For Loop Start or CI Trunk Cartridges installed in a Trunk Module, you need one E&M/DISA Trunk Cartridge for every two loop start trunks that you configure as auto-answer. The E&M/DISA Trunk Cartridge provides two DTMF receivers to receive the incoming digits from the central office.

You can configure an E&M trunk as the prime line for a Norstar telephone.

The capabilities available to a remote caller are determined by the remote filters and remote package assigned to a line, or by the user filters, line filters and remote package assigned to the Class of Service password.

DID trunks

DID trunks give you direct inward dialing (DID) from the public network. A typical application of these trunks is to map incoming digits onto target line appearances within the Norstar system. DID trunks can operate only as auto-answer trunks.

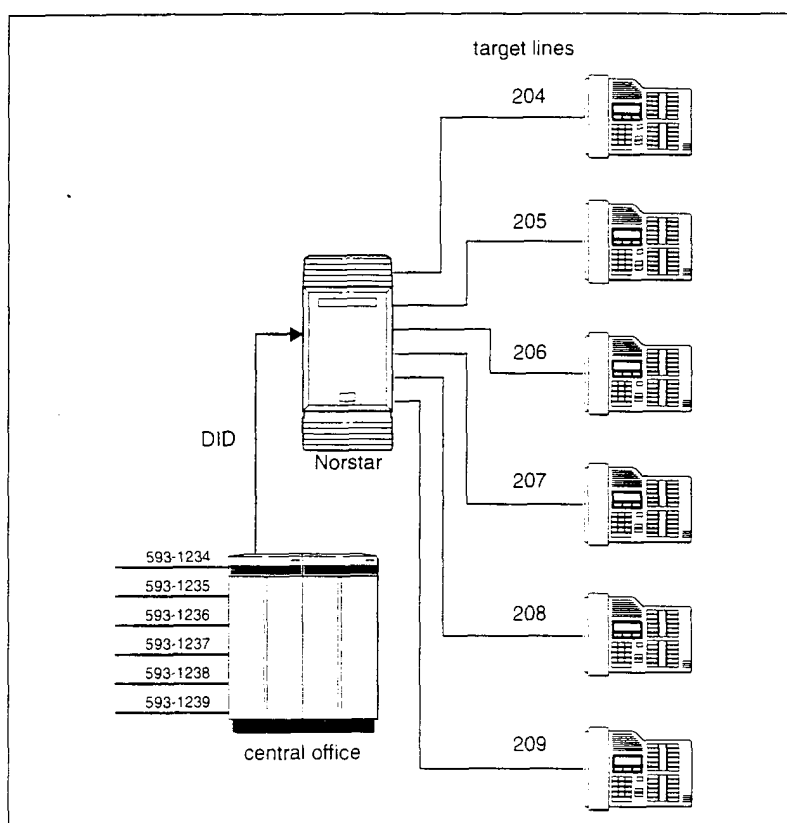

When a call comes in on a DID trunk, the Norstar system interprets the incoming digits in one of the following ways.

- If the digits map onto a target line, the call is routed to all telephones with an appearance of that target line.

- If the digits map onto the DISA DN, the caller hears stuttered dial tone. They must enter a 6-digit Class of Service password from a DTMF telephone to hear system dial tone. They can then enter a target line number, a line pool access code, or a remote feature code.
- If the digits map onto the Auto DN, the caller hears system dial tone. They can then enter a target line number, the DISA DN (the number that will call for a Class of Service password), a line pool access code, or a remote feature code from a DTMF telephone.

Tips

Each DID Trunk Cartridge can provide four DID trunks. Each DID Trunk Cartridge also has four DTMF receivers dedicated to those trunks. A DTI can provide up to 24 DID trunks.

You cannot configure a DID trunk as the prime line for a Norstar telephone.

The capabilities available to a remote caller are determined by the remote filters and remote package assigned to a line, or by the user filters, line filters and remote package assigned to the Class of Service password.

Target lines

A target line is a specific communication path that is reached by means of digits received from an incoming trunk. Target lines are used to answer incoming calls but cannot be used to make outgoing calls.

You can program auto-answer loop start and E&M trunks, and DID trunks to map to target lines to provide for attendant bypass (calling directly to a department or individual) and line concentration (one trunk can map onto several target lines).

With all templates except the DID template, by default no target lines are assigned to sets.

Target lines are referred to by line numbers (121-248) in the same way as physical lines.

Remote system access

The remote access feature allows callers elsewhere on a private network, or on the public network, to access a Norstar system by dialing directly without going through an attendant. Once on the system, the remote user can use some of the system's resources.

Norstar systems support remote system access on the following trunk types which may require the remote caller to enter a password for direct inward system access (DISA):

- auto-answer loop start trunks
- auto-answer E&M trunks
- DID trunks (by means of the DISA DN).

The system resources (dialing capabilities, line pool access and feature access) that a remote user may access depends on the Class of Service assigned to them. Refer to the description of Class of Service in the *System Coordinator Guide* for more details.

Remote access on loop start and E&M trunks

Loop start trunks provide remote access to Norstar from the public network; E&M trunks provide remote access from a private network. Each must be configured to be auto-answer (in Trunk data programming) to provide remote system access.

A loop start trunk **must** have disconnect supervision if it is to operate in auto-answer mode. E&M trunks always operate in disconnect supervised mode.

When a caller dials into the system on a line that has auto-answer, the system answers with system dial tone and no Class of Service (COS) password is required. In this case, control over the system capabilities available to the caller is provided only by the dialing filters assigned to the line.

When a caller dials in on a line that has auto-answer with DISA, the system answers with stuttered dial tone. This is the prompt to enter a COS password which determines which system capabilities are available to the caller.

Remote access on a private network

Nodes on the private network deliver the last dialed digits to the destination Norstar node, for interpretation by the destination Norstar node. The destination Norstar node either matches the digits to a target line or interprets the digits as a remote feature request. The call is either routed to the specified target line, or the remote feature is activated.

By default, E&M trunks are set to answer with DISA. For auto-answer E&M trunks connected to a private network, change the default so that the trunks are **not** answered with DISA.

If an auto-answer E&M trunk is configured to answer with DISA, the system tries to interpret any received digits as a COS password.

The DISA DN and the Auto DN allow auto-answer private network and DID calls, in the same way that calls on auto-answer loop start and auto-answer E&M trunks can be answered, with or without DISA. These DNs are described in Configuration Programming under heading **6. Miscellaneous**.

Remote access on Direct Inward Dial (DID) trunks

Remote system access on DID trunks is similar to that of E&M trunks connected to a private network. The main differences are:

- a remote caller is on the public network dialing standard local or long-distance telephone numbers
- the digits received are delivered by the central office
- DISA cannot be administered to a DID trunk

As with a private network, the dialed digits may be programmed to match those of a specific target line DN, the DISA DN or the Auto DN.

Benefits

Security

In the Capabilities section of Administration programming, there are several ways of protecting your Norstar system from unauthorized access or use.

Class of Service

Class of Service refers to the capabilities that Norstar provides to users who access the system from the public or private network. The Class of Service includes:

- filters that restrict dialing on the line, and
- an access package, which defines the set of line pools that may be accessed and whether or not the user has access to the paging feature.

The Class of Service that is applied to an incoming remote access call is determined by:

- the filters that you apply to the incoming trunk, or by
- the Class of Service password that the caller used to gain access to the Norstar system.

In cases where DISA is not automatically applied to incoming calls, the remote caller can change the Class of Service by dialing the DISA DN and entering a Class of Service password.

To program Class of Service passwords, see the Programming chapter in the *System Coordinator Guide*.

Dialing filters

You can use dialing filters to restrict the numbers that may be dialed on any external line within your Norstar system. You may specify up to 100 dialing filters for the system. A dialing filter consists of up to 48 restrictions and their associated exceptions.

To restrict dialing within the system, you can apply dialing filters to outgoing external lines (as line filters), to telephones (as set filters), and to external lines on specific telephones (as line per set/filters).

Dialing filters can also be specified in Restrictions service for times when the system is operating according to a Service Mode. Refer to the description of Service Modes in the *System Coordinator Guide* for more details.

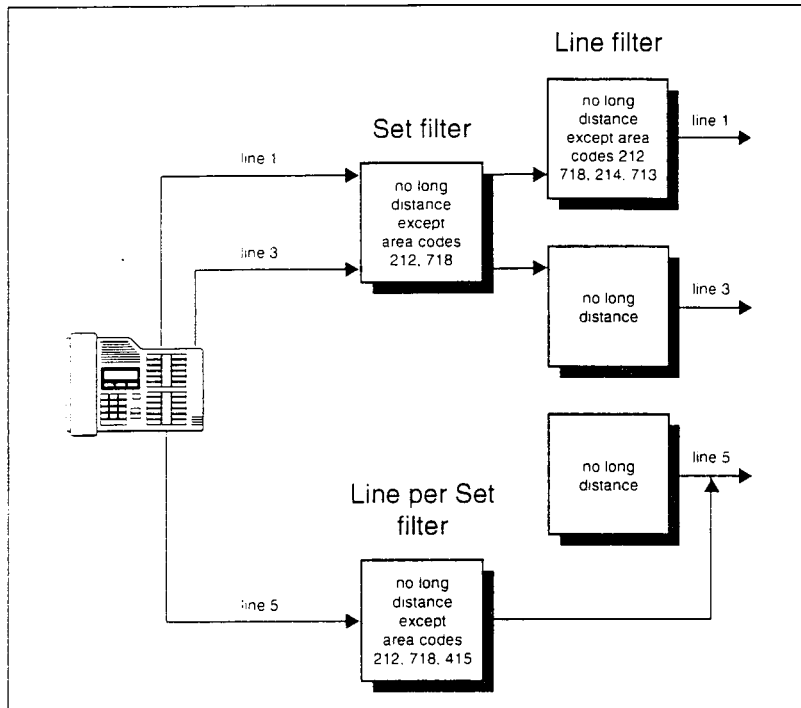

Dialed digits must pass both the line filter and the set filter. The line per set filter overrides the line filter and set filter.

In this diagram, a caller using line 1 could only dial long-distance numbers to area codes 212 and 718. A caller using line 3 could not dial any long-distance numbers. A caller using line 5 could dial long-distance numbers to area codes 212, 718, and 415.

Tips

Set filters have no effect on numbers dialed on an E&M trunk.

To restrict dialing outside the system (once a caller gains remote access), you can apply dialing filters to incoming external lines (as remote filters).

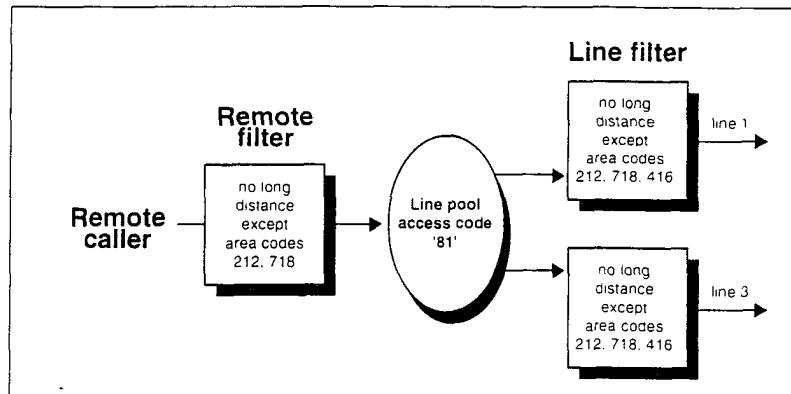

In this case, dialed digits must pass both the remote filter and the line filter. A remote caller can override these filters by dialing the DISA DN and entering a Class of Service password.

For dialing filter programming instructions, see the Programming chapter in the *System Coordinator Guide*.

Direct inward system access (DISA)

To control access from the public or private network, you can configure auto-answer trunks to answer with DISA. Remote callers hear a stuttered dial tone and must then enter a Class of Service password that determines what they are allowed to do in the system.

Auto-answer loop start and E&M trunks are configured to answer with DISA by default.

Tips

You must have one E&M/DISA Trunk Cartridge to provide DTMF receivers for every two auto-answer loop start trunks on Loop Start or CI Trunk Cartridges.

DID trunks cannot be configured to answer with DISA. If you want incoming DID calls to be answered with DISA, configure the system with a DISA DN. Incoming DID calls that map onto the DISA DN are then routed to a line that has DISA.

For DISA programming instructions, see the Programming chapter.

Transparent dialing plan

The Norstar system has a new routing feature that allows you to set up a transparent or coordinated dialing plan with other systems in the public or private network. Network transparency depends, to a large degree, on establishing a network-wide dialing plan where all DN numbers are unique and of a uniform length.

Using a transparent dialing plan, systems can distinguish between other systems on the network, and specific DNs on the various systems.

Example of a transparent dialing plan table

Systems in network	Range of DNs	Connected to node at	Connected by line pool	Pool code
Toronto	26221 to 26294	New York	G	72
New York	32295 to 32363	Dallas Manhattan	C D	70 71
Manhattan	34321 to 34498	New York Toronto	H G	73 72
Dallas	43221 to 43257	New York	H	73

Defining routes

Norstar allows you to create up to 200 routes for the routing of calls.

The first setting, Route number, assigns a unique number for a particular call routing. The second setting, Use pool, defines which line pool is to be used to reach that destination. The third setting, Dial out, specifies the digit string of up to 24 digits, to be dialled out (if any).

For example, the system in New York might have the following routes defined.

Route number (001 to 200)	Use line pool:	Dial out (max. 24 digits or characters)
001	Pool A	1-555-123-4567
022	Pool C	
023	Pool A	1-214-555-1234
104	Pool D	72

Route 001 is used to call a sales rep in another city. Route 022 is used to call the Dallas office using the system's E&M trunk. Route 023 is used to call the Dallas office on weekends when the rates on CO lines are lower. Route 104 is used to make a tandem call to the Toronto office using the E&M line on the system in Manhattan.

Destination codes

Once you have defined routes for the various destinations, the destination code table lets you assign a route for a specific destination to be used according to the Service Mode in effect.

Up to six Service Modes can be programmed according to hours of the day or days of the week, in addition to the normal mode. Refer to the description of Service Modes in the *System Coordinator Guide* for more details.

For example, the system in New York might have the following destination code defined to make calls to the system in Dallas.

Dest code	Route to use						
	Normal mode	Mode 1	Mode 2	Mode 3	Mode 4	Mode 5	Mode 6
63	022	-	-	-	023	-	-

During normal business hours, calls to Dallas use route 022, which uses the E&M trunk. On weekends, Routing service mode 4 is in effect. Calls to Dallas then use route 023 to take advantage of lower rates on CO lines.

Line pools

If the Norstar systems are close to each other geographically, you can conserve resources by not duplicating access. For example, system A, B, and C are all within the same area code. System A has a line pool to New York, System B has a line pool to Los Angeles, and system C has a line pool to Dallas. A Norstar user in system A can reach Dallas by calling system C and using their line pool to Dallas.

Line pool access codes

To simplify access between Norstar systems, all line pools that go to the same destination should have the same line pool access code. For example, system A and system B both have a line pool to Nashville. You can configure both systems with the same line pool access code for the Nashville line pool.

Transparent dialing plan among four systems

A dialing plan similar to the one in the following figure will let you create a company directory that uses line pool access codes and unique DNs of a uniform length.

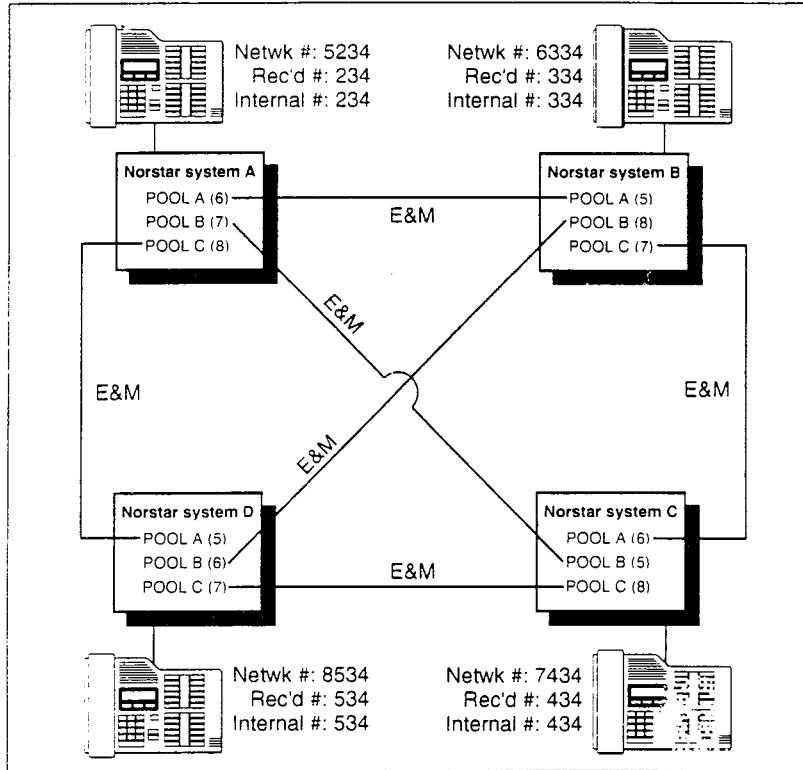

For instance, the person on system A at telephone 234 can press an Intercom button and dial 7434.

This means that telephone 234 has dialed the line pool access code of the trunk to system C, and will receive the dial tone of system C. The digits 434 then map to the Received number 434, and ring telephone 434 with an appearance of the associated target line.

Customer Use

This section shows sample configurations for different types of network access. Each example has four parts:

- A scenario explains the caller's goal and what is required to achieve it.
- A diagram shows the network configuration that supports the application.
- A list shows the Norstar hardware required to support the configuration.
- Tables show the Configuration and Administration programming required. Only those settings that are important to network access are described here.

In the public network

Call one or more Norstar telephones

Ms. Nelson is a bank customer who has a question for an accountant. She dials the telephone number that maps onto target line 203. All of the accountants' telephones ring.

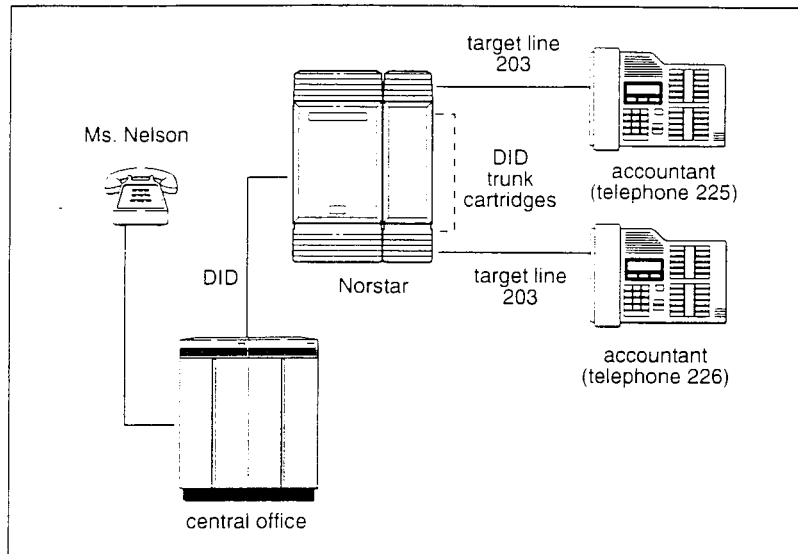

Hardware: KSU, a Trunk Module with a DID Trunk Cartridge, or a DTI with lines programmed as DID.

Heading	Parameter	Setting
1. Trk/Line Data	Rec'd #	4321 (for Line 203)
	Line 051	DID
6. System Data	Rec'd # length	4 (can be up to 7 digits, but must match number of digits sent by central office)

Call Norstar and select tie lines to a private network

A manager in Georgia wants to use the tie lines at headquarters to call Washington. He dials a telephone number that maps onto the DISA DN, enters a Class of Service (COS) password, then dials a line pool access code to select a tie line to Washington.

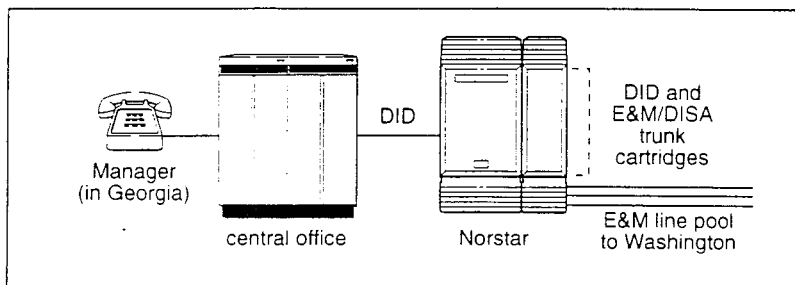

Hardware: KSU, a Trunk Module with a DID Trunk Cartridge, two E&M/DISA Trunk Cartridges (for the three trunks in the line pool to Washington) or a DTI with one DID line and three E&M lines.

Heading	Parameter	Setting
<i>Incoming trunk:</i>		
1. Trk/Line Data	Line 049	DID
5. Miscellaneous	DISA DN	5321
6. System Data	Rec'd # length	4 (can be up to 7 digits, but must match number of digits sent by central office)
<i>Outgoing trunk:</i>		
1. Trk/Line Data	Line 053 Line type	E&M Pool F
5. Miscellaneous	Line pool F	6 (up to 4 digits)
6. Capabilities		Define filters. Define remote access pkgs. Assign a dialing filter to the line. Assign COS passwords and filters for each class of service.

Call Norstar and select lines to the public network

Gord wants to make a long-distance business call from home. To avoid being charged, he dials the telephone number that maps onto the Auto DN at work. After hearing the dial tone, Gord dials a line pool access code to select a line to the public network. He then dials the long-distance number.

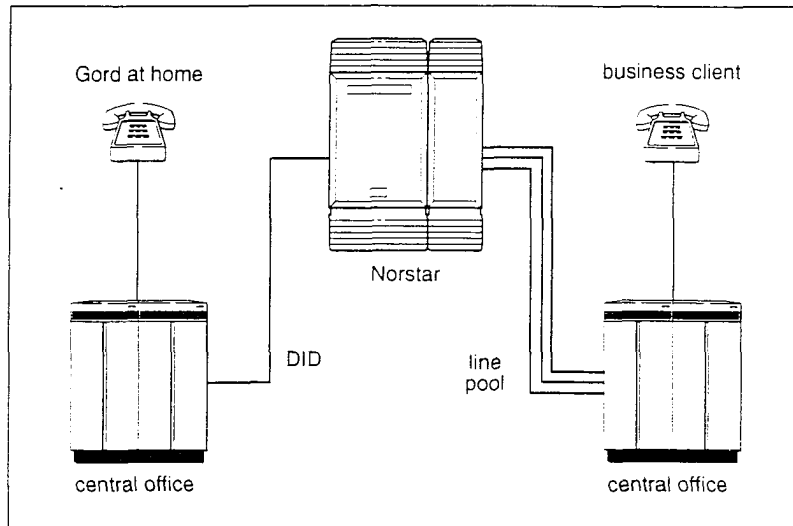

Hardware: KSU, a Trunk Module with a DID Trunk Cartridge or DTI with several DID lines.

Heading	Parameter	Setting
<i>Incoming trunk:</i>		
1. Trk/Line Data	Line 049	DID
5. Miscellaneous	Auto DN	4321
6. System Data	Rec'd # length	4 (can be up to 7 digits, but must match number of digits sent by central office)
B. General admin		Define dialing filters.
5. Capabilities		Define remote access packages. Assign a remote filter and remote package to the line.
<i>Outgoing trunk:</i>		
1. Trk/Line Data	Line 001	Loop
	Line type	Pool A
5. Miscellaneous	Line pool A	1234
B. General admin		Assign a dialing filter to the line.
5. Capabilities		

In the private network

Call one or more Norstar telephones

The production supervisor in Houston selects the less-expensive company tie line to call the manager at the Administration office in Dallas. Once the line is selected, the production supervisor dials the digits that will map onto the target line of the manager in Dallas.

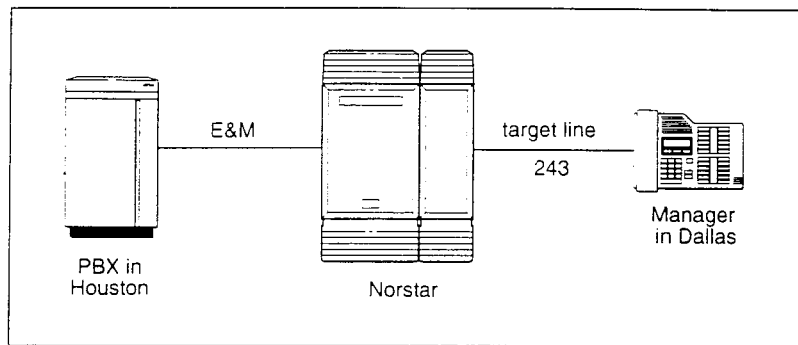

Hardware: KSU, a Trunk Module with an E&M/DISA Trunk Cartridge or a DTI with an E&M line.

Heading	Parameter	Setting
<i>Incoming trunk:</i>		
1. Trk/Line Data	Rec'd #	4321(for target line 243)
	Line 049	E&M
	Ans Mode	Auto
6. System Data	Rec'd # length	4 (can be up to 7 digits, but must match number of digits sent by central office)

Call Norstar and select tie lines to other nodes in the private network

At a branch office, Joan selects a tie line to the main office downtown. After hearing the dial tone, she dials a line pool access code to select another tie line to a branch office in the next state.

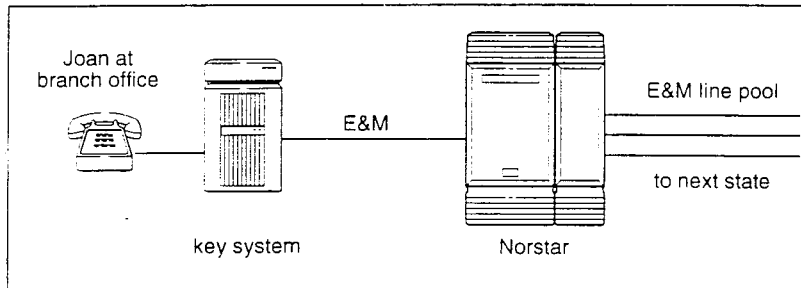

Hardware: KSU, a Trunk Module with two E&M/DISA Trunk Cartridges (for the three lines in the line pool and the one incoming line) or a DTI with four E&M lines.

Heading	Parameter	Setting
<i>incoming trunk:</i>		
1. Trk/Line Data	Line 049 Ans mode	E&M Auto
B. General admin 5. Capabilities		Define dialing filters. Define remote access packages. Assign a remote line filter and remote package to the trunk.
<i>Outgoing trunk:</i>		
1. Trk/Line Data	Line 050 Line type	E&M Pool D
5. Miscellaneous	Line pool D	71 (up to 4 digits)
B. General admin 5. Capabilities		Assign a dialing filter to the trunk.

Call Norstar and select lines to the public network

Liz in Memphis, needs to call long-distance to a client in Toronto. She selects a tie-line to the branch office in Toronto. After hearing the dial tone, she dials a line pool access code to select a line to the public network. Then, she dials the client's number as a local call.

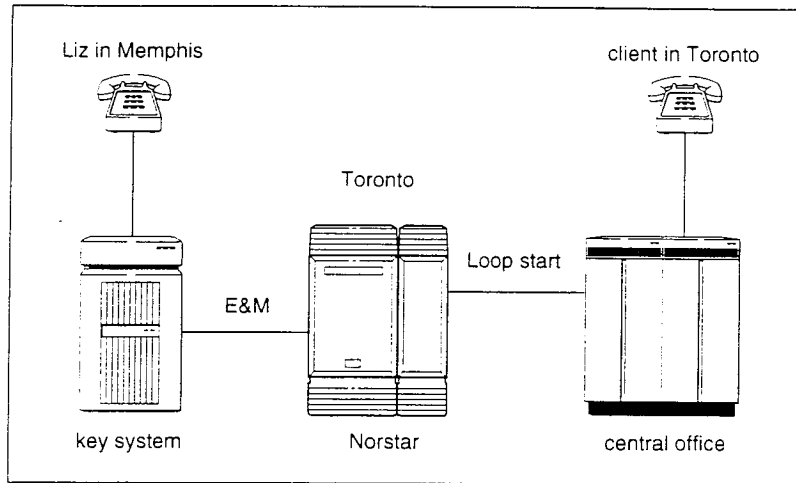

Hardware: KSU, a Trunk Module with an E&M/DISA Trunk Cartridge or DTI with an E&M line.

Heading	Parameter	Setting
<i>Incoming trunk:</i>		
1. Trk/Line Data	Line 049 Ans mode	E&M Auto
B. General admin 5. Capabilities		Define dialing filters and remote access packages. Assign a remote filter and remote package to the trunk.
<i>Outgoing trunk:</i>		
1. Trk/Line Data	Line 001 Line type	Loop Pool B
5. Miscellaneous	Line pool B	73 (up to 4 digits)
B. General admin 5. Capabilities		Assign a dialing filter to the line.

In the Norstar system

Select E&M trunks to the private network

For a confidential call, the Montana sales manager presses the line button for a private E&M trunk to the Oregon office. This automatically alerts at the line appearance on the telephone of the Oregon sales manager.

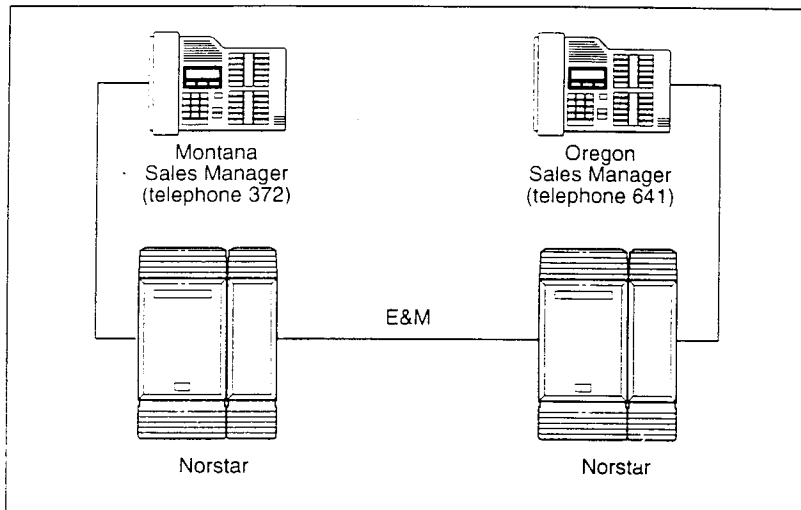

Hardware: (for both systems) KSU, a Trunk Module with an E&M/DISA Trunk Cartridge or a DTI with an E&M line.

Heading	Parameter	Setting
Montana:		
<i>Outgoing trunk:</i>		
Trunk Data (Line 049)	Line	E&M
Line Data (Line 049)	Line type	Private to 372
Oregon:		
<i>Incoming trunk:</i>		
Trunk Data (Line 057)	Line	E&M
	Ans mode	Manual
	Line type	Private to 641

Use the routing table to reach a far node in the private network

With a transparent dialing plan and routing table, Christopher in Manhattan can call his colleague Katherine in Dallas as simply as calling someone in the next office.

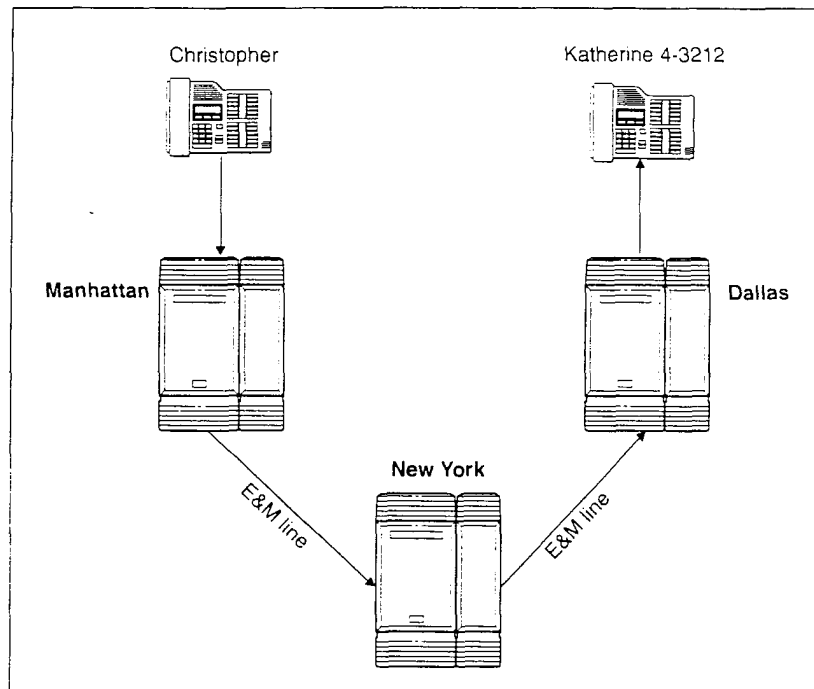

Hardware: The systems in Manhattan and New York must each be a Norstar 0X32 Release 1 - T1 system. The system in Dallas must be a Norstar system equipped with target lines. The Norstar systems must have a Trunk Module with a E&M/DISA Trunk Cartridge or a KSU with a DTI with at least one E&M line.

Heading	Parameter	Setting
Manhattan:		
1. Trk/Line Data	Line 024	E&M
	Line type	Pool H
3. Routing	DestCode	43
	Use route	007
	Route 007 Use	Pool H
	DialOut	63
New York:		
<i>Incoming line:</i>		
1. Trk/Line Data	Line 024	E&M
	Answer mode	Auto
	Dial mode	Tone
<i>Outgoing line:</i>		
1. Trk/Line Data	Line 120	E&M
	Line type	Pool C
3. Routing	DestCode	63
	Use route	022
	Route 022 Use	Pool C
	DialOut	None
Dallas:		
1. Trk/Line Data	Line 120	E&M
	Answer mode	Auto
	Dial mode	Tone
	Line 245	Target line
	Received #	212

With this configuration, when Christopher dials 4-3212, the system recognizes 43 as a destination code. Destination code 43 is programmed to use route 007 which is programmed to use a line in pool H and dial the digits 63. So the system seizes the E&M trunk in line pool H and dials 63. This connects Christopher to the Norstar system in New York.

The Norstar system in New York recognizes 63 as a destination code. On this system, destination code 63 is programmed to use route 022, which is programmed to use a line in pool C. The system in New York then seizes the E&M trunk in line pool C and connects

Christopher to the system in Dallas. Since the E&M trunk is programmed to be auto answered in Dallas, no dial out digits are necessary.

The system in Dallas receives the remainder of the digits Christopher dialed (212) and routes the call to target line 245 which is assigned to Katherine.

Norstar Line Redirection feature

The branch office is receiving more calls than it can handle, so it redirects one of its lines to the main office. All calls that come in on target line 232 will be routed out on line 003 to the main office. Whenever a call is redirected, the target line and outgoing line will be busy for the duration of the call.

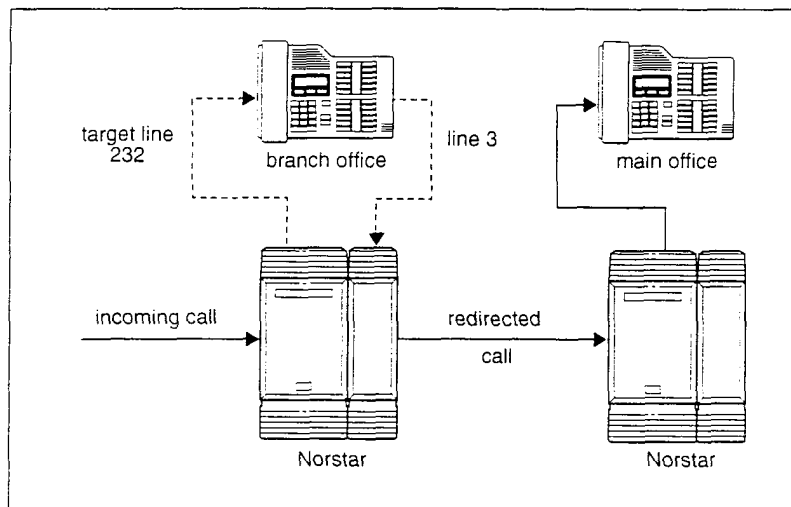

Hardware: KSU, an E&M/DISA Trunk Cartridge if the incoming trunk is E&M or a DID Trunk Cartridge if the incoming trunk is DID, or a DTI with one E&M line or one DID line.

Tips

Any line appearance on a telephone can be selected as the incoming line to be redirected. A target line can not be selected as the outgoing line for redirection.

The incoming trunk must have disconnect supervision.

Planning the installation

Planning checklist

- Verify that you have all the equipment and supplies you need to install the system.
- Determine the location for the Key Service Unit (KSU) and expansion modules, telephones and other equipment.
- Select the default template to be used in System Startup programming. See the Programming chapter.
- Plan and record system programming details in the *Programming Record*.

Required equipment and supplies

- Key Service Unit (KSU)
- Feature Cartridge
- Trunk Cartridge(s) for the KSU
- Services Cartridge (one required with Digital Trunk Interfaces)
- Emergency telephone (2 for KSU, 1 for each TM)
- Norstar telephones
- Distribution panel(s)

Expansion equipment

- Expansion Cartridge (either a two-port or six-port)
- Trunk Module(s) (TM)
- Station Module(s) (SM)
- Trunk Cartridge(s) for the TM
- Power bar

The Key Service Unit (KSU) supports up to 32 telephones. With the addition of Trunk Cartridges, you can connect up to 48 lines to the KSU.

With the addition of an Expansion Cartridge in the KSU, you can add Trunk Modules and/or Station Modules to increase your system capacity. With the 2-port Expansion Cartridge you can connect up to two Trunk Modules and/or Station Modules; with the 6-port Expansion Cartridge you can connect up to six Trunk Modules and/or Station Modules in any combination.

If you plan to configure lines on a Loop Start Trunk Cartridge as auto-answer, you will need an E&M Trunk Cartridge for every two auto-answer loop start lines. The E&M Trunk Cartridge provides DTMF receivers for auto-answer loop start lines.

You can install three additional Trunk Cartridges in each Trunk Module. The following table shows you the line capacity of each Trunk Cartridge.

Trunk Cartridge	Line capacity
DTI (KSU only)	24
Loop Start with disconnect supervision	4
CI	4
DID (TM only)	4
E&M (TM only)	2

You can install different types of Trunk Cartridges together in the same Trunk Module. When mixing Trunk Cartridges, use a separate block on the distribution panel for each type of Trunk Cartridge.

Each Station Module allows you to connect up to 16 additional Norstar telephones to the system.

KSU	SM1	SM2	SM3	SM4	SM5	SM6
32	48	64	80	96	112	128

Optional equipment

- station auxiliary power supply (SAPS)
- Busy Lamp Field (BLF)
- central answering position (CAP) module
- Analog Terminal Adapter (ATA)
- uninterruptible power supply
- other

If the system will be equipped with T1 lines, use an uninterruptible power supply so that the T1 - keep alive signal will continue to be sent to the network in the event of a power failure.

Equipment for installing the KSU and expansion modules

- screwdriver
- pliers
- connecting tool
- four 19 mm (3/4 in) wood screws for each of the mounting brackets
- 38 mm (1 1/2 in) screws for the cable troughs (KSU - 2, TM - 4, SM - 2)
- 19 mm (3/4 in) wood backboard (if necessary)

Location requirements

- clean, dry, and well-ventilated
- temperature between 0 and 50°C (32 and 122°F)
- humidity between 5 and 95%, non-condensing
- minimum distance of 4 m (13 ft) from equipment such as photocopiers, electrical motors and other equipment that can produce electromagnetic, radio-frequency, and electrostatic interference

Electrical requirements

- non-switched outlet within reach of the KSU and modules

The KSU and module power cords are 1.5 m (5 ft) long. You may connect the KSU and modules to a power bar. The power bar must be CSA certified and UL listed with a third ground wire. Do not use an extension cord between the KSU and the power bar, or between the power bar and the electrical outlet.

- ac outlet equipped with a third wire ground to avoid electromagnetic interference
- dedicated 110 V ac nominal, 50/60 Hz, 15 A minimum service with a third wire ground

	Check ground connections
	Ensure that the electrical ground connections of the power utility, telephone lines and internal metallic water pipe system, if present, are connected together. If they are not connected together, contact the appropriate electrical inspection authority. Do not attempt to make the connections yourself.

Internal wiring requirements

- one twisted pair per telephone
- dc loop resistance of less than 64 Ω
- cable length (0.5 mm or 24 AWG) less than 300 m (1000 ft)
- use of a station auxiliary power supply (SAPS) for loops 300 m (1000 ft) to 790 m (2600 ft). The SAPS must be a Class 2 power source that is UL and CSA listed.
- no bridge taps

	Verify lightning protectors
	Check the lightning protectors at the cable entry point to the building with special attention to the grounding. Report any problems to the telephone company in writing. Norstar telephone wiring is not lightning protected and should therefore not leave the building.

Spacing requirements

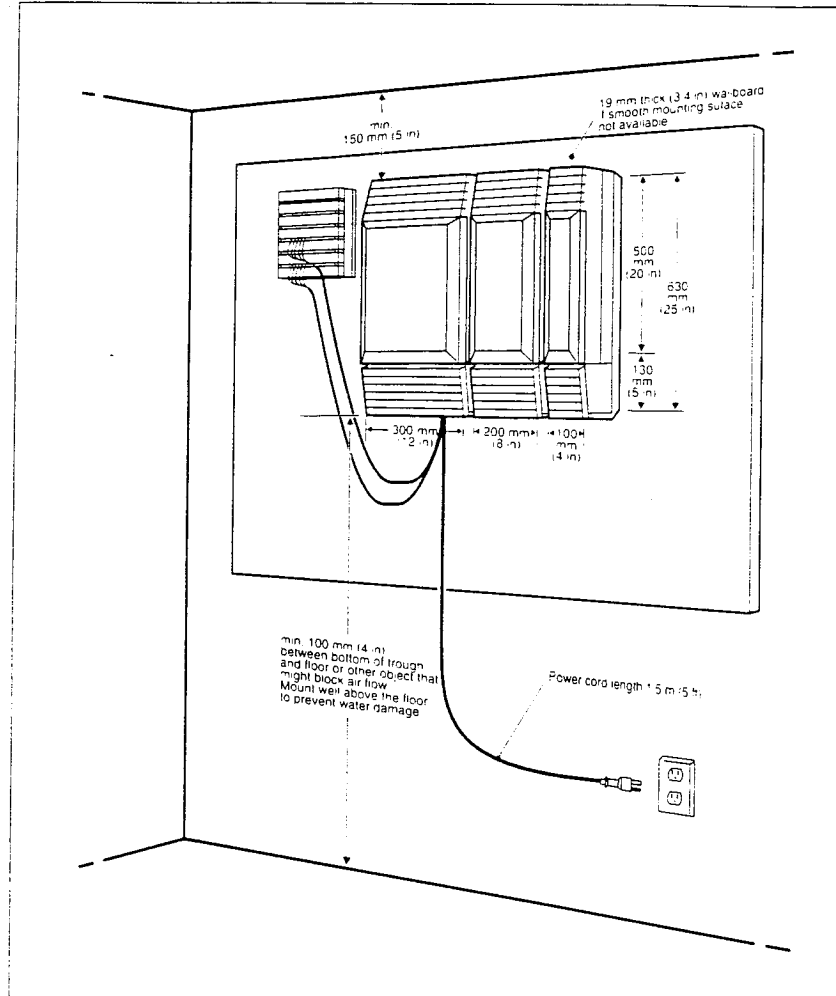

Installation

	<p style="text-align: center;">Avoid electrical shock</p> <p>To avoid electrical shock hazard to personnel, or equipment damage, observe the following precautions when installing telephone equipment:</p> <p>Never install telephone wiring during a lightning storm.</p> <p>Never install telephone jacks in wet locations unless the jack is specifically designed for wet locations.</p> <p>Never touch non-insulated telephone wires or terminals unless the telephone line has been disconnected at the network interface.</p>
---	--

Installation checklist

- mount the Key Service Unit (KSU) and expansion modules (as required)
- install the Feature Cartridge
- install the Expansion Cartridge and Trunk Cartridges (as required)
- connect the expansion modules
- complete the wiring
- install the emergency telephone(s)
- install the Norstar telephones
- install the single-line telephones
- install the optional equipment
- power up the system

	<p style="text-align: center;">Attach brackets to secure surface</p> <p>Screw the KSU and module mounting brackets to a secure surface. Do not screw brackets to drywall.</p>
---	--

Installing the cartridges

The following table shows you which cartridges can be installed in which KSU and TM slots.

Cartridge type	Part number	Slot
Feature Cartridge	A0404146 NT7B72FA-93	A
Services Cartridge	A0404139 NTBB24GA-93	B
Fiber Expansion Cartridge (2-port)	A0404244 NTBB02GA-93	C
Fiber Expansion Cartridge (6-port)	A0404245 NTBB06GA-93	C
Digital Trunk Interface (DTI)	A0404135 NT7B74GA-93	D
Loop Start Trunk Cartridge	A0405799 NT7B75GA-93	D,E
CI Trunk Cartridge	A0393277 NT5B41GA-93	D,E
E&M Trunk Cartridge	A0359618 NT5B38GA-93	E
DID Trunk Cartridge	A0359617 NT5B37GA-93	E

The DTI supports digital T1 lines. The Loop Start Trunk Cartridge supports loop start external lines. The CI Trunk Cartridge supports Call Display features on loop start external lines. The E&M Trunk Cartridge supports E&M lines and provides direct inward system access (DISA). The DID Trunk Cartridge supports direct inward dialing lines.

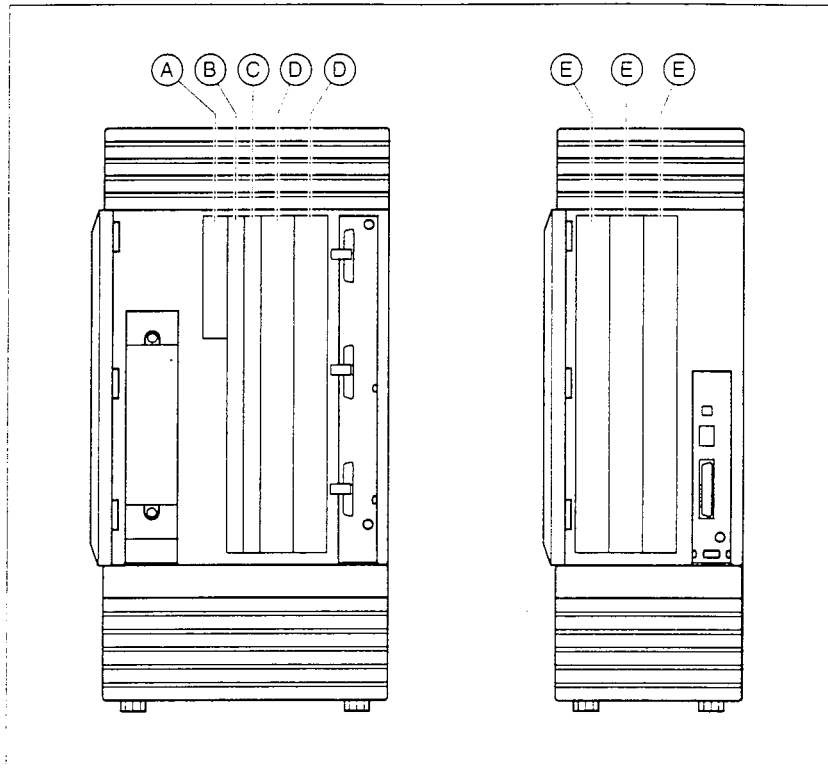

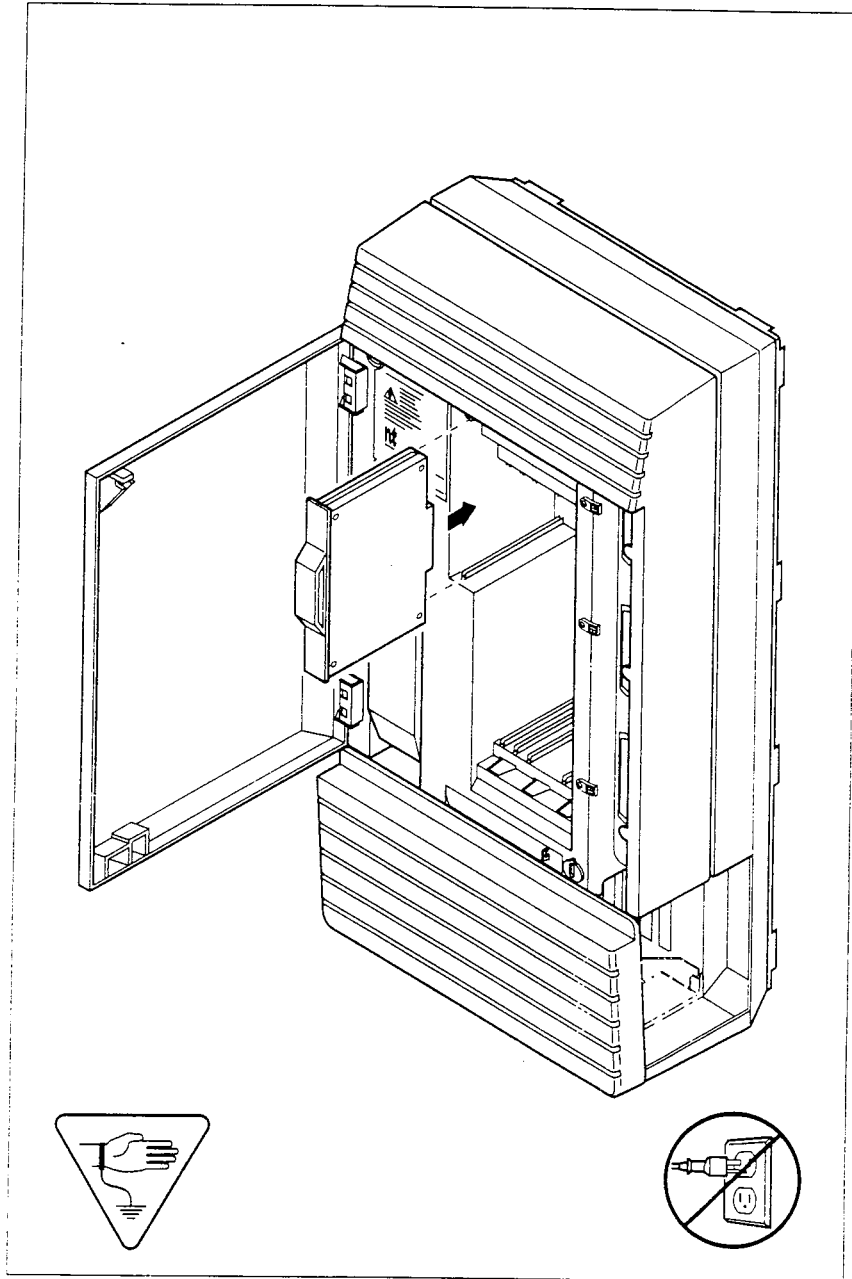

	<p style="text-align: center;">Avoid risk of electrical shock</p> <p>Voltages of up to 130 V may be present on the 1.544 Mbps circuit and on portions of the DTI circuitry.</p>
---	--

Installing the Feature Cartridge

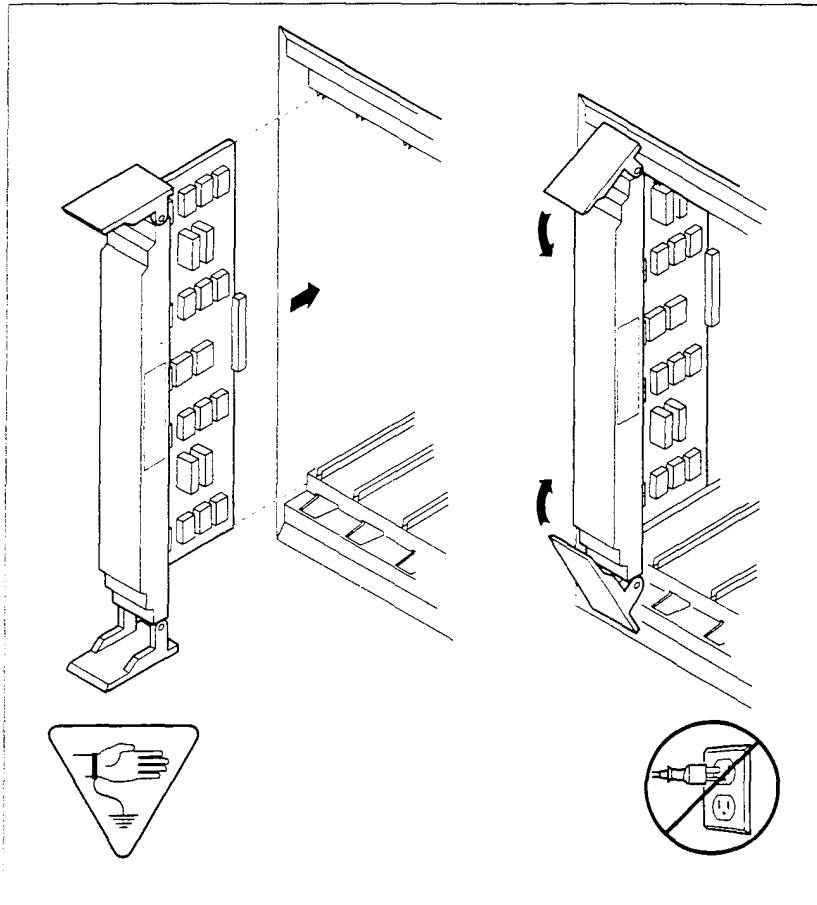

Installing cartridges



	<p>Close clips simultaneously</p> <p>It is important to center and close the two clips on the cartridge simultaneously, or the cartridge may become misaligned in its slot, or with its connector.</p>
---	---

	<p style="text-align: center;">PCB is electrostatic-sensitive</p> <p>Do not touch the printed circuit board on a cartridge. This is an electrostatic-sensitive device.</p>
---	---

Tips

Install Trunk Cartridges in the KSU beginning with the right-most slot, and work left. Install Trunk Cartridges in a Trunk Module (TM) beginning with the left-most slot and work right.

For easier wiring, install similar type Trunk Cartridges together in the same Trunk Module.

If you install an E&M or a DID Trunk Cartridge in the left-most slot (slot 1) of a TM, emergency telephones cannot be supported for that Trunk Module.

Connecting expansion modules

If your system includes fiber Trunk Modules and/or fiber Station Modules, you need to connect the modules to the Expansion Cartridge by means of fiber cables.

Order of expansion module connection

In order to keep the default port and extension numbering, connect Trunk Modules to the Expansion Cartridge beginning at the top and working down; connect Station Modules to the Expansion Cartridge beginning at the bottom and working up.

Two-port Expansion Cartridge

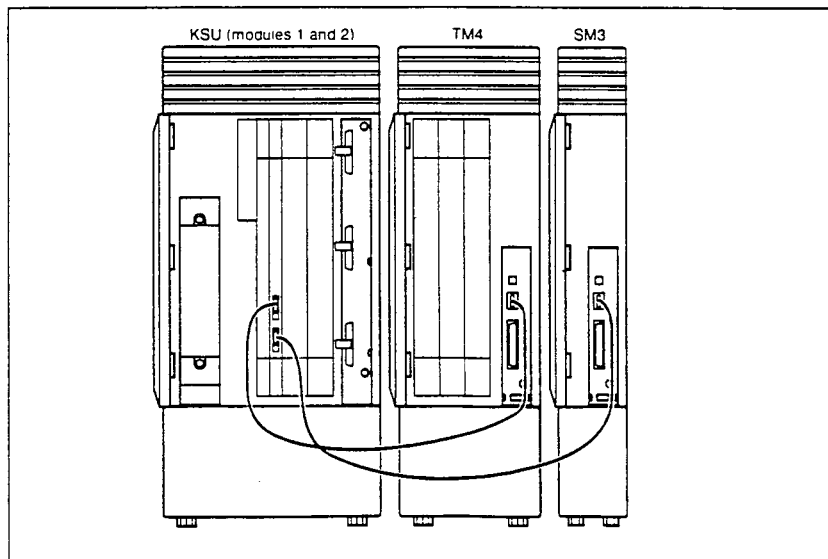

Six-port Expansion Cartridge

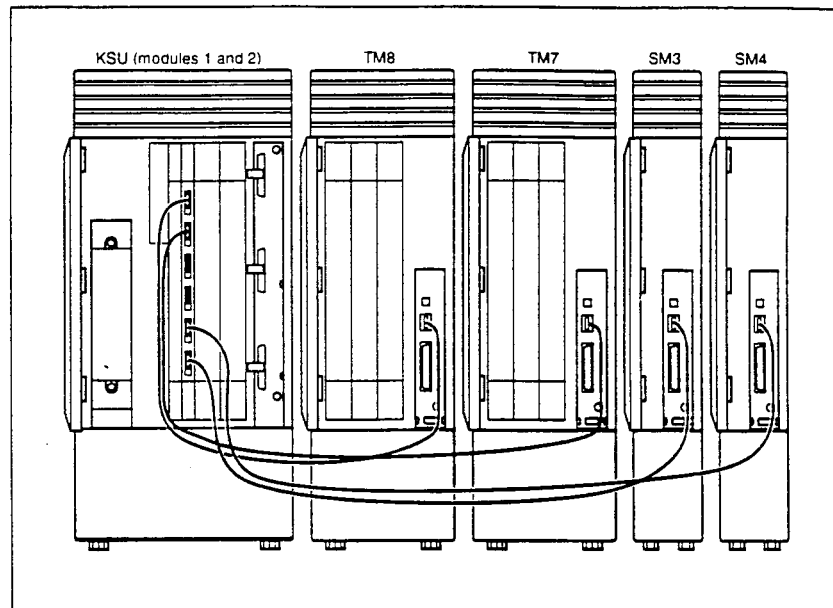

Installing fiber cables

Fiber cables are durable, but can be damaged. To avoid damage that can affect the signals transmitted, observe the following guidelines:

- Coil excess fiber cable on the spool provided for the installation.
- Secure the fiber cable spool in the KSU cable trough.
- Ensure that bends in the cable are no tighter than 100 mm (4 in) in diameter.
- When using cable ties, bundle fiber cables loosely.
- Avoid excessive pulling, compression or impact.
- Do not grasp the fiber cable, or the clasp where the cable joins the plug, when connecting or disconnecting a fiber cable plug into a port.
- Do not leave fiber cables in an environment with excessively high temperatures (for example, on top of radiators).

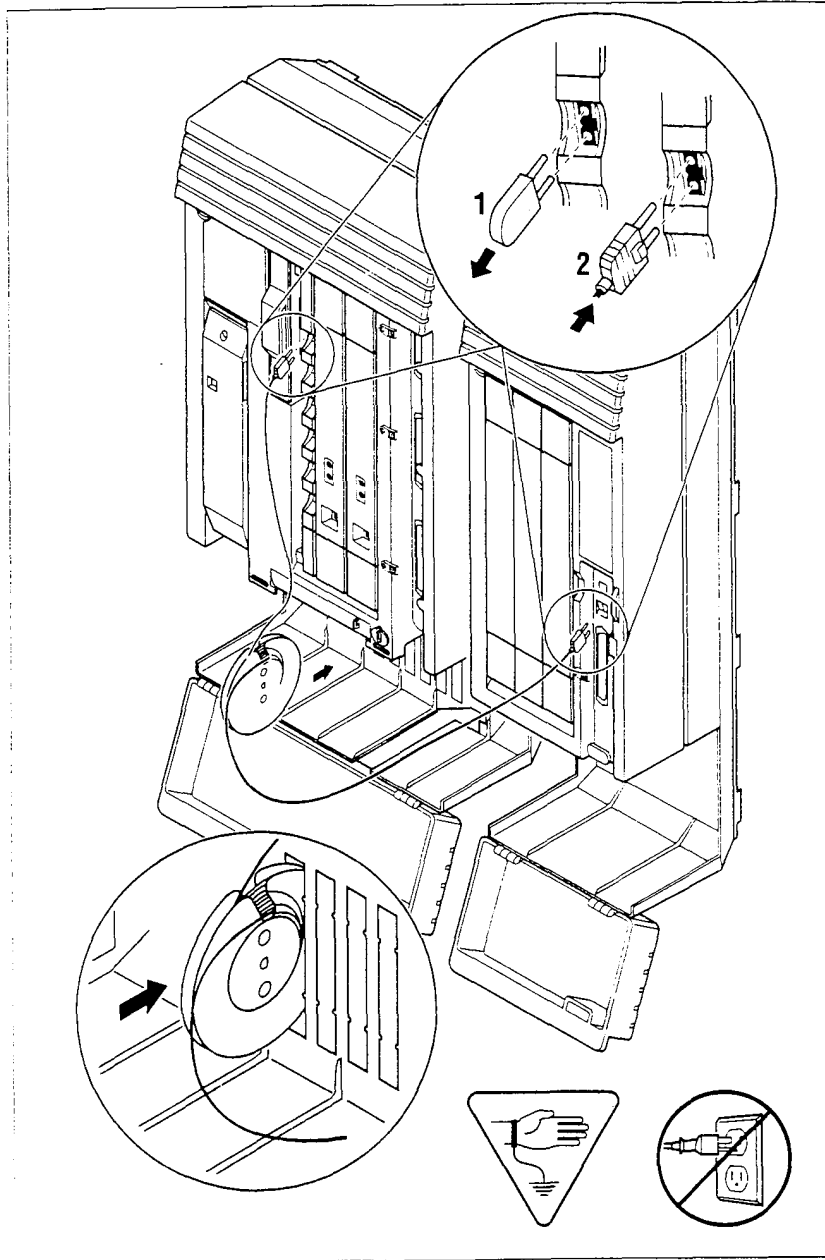

Connecting the wiring

Connecting the wiring for a KSU with loop start lines

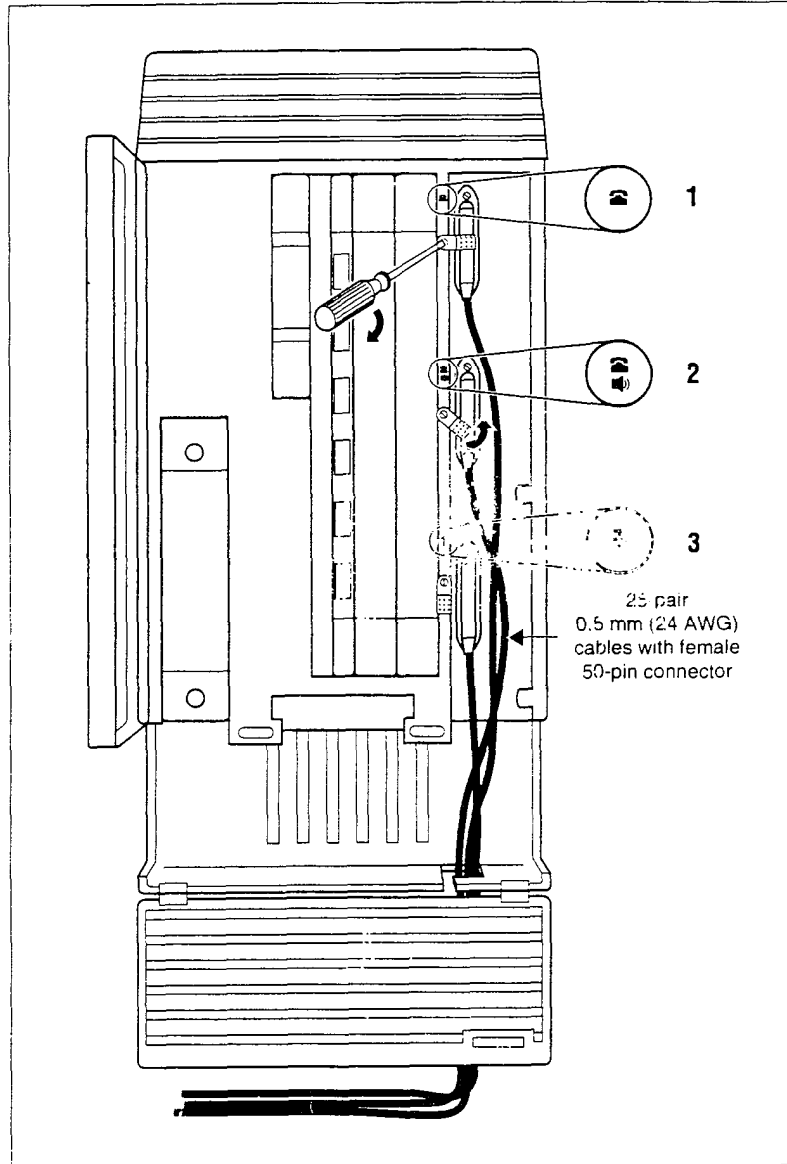

Connecting the wiring for a KSU with T1 lines

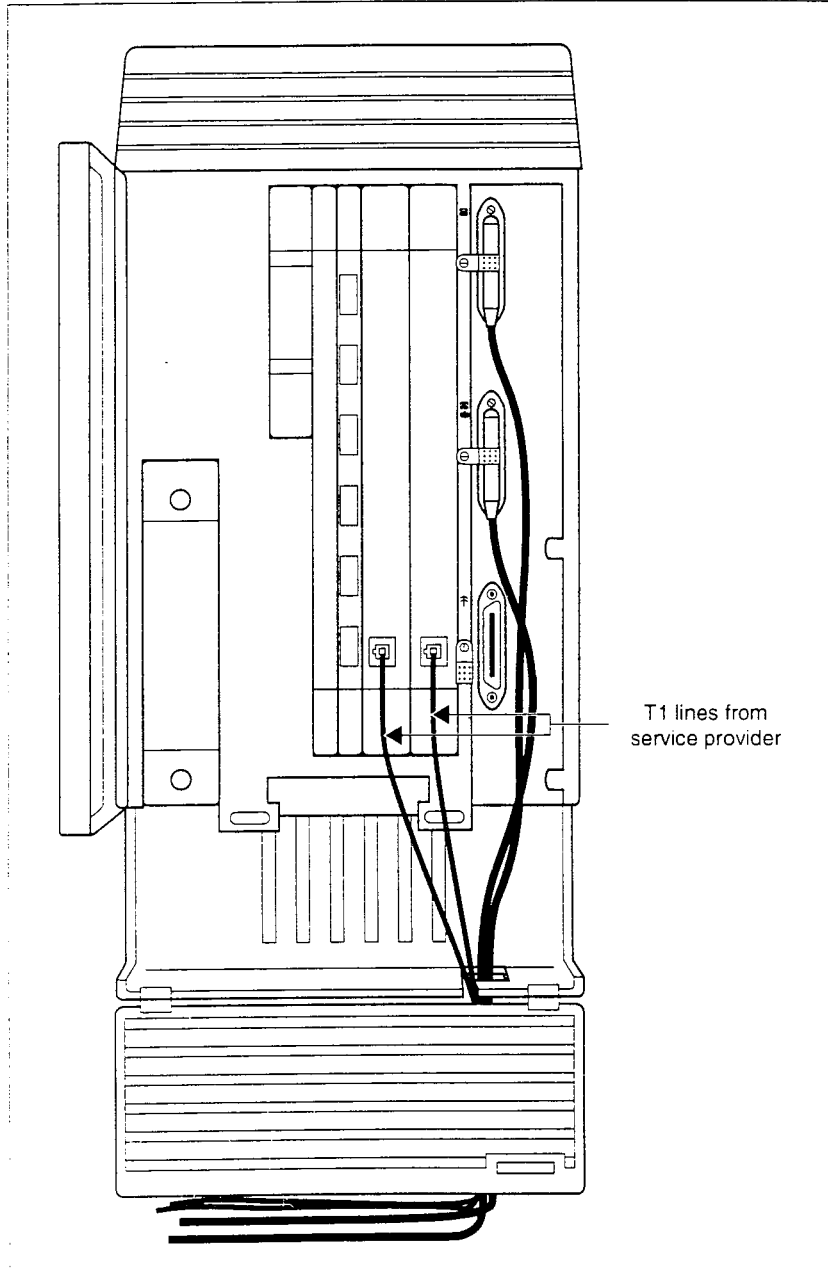

Connecting the wiring from a Trunk Module and Station Module

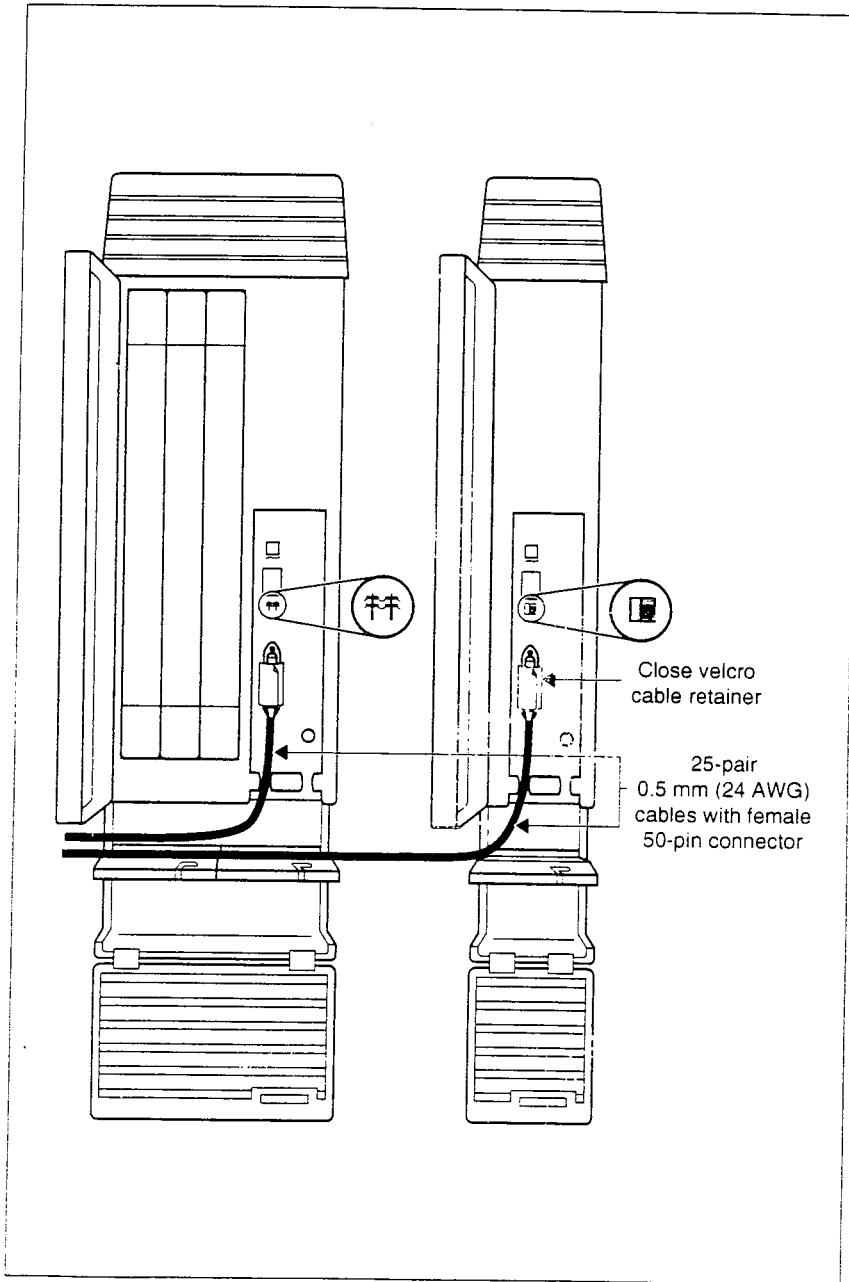

Connecting the wiring to the distribution panel

1. Route the cables through the hole in the KSU cable trough to the distribution panel.
2. Bundle the cables with cable ties and secure them to the wall to support their weight.
3. Connect the telephone and auxiliary equipment wires to the appropriate pins on the distribution block (refer to the wiring charts).
4. Cross-connect the KSU telephone and auxiliary equipment wiring and the Station Module telephone wiring to the corresponding station pins on the distribution block.
5. Using a single pair of wires for each telephone, connect each of the telephones according to the wiring charts.
6. Cross-connect the external lines (loop start, E&M, DID) to the distribution block (refer to the wiring charts).
7. The DTI is equipped with an internal channel service unit (CSU). You can connect the DTI directly to the termination point provided by your T1 service provider. If you disable the internal CSU, you can connect the DTI to an external CSU or multiplexer.

The DTI does not provide the DC connection required for through-fed repeaters. If through-fed repeaters are used on the T1 span, disable the internal CSU and connect the DTI to an external CSU.

Wiring charts

Port numbering on the wiring charts

The port number listed on the wiring charts is useful in tracking down faults during a Maintenance session where error codes appear on a Norstar telephone display (see the Maintenance chapter).

The port numbers (for example: "X12") on the Trunk Cartridge and Station Module wiring charts have two components:

- "X" corresponds to the number that appears on the face of the Expansion Cartridge port that the Trunk Module or Station Module is connected to.

- digits (for example "01" or "12") identify an individual port number associated with that Expansion Cartridge.

For example:

The code "812" appearing as part of an error message for a Trunk Module indicates that the problem is with Expansion Cartridge port #8 and internal port "12". The corresponding Trunk Module pins on the distribution block are pin 47 (violet-orange) and pin 22 (orange-violet).

Key Service Unit (KSU)

In the charts on the following pages, notice that the KSU has two internal modules, KSU #1 and KSU #2. KSU #1 handles telephones and auxiliary equipment. KSU #2 handles lines.

B1 and B2 directory numbers

The terms B1 and B2 correspond to channels on Norstar for transmitting voice and data. Each DN port number has a B1 DN and a B2 DN. Devices such as the Norstar M7100, M7208, M7310, and M7324 telephones use only the B1 DN. Other devices may need both B1 and B2 channels, therefore requiring B1 and B2 DNs.

Non-expanded system (KSU alone) numbering

Module #	Lines	Line ports	B1 DN	B2 DN	DN ports
KSU (#2)	001 - 048	201-248	---	---	---
KSU (#1)	---	---	21-52	53-84	101-132

Two-port Expansion Cartridge and KSU numbering

Expansion module #	Lines	Line ports	B1 DN	B2 DN	DN ports
#4	049-060	401-412	269-284	333-348	401-416
#3	061-072	301-312	253-268	317-332	301-316
KSU (#2)	001 - 048	201-248	---	---	---
KSU (#1)	---	---	221-252	285-316	101-132

Six-port Expansion Cartridge and KSU numbering

Expansion module #	Lines	Line ports	B1 DN	B2 DN	DN ports
#8	049-060	801-812	333-348	461-476	801-816
#7	061-072	701-712	317-332	445-460	701-716
#6	073-084	601-612	301-316	429-444	601-616
#5	085-096	501-512	285-300	413-428	501-516
#4	097-108	401-412	269-284	397-412	401-416
#3	109-120	301-312	253-268	381-396	301-316
KSU (#2)	001-048	201-248	---	---	---
KSU (#1)	---	---	221-252	349-380	101-132

Tips

Port #3 is the bottom fiber cable port on both the two-port and the six-port Expansion Cartridge.

B1 and B2 directory numbers reflect the default numbering scheme.

If you expand your system after initial installation and programming, there may appear to be gaps in your B1 DN numbering. This is because the system has already assigned DN numbers to B2 channels. You can correct these gaps by performing Startup programming and resetting the system memory, or by changing the individual DNs in **6. System Data** in Configuration programming.

Wiring arrangement for Norstar KSU

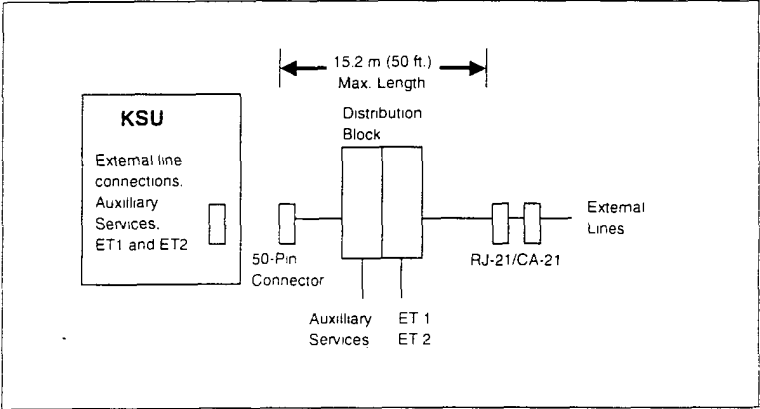

Wiring arrangement for Norstar TM

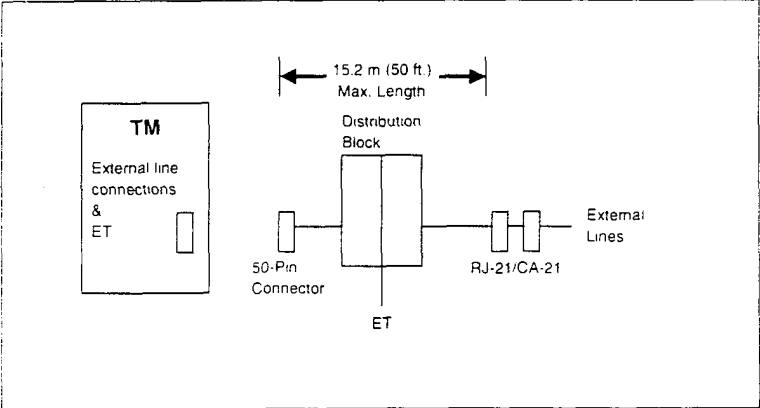

KSU telephone wiring chart

Pin	Wire color	Port	Service	Telephones (KSU)	Default DN
26	White-Blue	101	T	1	
1	Blue-White	101	R	1	21/221/2221
27	White-Orange	102	T	2	
2	Orange-White	102	R	2	22/222/2222
28	White-Green	103	T	3	
3	Green-White	103	R	3	23/223/2223
29	White-Brown	104	T	4	
4	Brown-White	104	R	4	24/224/2224
30	White-Slate	105	T	5	
5	Slate-White	105	R	5	25/225/2225
31	Red-Blue	106	T	6	
6	Blue-Red	106	R	6	26/226/2226
32	Red-Orange	107	T	7	
7	Orange-Red	107	R	7	27/227/2227
33	Red-Green	108	T	8	
8	Green-Red	108	R	8	28/228/2228
34	Red-Brown	109	T	9	
9	Brown-Red	109	R	9	29/229/2229
35	Red-Slate	110	T	10	
10	Slate-Red	110	R	10	30/230/2230
36	Black-Blue	111	T	11	
11	Blue-Black	111	R	11	31/231/2231
37	Black-Orange	112	T	12	
12	Orange-Black	112	R	12	32/232/2232
38	Black-Green	113	T	13	
13	Green-Black	113	R	13	33/233/2233
39	Black-Brown	114	T	14	
14	Brown-Black	114	R	14	34/234/2234
40	Black-Slate	115	T	15	
15	Slate-Black	115	R	15	35/235/2235
41	Yellow-Blue	116	T	16	
16	Blue-Yellow	116	R	16	36/236/2236
42	Yellow-Orange	117	T	17	
17	Orange-Yellow	117	R	17	37/237/2237
43	Yellow-Green	118	T	18	
18	Green-Yellow	118	R	18	38/238/2238
44	Yellow-Brown	119	T	19	
19	Brown-Yellow	119	R	19	39/239/2239
45	Yellow-Slate	120	T	20	
20	Slate-Yellow	120	R	20	40/240/2240
46	Violet-Blue	121	T	21	
21	Blue-Violet	121	R	21	41/241/2241
47	Violet-Orange	122	T	22	
22	Orange-Violet	122	R	22	42/242/2242
48	Violet-Green	123	T	23	
23	Green-Violet	123	R	23	43/243/2243
49	Violet-Brown	124	T	24	
24	Brown-Violet	124	R	24	44/244/2244
50	Violet-Slate	----	----	no connection	----
25	Slate-Violet	----	----	no connection	----

T and R represent station connections and should not be confused with Tip and Ring on external lines. Station connections are non-polarized.

KSU telephone and auxiliary equipment wiring chart

Pin	Wire color	Port	Service	Telephones (KSU)	Default DN
26	White-Blue	125	T	25	
1	Blue-White	125	R	25	45/245 2245
27	White-Orange	126	T	26	
2	Orange-White	126	R	26	46/246 2246
28	White-Green	127	T	27	
3	Green-White	127	R	27	47/247 2247
29	White-Brown	128	T	28	
4	Brown-White	128	R	28	48/248 2248
30	White-Slate	129	T	29	
5	Slate-White	129	R	29	49/249 2249
31	Red-Blue	130	T	30	
6	Blue-Red	130	R	30	50/250 2250
32	Red-Orange	131	T	31	
7	Orange-Red	131	R	31	51/251 2251
33	Red-Green	132	T	32	
8	Green-Red	132	R	32	52/252 2252
34	Red-Brown	----	----	no connection	
9	Brown-Red	----	----	no connection	
35	Red-Slate	----	----	no connection	
10	Slate-Red	----	----	no connection	
36	Black-Blue	----	----	no connection	
11	Blue-Black	----	----	no connection	
37	Black-Orange	----	----	no connection	
12	Orange-Black	----	----	no connection	
38	Black-Green	----	----	no connection	
13	Green-Black	----	----	no connection	
39	Black-Brown	----	----	no connection	
14	Brown-Black	----	----	no connection	
40	Black-Slate	----	T	Page	
15	Slate-Black	----	R	Page	
41	Yellow-Blue	----	Make	External page	
16	Blue-Yellow	----	Common	External page	
42	Yellow-Orange	----	T	Music	
17	Orange-Yellow	----	R	Music	
43	Yellow-Green	----	----	reserved	
18	Green-Yellow	----	----	reserved	
44	Yellow-Brown	----	Make	Auxiliary ringer - 1	
19	Brown-Yellow	----	Common	Auxiliary ringer - 1	
45	Yellow-Slate	----	----	reserved	
20	Slate-Yellow	----	----	reserved	
46	Violet-Blue	----	----	no connection	
21	Blue-Violet	----	----	no connection	
47	Violet-Orange	----	----	reserved	
22	Orange-Violet	----	----	reserved	
48	Violet-Green	----	----	reserved	
23	Green-Violet	----	----	reserved	
49	Violet-Brown	----	----	reserved	
24	Brown-Violet	----	----	reserved	
50	Violet-Slate	----	----	reserved	
25	Slate-Violet	----	----	reserved	

T and R represent station connections and should not be confused with Tip and Ring on external lines. Station connections are non-polarized.

KSU external loop start lines wiring

KSU external lines connector					RJ-21 external line connector	
Pin	Wire color	Port	Service	Line	Pin	Wire color
26	White-Blue	201	T	1	26	White-Blue
1	Blue-White	201	R	1	1	Blue-White
27	White-Orange	202	T	2	27	White-Orange
2	Orange-White	202	R	2	2	Orange-White
28	White-Green
3	Green-White
29	White-Brown
4	Brown-White
30	White-Slate	203	T	3	28	White-Green
5	Slate-White	203	R	3	3	Green-White
31	Red-Blue	204	T	4	29	White-Brown
6	Blue-Red	204	R	4	4	Brown-White
32	Red-Orange
7	Orange-Red
33	Red-Green
8	Green-Red
34	Red-Brown	205	T	25	30	White-Slate
9	Brown-Red	205	R	25	5	Slate-White
35	Red-Slate	206	T	26	31	Red-Blue
10	Slate-Red	206	R	26	6	Blue-Red
36	Black-Blue
11	Blue-Black
37	Black-Orange
12	Orange-Black
38	Black-Green	207	T	27	32	Red-Orange
13	Green-Black	207	R	27	7	Orange-Red
39	Black-Brown	208	T	28	33	Red-Green
14	Brown-Black	208	R	28	8	Green-Red
40	Black-Slate
15	Slate-Black
41	Yellow-Blue
16	Blue-Yellow
42	Yellow-Orange
17	Orange-Yellow
43	Yellow-Green	T	ET1	34	Red-Brown
18	Green-Yellow	R	ET1	9	Brown-Red
44	Yellow-Brown	T	ET2	35	Red-Slate
19	Brown-Yellow	R	ET2	10	Slate-Red
45	Yellow-Slate
20	Slate-Yellow
46	Violet-Blue
21	Blue-Violet
47	Violet-Orange
22	Orange-Violet
48	Violet-Green
23	Green-Violet
49	Violet-Brown
24	Brown-Violet
50	Violet-Slate	no connection
25	Slate-Violet	no connection

For an explanation of port numbering, see Port numbering on the wiring charts on page 60.

DTI wiring Connecting the DTI to the T1 service provider

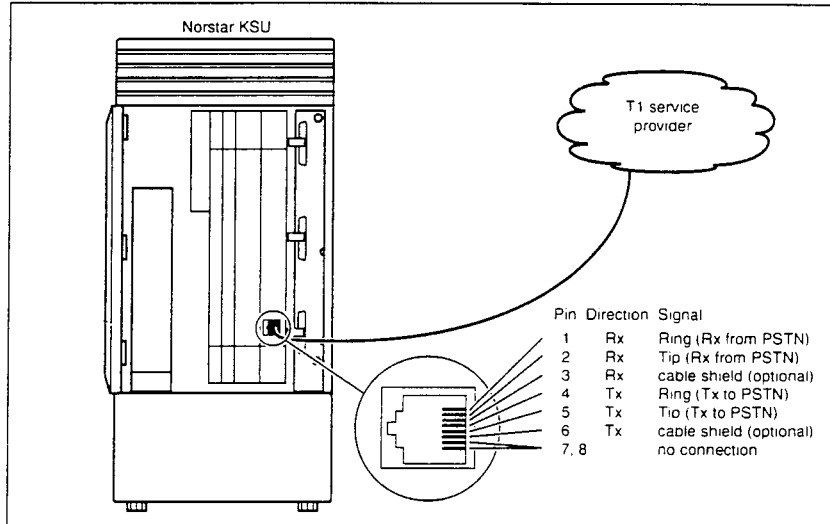

Connecting the DTI to an external CSU

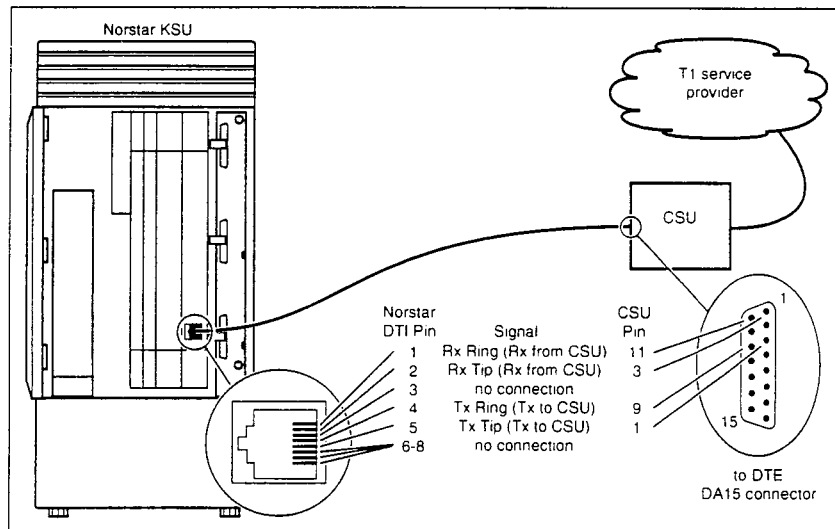

Station Module wiring chart

Pin	Wire color	Port	Service	Telephones (SM)
26	White-Blue	X01	T	1
1	Blue-White	X01	R	1
27	White-Orange	X02	T	2
2	Orange-White	X02	R	2
28	White-Green	X03	T	3
3	Green-White	X03	R	3
29	White-Brown	X04	T	4
4	Brown-White	X04	R	4
30	White-Slate	X05	T	5
5	Slate-White	X05	R	5
31	Red-Blue	X06	T	6
6	Blue-Red	X06	R	6
32	Red-Orange	X07	T	7
7	Orange-Red	X07	R	7
33	Red-Green	X08	T	8
8	Green-Red	X08	R	8
34	Red-Brown	X09	T	9
9	Brown-Red	X09	R	9
35	Red-Slate	X10	T	10
10	Slate-Red	X10	R	10
36	Black-Blue	X11	T	11
11	Blue-Black	X11	R	11
37	Black-Orange	X12	T	12
12	Orange-Black	X12	R	12
38	Black-Green	X13	T	13
13	Green-Black	X13	R	13
39	Black-Brown	X14	T	14
14	Brown-Black	X14	R	14
40	Black-Slate	X15	T	15
15	Slate-Black	X15	R	15
41	Yellow-Blue	X16	T	16
16	Blue-Yellow	X16	R	16
42	Yellow-Orange	----	----	no connection
17	Orange-Yellow	----	----	no connection
43	Yellow-Green	----	----	no connection
18	Green-Yellow	----	----	no connection
44	Yellow-Brown	----	----	no connection
19	Brown-Yellow	----	----	no connection
45	Yellow-Slate	----	----	no connection
20	Slate-Yellow	----	----	no connection
46	Violet-Blue	----	----	no connection
21	Blue-Violet	----	----	no connection
47	Violet-Orange	----	----	no connection
22	Orange-Violet	----	----	no connection
48	Violet-Green	----	----	no connection
23	Green-Violet	----	----	no connection
49	Violet-Brown	----	----	no connection
24	Brown-Violet	----	----	no connection
50	Violet-Slate	----	----	no connection
25	Slate-Violet	----	----	no connection

T and R represent station connections and should not be confused with Tip and Ring on external lines. Station connections are non-polarized.

For an explanation of port numbering, see Port numbering on the wiring charts on page 60.

Loop Start or CI Trunk Cartridge wiring chart

TM 50-pin connector arrangement					RJ-21 connector		
TC Slot	Pin	Wire color	Port	Service	Line	Pin	Wire color
Slot 1	26	White-Blue	X01	T	1	26	White-Blue
	1	Blue-White	X01	R	1	1	Blue-White
	27	White-Orange	X02	T	2	27	White-Orange
	2	Orange-White	X02	R	2	2	Orange-White
	28	White-Green	----	----	No connection	----	----
	3	Green-White	----	----	No connection	----	----
	29	White-Brown	----	----	No connection	----	----
	4	Brown-White	----	----	No connection	----	----
	30	White-Slate	X03	T	3	28	White-Green
	5	Slate-White	X03	R	3	3	Green-White
	31	Red-Blue	X04	T	4	29	White-Brown
	6	Blue-Red	X04	R	4	4	Brown-White
	32	Red-Orange	----	----	No connection	----	----
	7	Orange-Red	----	----	No connection	----	----
	33	Red-Green	----	----	No connection	----	----
	8	Green-Red	----	----	No connection	----	----
Slot 2	34	Red-Brown	X05	T	5	30	White-Slate
	9	Brown-Red	X05	R	5	5	Slate-White
	35	Red-Slate	X06	T	6	31	Red-Blue
	10	Slate-Red	X06	R	6	6	Blue-Red
	36	Black-Blue	----	----	No connection	----	----
	11	Blue-Black	----	----	No connection	----	----
	37	Black-Orange	----	----	No connection	----	----
	12	Orange-Black	----	----	No connection	----	----
	38	Black-Green	X07	T	7	32	Red-Orange
	13	Green-Black	X07	R	7	7	Orange-Red
	39	Black-Brown	X08	T	8	33	Red-Green
	14	Brown-Black	X08	R	8	8	Green-Red
	40	Black-Slate	----	----	No connection	----	----
	15	Slate-Black	----	----	No connection	----	----
	41	Yellow-Blue	----	----	No connection	----	----
	16	Blue-Yellow	----	----	No connection	----	----
Slot 3	42	Yellow-Orange	X09	T	9	34	Red-Brown
	17	Orange-Yellow	X09	R	9	9	Brown-Red
	43	Yellow-Green	X10	T	10	35	Red-Slate
	18	Green-Yellow	X10	R	10	10	Slate-Red
	44	Yellow-Brown	----	----	No connection	----	----
	19	Brown-Yellow	----	----	No connection	----	----
	45	Yellow-Slate	----	----	No connection	----	----
	20	Slate-Yellow	----	----	No connection	----	----
	46	Violet-Blue	X11	T	11	36	Black-Blue
	21	Blue-Violet	X11	R	11	11	Blue-Black
	47	Violet-Orange	X12	T	12	37	Black-Orange
	22	Orange-Violet	X12	R	12	12	Orange-Black
	48	Violet-Green	----	----	No connection	----	----
	23	Green-Violet	----	----	No connection	----	----
49	Violet-Brown	----	----	No connection	----	----	
24	Brown-Violet	----	----	No connection	----	----	
50	Violet-Slate	----	----	reserved	----	----	
25	Slate-Violet	----	----	reserved	----	----	

Auxiliary equipment cannot be connected to the RJ-21 connector.

For an explanation of port numbering, see Port numbering on the wiring charts on page 60

E&M/DISA Trunk Cartridge wiring chart

Use the following charts when a Trunk Module (TM) contains E&M/DISA Trunk Cartridges (TC) or a mixture of E&M/DISA and DID or Loop Start Trunk Cartridges.

Use the Trunk Module with E&M/DISA Trunk Cartridges and RJ2HX/CA2HA wiring connections table when a Trunk Module has only E&M/DISA Trunk Cartridges. It shows:

- the 50-pin connections on the TM
- the RJ2HX/CA2HA cross-connections

Read across the column headings to determine the cross-connections for E&M/DISA service.

Use the Example of E&M/DISA wiring with mixed service figure when a Trunk Module has a mixture of E&M/DISA, DID, and Loop Start Trunk Cartridges. Match the Service columns on the appropriate charts in the example to determine the cross-connection for mixed service.

If the Norstar system is being connected to another Norstar system or private branch exchange by connecting two RJ2HX/CA2HA distribution blocks together, use the following table to determine the required cross-connections.

Back-to-back cross-connections

1st distribution block	T	R	T1	R1	E	SG	M	SB
Next distribution block	T1	R1	T	R	SB	M	SG	E

Tips

When installing a mixture of E&M/DISA and DID or Loop Start Trunk Cartridges, it is important to cross-connect the wiring for each type of TC to a separate distribution block.

The cross-connections to each distribution block must always begin at pins 26 and 1. This allows you to wire to the correct pins for an RJ-21 connection and for an RJ2HX/CA2HA connection.

To retain emergency telephone function, install a Loop Start Trunk Cartridge in the left-most slot (slot 1) of the TM.

Trunk Module with E&M/DISA Trunk Cartridges and RJ2HX/CA2HA wiring connections

TM 50-pin connector arrangement						RJ2HX/CA2HA connector	
TC Slot	Pin	Wire color	Port	Service	Line	Pin	Wire color
Slot 1	26	White-Blue	X01	T	1	26	White-Blue
	1	Blue-White	X01	R	1	1	Blue-White
	27	White-Orange	X01	T1	1	27	White-Orange
	2	Orange-White	X01	R1	1	2	Orange-White
	28	White-Green	X01	E	1	28	White-Green
	3	Green-White	X01	SG	1	3	Green-White
	29	White-Brown	X01	M	1	29	White-Brown
	4	Brown-White	X01	SB	1	4	Brown-White
	30	White-Slate	X02	T	2	30	White-Slate
	5	Slate-White	X02	R	2	5	Slate-White
	31	Red-Blue	X02	T1	2	31	Red-Blue
	6	Blue-Red	X02	R1	2	6	Blue-Red
	32	Red-Orange	X02	E	2	32	Red-Orange
	7	Orange-Red	X02	SG	2	7	Orange-Red
	33	Red-Green	X02	M	2	33	Red-Green
	8	Green-Red	X02	SB	2	8	Green-Red
Slot 2	34	Red-Brown	X03	T	3	34	Red-Brown
	9	Brown-Red	X03	R	3	9	Brown-Red
	35	Red-Slate	X03	T1	3	35	Red-Slate
	10	Slate-Red	X03	R1	3	10	Slate-Red
	36	Black-Blue	X03	E	3	36	Black-Blue
	11	Blue-Black	X03	SG	3	11	Blue-Black
	37	Black-Orange	X03	M	3	37	Black-Orange
	12	Orange-Black	X03	SB	3	12	Orange-Black
	38	Black-Green	X04	T	4	38	Black-Green
	13	Green-Black	X04	R	4	13	Green-Black
	39	Black-Brown	X04	T1	4	39	Black-Brown
	14	Brown-Black	X04	R1	4	14	Brown-Black
	40	Black-Slate	X04	E	4	40	Black-Slate
	15	Slate-Black	X04	SG	4	15	Slate-Black
	41	Yellow-Blue	X04	M	4	41	Yellow-Blue
	16	Blue-Yellow	X04	SB	4	16	Blue-Yellow
Slot 3	42	Yellow-Orange	X05	T	5	42	Yellow-Orange
	17	Orange-Yellow	X05	R	5	17	Orange-Yellow
	43	Yellow-Green	X05	T1	5	43	Yellow-Green
	18	Green-Yellow	X05	R1	5	18	Green-Yellow
	44	Yellow-Brown	X05	E	5	44	Yellow-Brown
	19	Brown-Yellow	X05	SG	5	19	Brown-Yellow
	45	Yellow-Slate	X05	M	5	45	Yellow-Slate
	20	Slate-Yellow	X05	SB	5	20	Slate-Yellow
	46	Violet-Blue	X06	T	6	46	Violet-Blue
	21	Blue-Violet	X06	R	6	21	Blue-Violet
	47	Violet-Orange	X06	T1	6	47	Violet-Orange
	22	Orange-Violet	X06	R1	6	22	Orange-Violet
	48	Violet-Green	X06	E	6	48	Violet-Green
23	Green-Violet	X06	SG	6	23	Green-Violet	
49	Violet-Brown	X06	M	6	49	Violet-Brown	
24	Brown-Violet	X06	SB	6	24	Brown-Violet	
50	Violet-Slate	----	reserved	----	----	----	----
25	Slate-Violet	----	reserved	----	----	----	----

Auxiliary equipment cannot be connected to the RJ2HX/CA2HA connector.

For an explanation of port numbering, see Port numbering on the wiring charts on page 60.

Example of E&M/DISA wiring with mixed service

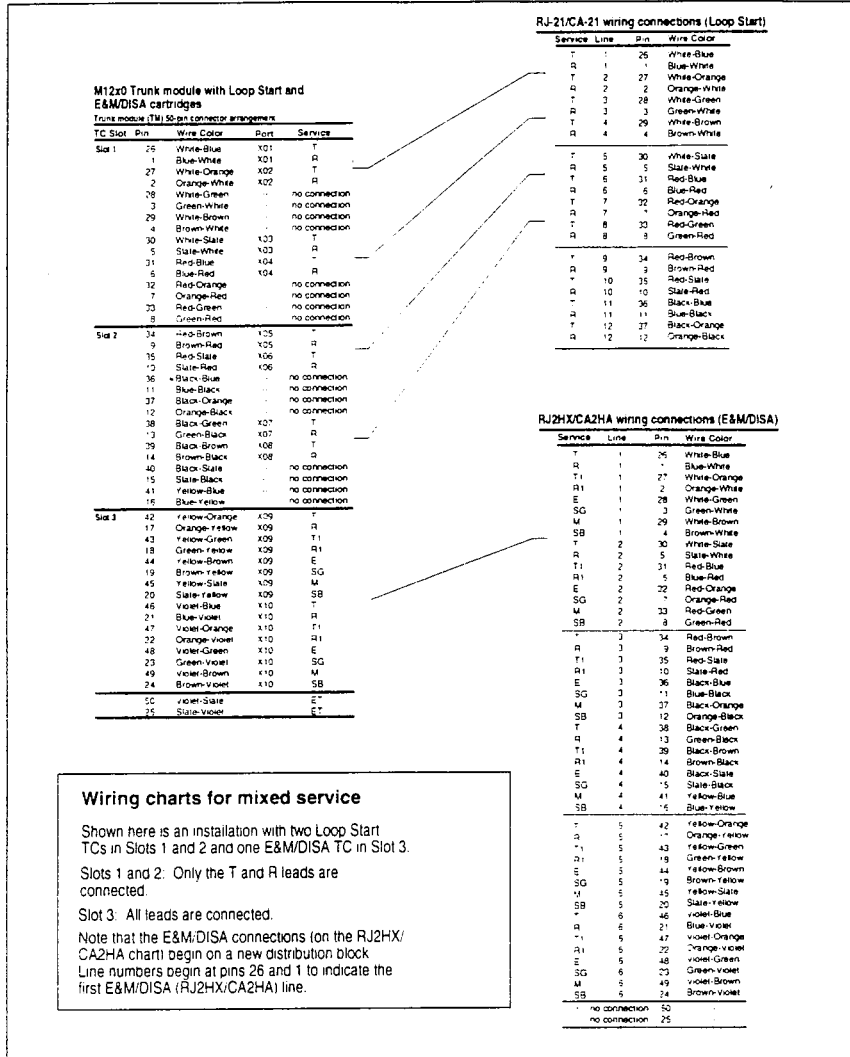

Wiring charts for mixed service

Shown here is an installation with two Loop Start TCs in Slots 1 and 2 and one E&M/DISA TC in Slot 3.

Slots 1 and 2: Only the T and R leads are connected.

Slot 3: All leads are connected.

Note that the E&M/DISA connections (on the RJ2HX/CA2HA chart) begin on a new distribution block. Line numbers begin at pins 26 and 1 to indicate the first E&M/DISA (RJ2HX/CA2HA) line.

DID Trunk Cartridge wiring chart

Use the following charts when a Trunk Module (TM) contains DID Trunk Cartridges or a mixture of DID and E&M/DISA or Loop Start Trunk Cartridges.

Use the Trunk Module with DID Trunk Cartridges and RJ-21 wiring connections chart when a TM has only DID Trunk Cartridges. It shows:

- the 50-pin connections on the TM
- the RJ-21 cross-connections

Read across the column headings to determine the cross-connections for DID service.

Use the Example of DID wiring chart with mixed service when a Trunk Module has a mixture of DID, and E&M/DISA or Loop Start Trunk Cartridges. Match the Service columns on the appropriate charts in the example to determine the cross-connection for mixed service.

Tips

When installing a mixture of DID and E&M/DISA or Loop Start Trunk Cartridges, it is important to cross-connect the wiring for each type of TC to a separate distribution block.

The cross-connections to each distribution block must always begin at pins 26 and 1. This allows you to wire to the correct pins for an RJ-21 connection and for an RJ2HX/CA2HA connection.

To retain emergency telephone function, install a Loop Start Trunk Cartridge in the left-most slot (slot 1) of the TM.

DID supervisory signaling

This equipment is designed to return supervisory signals to the public switched telephone network (PSTN) when the DID calls are:

- answered by the called telephone
- answered by the attendant
- routed to a customer controlled recorded announcement
- routed to a dial prompt

This equipment is designed to return supervisory signals on all DID calls forwarded through the system back to the PSTN within 20 seconds of the call forwarding sequence being initiated.

Allowing this equipment to be operated in a manner that does not provide for proper answer supervision signaling violates FCC Part 68 Rules, and may violate local tariffs.

Emergency transfer conditions

Every DID Trunk Cartridge has a Control Circuit Interface (CCI) which should be connected directly to the central office for monitoring purposes.

If the Norstar system loses power or the microcontroller on the DID Trunk Cartridge malfunctions, the CCI signals the central office that it can no longer handle DID calls. The central office, by prearrangement, can then forward the DID lines to other numbers.

Connect the CCI com1 connection to a ground connection. Connect the CCI NC1 connection to the central office demarcation.

Tips

The CCI signaling to report power loss or malfunction of the DID Trunk Cartridge is not supported by all carriers. For carriers or installations which do not use CCI signaling, the CCI and ET connections should be treated as “no connection”.

Wire each CCI independently to the central office. If the connections are wired in parallel, any CCI trouble disables all DID Trunk Cartridges. If the connections are wired in series, all DID Trunk Cartridges must fail before the central office recognizes the trouble condition.

Trunk Module with DID Trunk Cartridges and RJ-21 wiring connections

TM 50-pin connector arrangement					RJ-21 connector			
TC Slot	Pin	Wire color	Port	Service	Line	Pin	Wire color	
Slot 1	26	White-Blue	X01	T	1	26	White-Blue	
	1	Blue-White	X01	R	1	1	Blue-White	
	27	White-Orange	X02	T	2	27	White-Orange	
	2	Orange-White	X02	R	2	2	Orange-White	
	28	White-Green	----	----	No connection	----	----	
	3	Green-White	----	----	No connection	----	----	
	29	White-Brown	----	----	CCI NC1	----	28	White-Green
	4	Brown-White	----	----	CCI Com1	----	3	Green-White
	30	White-Slate	X03	T	3	29	White-Brown	
	5	Slate-White	X03	R	3	4	Brown-White	
	31	Red-Blue	X04	T	4	30	White-Slate	
	6	Blue-Red	X04	R	4	5	Slate-White	
	32	Red-Orange	----	----	No connection	----	----	
	7	Orange-Red	----	----	No connection	----	----	
	33	Red-Green	----	----	No connection	----	----	
	8	Green-Red	----	----	No connection	----	----	
Slot 2	34	Red-Brown	X05	T	5	31	Red-Blue	
	9	Brown-Red	X05	R	5	6	Blue-Red	
	35	Red-Slate	X06	T	6	32	Red-Orange	
	10	Slate-Red	X06	R	6	7	Orange-Red	
	36	Black-Blue	----	----	No connection	----	----	
	11	Blue-Black	----	----	No connection	----	----	
	37	Black-Orange	----	----	CCI NC1	----	33	Red-Green
	12	Orange-Black	----	----	CCI Com1	----	8	Green-Red
	38	Black-Green	X07	T	7	34	Red-Brown	
	13	Green-Black	X07	R	7	9	Brown-Red	
	39	Black-Brown	X08	T	8	35	Red-Slate	
	14	Brown-Black	X08	R	8	10	Slate-Red	
	40	Black-Slate	----	----	No connection	----	----	
	15	Slate-Black	----	----	No connection	----	----	
	41	Yellow-Blue	----	----	No connection	----	----	
	16	Blue-Yellow	----	----	No connection	----	----	
Slot 3	42	Yellow-Orange	X09	T	9	36	Black-Blue	
	17	Orange-Yellow	X09	R	9	11	Blue-Black	
	43	Yellow-Green	X10	T	10	37	Black-Orange	
	18	Green-Yellow	X10	R	10	12	Orange-Black	
	44	Yellow-Brown	----	----	No connection	----	----	
	19	Brown-Yellow	----	----	No connection	----	----	
	45	Yellow-Slate	----	----	CCI NC1	----	38	Black-Green
	20	Slate-Yellow	----	----	CCI Com1	----	13	Green-Black
	46	Violet-Blue	X11	T	11	39	Black-Brown	
	21	Blue-Violet	X11	R	11	14	Brown-Black	
	47	Violet-Orange	X12	T	12	40	Black-Slate	
	22	Orange-Violet	X12	R	12	15	Slate-Black	
	48	Violet-Green	----	----	No connection	----	----	
	23	Green-Violet	----	----	No connection	----	----	
	49	Violet-Brown	----	----	No connection	----	----	
	24	Brown-Violet	----	----	No connection	----	----	
50	Violet-Slate	----	----	ET	----	No connection		
25	Slate-Violet	----	----	ET	----	No connection		

Auxiliary equipment cannot be connected to the RJ-21 connector.

For an explanation of port numbering, see Port numbering on the wiring charts on page 60.

For CCI connections in Service column: NC1 stands for the normally closed relay and Com1 the common relay. CCI signaling is not supported by all carriers. For carriers or installations that do not use CCI signaling, the CCI and ET connections should be treated as "no connection". CCI wiring is a non-standard wiring arrangement which has been submitted to the DOC.

Example of DID wiring chart with mixed service

M12x0 Trunk module with DID and E&M/DISA card/edges

Trunk module (TM) 50 pin connector arrangement

TC Slot	Pin	Wire Color	Port	Service
Slot 1				
26	1	White-Blue	X01	R
27	2	White-Orange	X02	T
28	3	White-Green	..	no connection
29	4	White-Brown	..	no connection
30	5	White-Slate	..	no connection
31	6	White-White	..	no connection
32	7	White-Red	..	no connection
33	8	White-Black	..	no connection
Slot 2				
34	9	White-Black	X05	R
35	10	White-Red	X06	T
36	11	White-Blue	..	no connection
37	12	White-Orange	..	no connection
38	13	White-Green	..	no connection
39	14	White-Brown	..	no connection
40	15	White-Slate	..	no connection
41	16	White-White	..	no connection
42	17	White-Red	..	no connection
43	18	White-Black	..	no connection
Slot 3				
44	19	White-Orange	X09	R
45	20	White-Green	X09	T
46	21	White-Brown	X09	E
47	22	White-Slate	X09	M
48	23	White-White	X09	SB
49	24	White-Red	X10	T
50	25	White-Black	X10	R
51	26	White-Blue	X10	T
52	27	White-Orange	X10	T
53	28	White-Green	X10	E
54	29	White-Brown	X10	SG
55	30	White-Slate	X10	M
56	31	White-White	X10	SB
57	32	White-Red	..	no connection
58	33	White-Black	..	no connection

RJ-21/CA-21 wiring connections (DID)

Service	Line	Pin	Wire Color
T	1	26	White-Blue
R	1	1	Blue-White
T	2	27	White-Orange
R	2	2	Orange-White
CCI	1	28	White-Green
CCI	1	3	Green-White
T	3	29	White-Brown
R	3	4	Brown-White
T	4	30	White-Slate
R	4	5	Slate-White
T	5	31	Red-Blue
R	5	6	Blue-Red
T	6	32	Red-Orange
R	6	7	Orange-Red
CCI	1	33	Red-Green
CCI	1	8	Green-Red
T	7	34	Red-Brown
R	7	9	Brown-Red
T	8	35	Red-Slate
R	8	10	Slate-Red
T	9	36	Black-Blue
R	9	11	Blue-Black
T	10	37	Black-Orange
R	10	12	Orange-Black
CCI	1	38	Black-Green
CCI	1	13	Green-Black
T	11	39	Black-Brown
R	11	14	Brown-Black
T	12	40	Black-Slate
R	12	15	Slate-Black

RJ2HX/CA2HA wiring connections (E&M/DISA)

Service	Line	Pin	Wire Color
T	1	26	White-Blue
R	1	1	Blue-White
T	1	27	White-Orange
R	1	2	Orange-White
E	1	28	White-Green
SG	1	3	Green-White
M	1	29	White-Brown
SB	1	4	Brown-White
T	2	30	White-Slate
R	2	5	Slate-White
T	2	31	Red-Blue
R	2	6	Blue-Red
E	2	32	Red-Orange
SG	2	7	Orange-Red
M	2	33	Red-Green
SB	2	8	Green-Red
T	3	34	Red-Brown
R	3	9	Brown-Red
T	3	35	Red-Slate
R	3	10	Slate-Red
E	3	36	Black-Blue
SG	3	11	Blue-Black
M	3	37	Black-Orange
SB	3	12	Orange-Black
T	4	38	Black-Green
R	4	13	Green-Black
T	4	39	Black-Brown
R	4	14	Brown-Black
E	4	40	Black-Slate
SG	4	15	Slate-Black
M	4	41	Yellow-Blue
SB	4	16	Blue-Yellow
T	5	42	Yellow-Orange
R	5	17	Orange-Yellow
T	5	43	Yellow-Green
R	5	18	Green-Yellow
E	5	44	Yellow-Brown
SG	5	19	Brown-Yellow
M	5	45	Yellow-Slate
SB	5	20	Slate-Yellow
T	5	46	White-Blue
R	5	21	Blue-White
T	5	47	White-Orange
R	5	22	Orange-White
E	5	48	White-Green
SG	5	23	Green-White
M	5	49	White-Brown
SB	5	24	Brown-White
..	..	50	..
..	..	25	..

Wiring charts for mixed service

Shown here is an installation with two DID TCs in Slots 1 and 2 and one E&M/DISA TC in Slot 3.

Slots 1 and 2: Only the T, R, and CCI leads are connected.

Slot 3: All leads are connected.

Note that the E&M/DISA connections (on the RJ2HX/CA2HA chart) begin on a new distribution block. Line numbers begin at pins 26 and 1 to indicate the first E&M/DISA (RJ2HX/CA2HA) line.

Installing telephones

Installing the emergency telephone

You can connect an emergency telephone to a KSU or Trunk Module with a Loop Start Trunk Cartridge, to provide emergency service when there is no power to the KSU. The KSU has emergency telephone connections for lines 002 and 026. Each Trunk Module has one emergency telephone connection.

1. Wire a modular jack or equivalent to each set of emergency telephone pins on the 50-pin distribution block for the KSU or Trunk Module external lines. (See the wiring charts for the pin numbers.)
2. Connect a single-line telephone (500/2500) to the modular jack.
3. With the system power off, pick up the telephone receiver and listen for dial tone.

Tips

The emergency telephone connections on the Trunk Module will not work if there is an E&M/DISA or DID Trunk Cartridge in the first slot of the Trunk Module.

The emergency telephone connections on the KSU will not work if DTIs are used.

Installing Norstar telephones

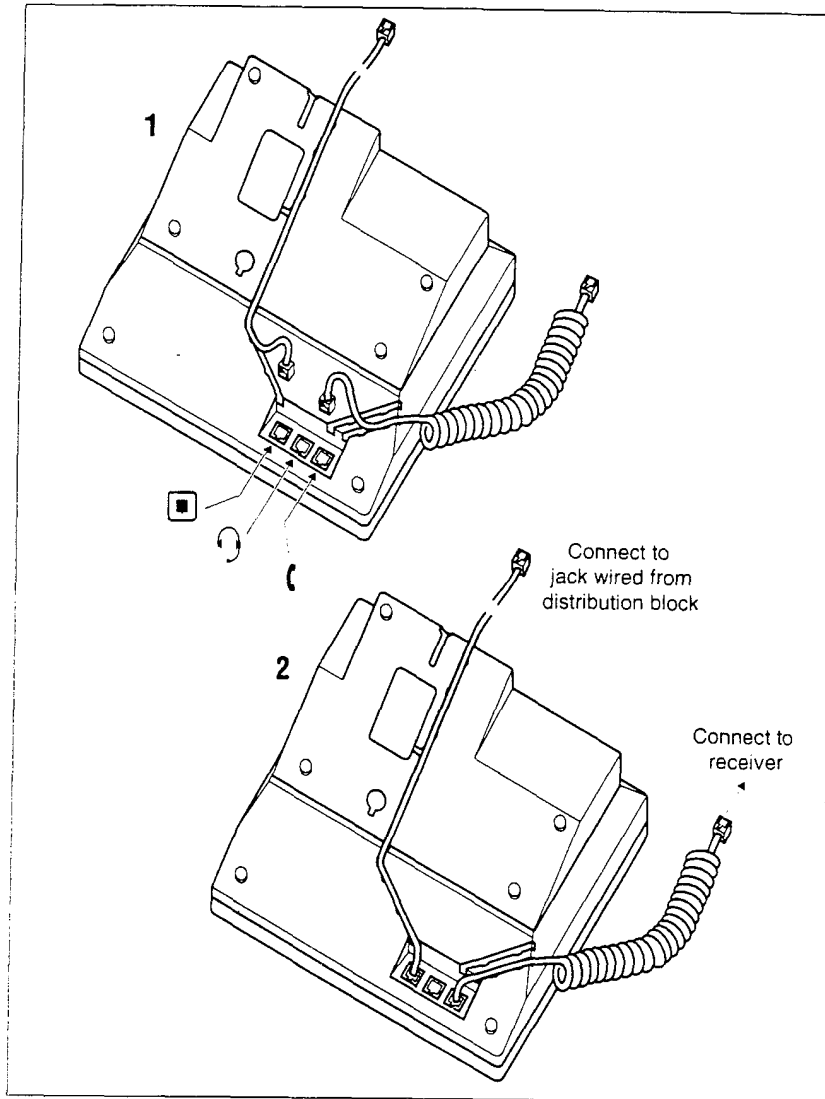

Tips

Norstar telephones cannot be used as off-premise extensions (OPX). For OPX applications, use the Norstar Analog Terminal Adapter (ATA) and a single-line telephone. See the *Norstar ATA Installation Card* for details.

Mounting Norstar telephones on the wall

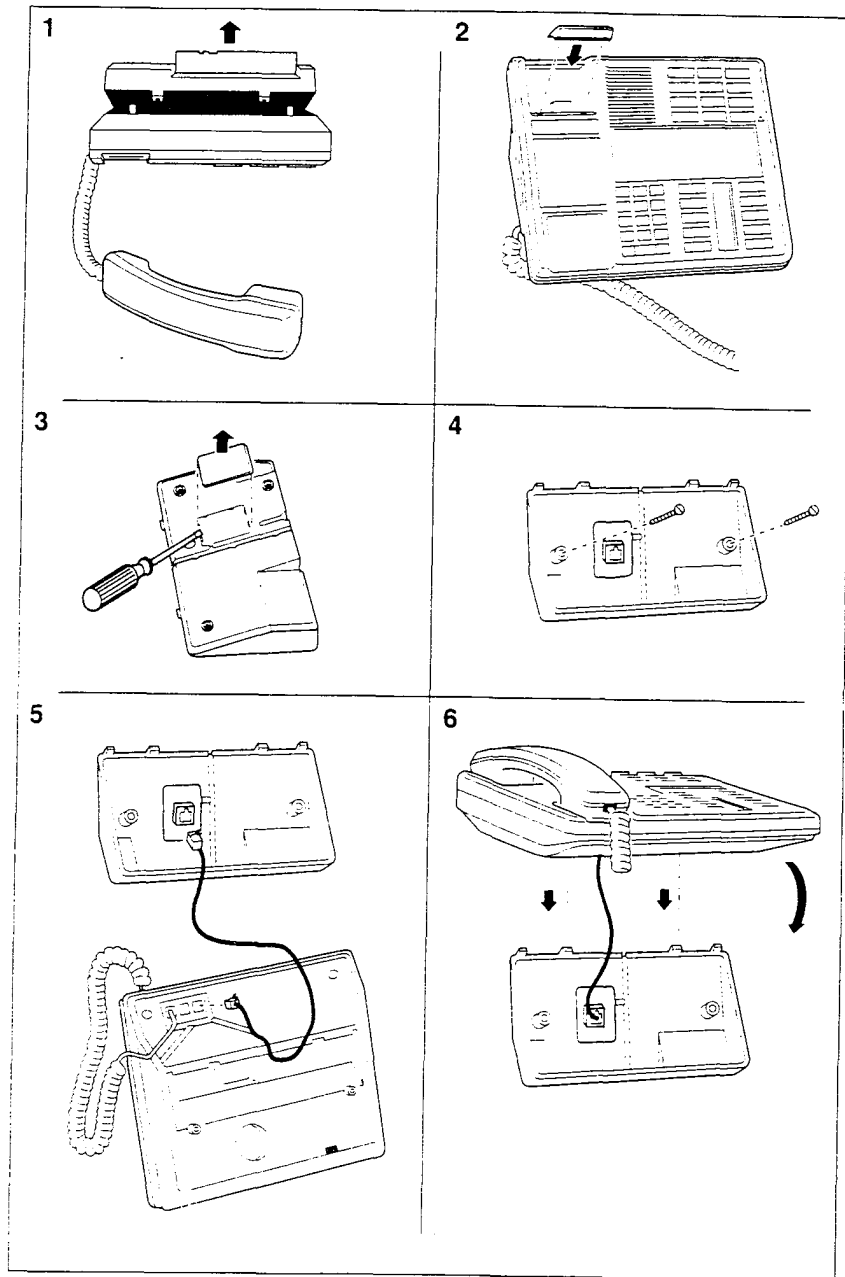

Moving Norstar telephones

You can move a Norstar telephone to a new location within the Norstar system without losing its programmed settings. When Set relocation (automatic telephone relocation) is enabled in Configuration programming, the internal numbers, autodial settings, and personal speed dial codes remain with the telephone when it is unplugged. To move a telephone, simply unplug it and plug it in again at another location. It may take up to 45 seconds for the KSU to recognize the telephone. Automatic Telephone Relocation is disabled by default.

Tips

All Norstar telephones being moved should be relocated before new telephones are plugged into their place. This allows the moved telephones to retain their programmed settings. If a new telephone is plugged into the Norstar system before the old telephone is reconnected at a new location, Norstar will give the old telephone's information to the new telephone, and the old telephone will no longer be recognized by the system.

When changing a telephone's internal number (in Configuration programming), wait one minute after Automatic Telephone Relocation.

When you relocate a Norstar telephone, the telephone must remain installed and connected in the new location for at least 3 minutes for the programming relocation to be complete. Moving the telephone again before the 3 minute period may result in losing the telephone's programming.

Installing optional equipment

Auxiliary ringer (customer supplied)

The Norstar KSU provides a control contact to operate an auxiliary ringer.

1. Follow the manufacturer's installation instructions.
2. Connect the auxiliary ring generator to the 50-pin distribution block as shown in the wiring charts.

The pins in this chart provide a control contact. They do not provide ring current or dc voltage. The ringer must not draw more than 50 mA from a 40 V dc source.

Auxiliary ringer programming

The auxiliary ringer can be activated by setting auxiliary ring for specific external lines, and auxiliary ring for specific telephones. Refer to the Programming chapter and the *System Coordinator Guide* for programming details.

Heading	Programmed in:
1. Trk/Line Data	Configuration
5. Capabilities	Administration
6. Service Modes	Administration

External music source (customer supplied)

The music source can be any approved low-power device such as a radio with a high-impedance earphone jack. The recommended KSU input level is 0.25 V rms across an input impedance of 3300 Ω .

1. Connect the music source output to the 50-pin distribution block, as shown in the wiring charts.
2. Adjust the volume of the music source to a comfortable level by activating Background Music (8 6) and adjusting the volume at the music source.

Tips

Background Music volume can also be adjusted at each telephone.

External music source programming

Music for callers on Hold and for Background Music must be enabled through programming. Refer to the Programming chapter for more details. Refer specifically to the following programming headings in Configuration and confirm that the following settings are implemented:

Heading	Setting
4. Call Handling	On hold: Music
5. Miscellaneous	Backgrnd music: Y

External paging system (customer supplied)

You can connect an external paging system to provide paging over external loudspeakers. The paging output from the Norstar KSU is 775 mV rms across an input impedance of 600 Ω .

1. Follow the manufacturer's installation instructions.
2. Connect the paging system audio input to the 50-pin distribution block as shown in the wiring charts.
3. Connect the paging system relay to the 50-pin distribution block as shown in the wiring charts.

External paging contacts

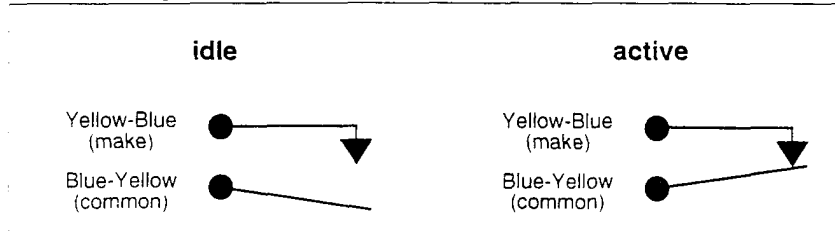

Tips

Norstar external paging does not support talk-back paging equipment unless an external line port is used.

The Norstar system provides paging over the Norstar telephone speakers, even when no external paging equipment is connected.

Powering up the system

1. Double-check all wiring before turning the system power on.
2. Route the TM and SM power cords through the lower shelf of the cable trough and out through the bottom of the KSU cable trough.
3. Route the KSU power cord through the bottom of the KSU cable trough.
4. Connect each power cord (KSU, TM and SM) to an electrical outlet (non-switchable, third-wire ground ac outlet).

If you are using a power bar, plug the power cords into the power bar and connect the power bar to the ac outlet.

	<p style="text-align: center;">Do not fasten power supply cords</p> <p>To comply with UL1459, do not fasten the KSU power supply cord or Module power supply cords to any building surface, including the backboard.</p>
--	---

5. Check that the power LEDs on the KSU, TM and SM are on.

	<p style="text-align: center;">Close and lock the KSU door</p> <p>Close and lock the KSU door after installation is complete to avoid accidental shock and to provide containment in the event of fire.</p>
---	--

Tips

You can install the power bar in the lower shelf of the TM or SM cable trough and route the power cord out through the bottom of the KSU cable trough.

If you need more than one power bar, plug the second power bar into an outlet on the first power bar.

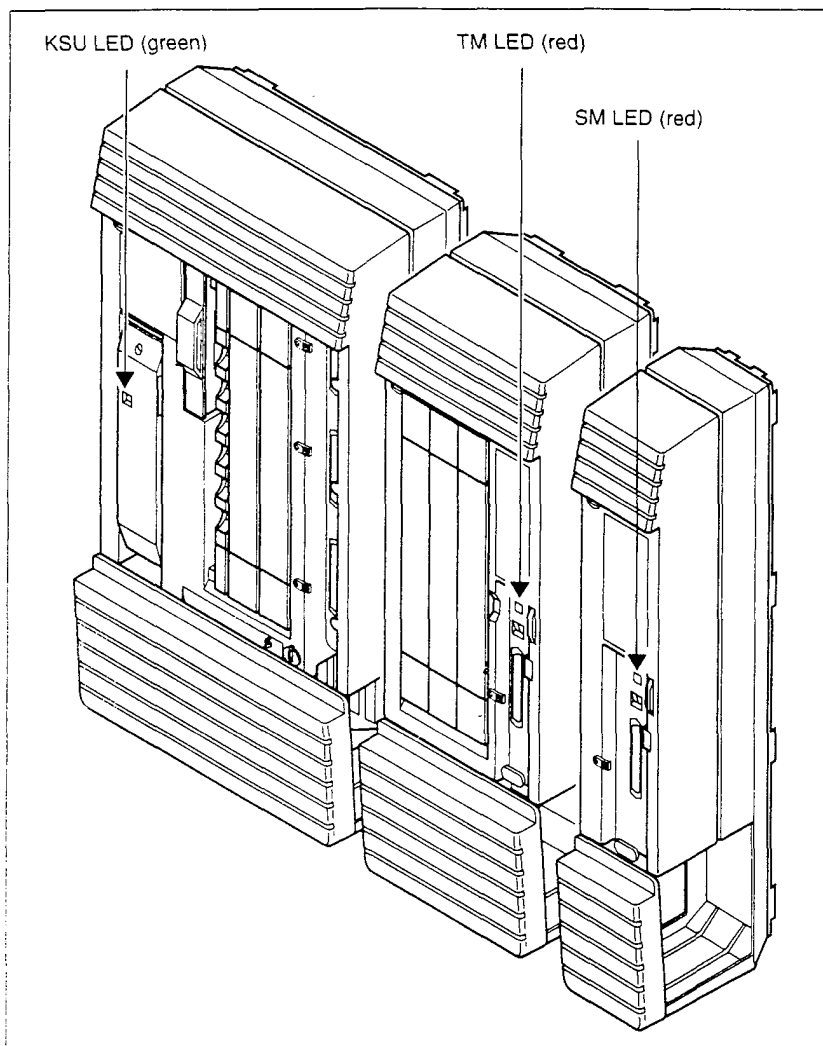

Once the system is initialized and the telephone displays read Jan 1 1:00 am, you have fifteen minutes in which to perform Startup programming. After 15 minutes, access to Startup programming is denied. You can turn the system power off and back on if you need to access Startup programming after this point.

Programming

Programming is performed by the installer or the customer service representative, and lets you change settings for the entire Norstar system, as well as settings for individual telephones and external lines.

	<p style="text-align: center;">Programming affects system operation</p> <p>Only a qualified installer or customer service representative should perform Startup, Configuration and Maintenance programming. Some of the settings affect the correct operation of the system.</p>
---	---

This chapter contains information for programming Startup, Configuration and Maintenance settings. If you are new to programming, you may want to practice using the detailed Administration programming procedures in the *System Coordinator Guide* before attempting other procedures.

For information on Administration programming, and personal programming, see the *System Coordinator Guide*.

Programming overview

Startup			
Template			
Start DN			
A. Configuration	B. General admin	C. Set copy	D. Maintenance
1. Trk/Line Data	1. Sys speed dial		1. System Version
2. Line Access	2. Names		2. Port/DN Status
3. Routing	3. Time and Date		3. Module Status
4. Call Handling	4. Direct-Dial		4. Sys Test Log
5. Miscellaneous	5. Capabilities		5. Sys Admin Log
6. System Data	6. Service Modes		6. Network Log
	7. Passwords		7. Clock Source
	8. Log Defaults		8. Provisioning
	9. Call Services		9. Loopback Tests
			10. CSU Stats

Programming tools

A Norstar telephone

Programming is done at an M7310 or M7324 telephone. Use the buttons on the telephone to program a setting or to request a specific programming action. Norstar guides you step-by-step with instructions on the telephone display while you are programming.

The programming overlay

The programming overlay is a paper cutout that labels four telephone buttons used during programming. The programming overlay is provided at the end of this book.

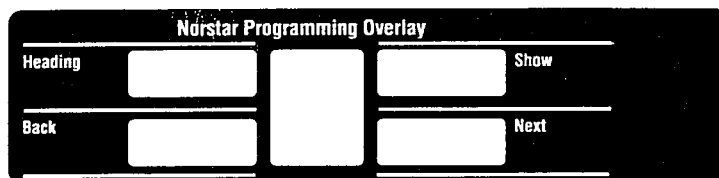

M7310 telephone with a programming overlay

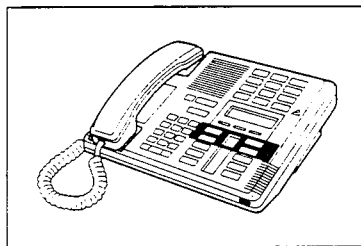

M7324 telephone with a programming overlay

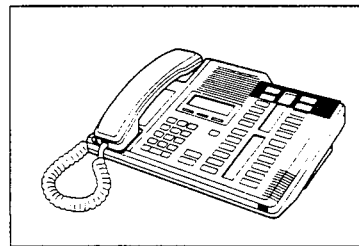

The indicators on the M7310 or M7324 telephone show which buttons can be used at that programming step. The functions on these buttons allow you to move through the headings and subheadings of Norstar programming.

Heading	moves up in the hierarchy of headings and subheadings.
Show	moves down in the hierarchy of headings and subheadings, or begins programming for a heading or subheading.
Next	moves to the next heading, subheading, or setting.
Back	moves to the previous heading, subheading, or setting.

The Norstar display buttons

Display buttons on the M7310 and M7324 telephones perform many functions. Depending on where you are in programming, one, two, or three display buttons may be available at any one time. You press one of the display buttons to select the function that you want.

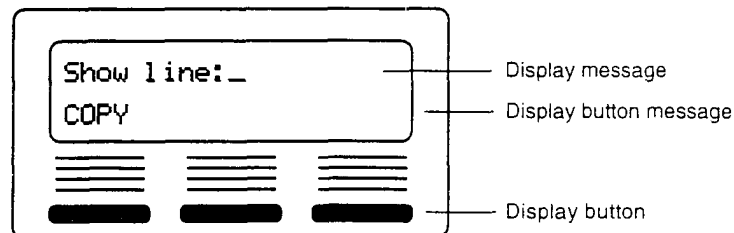

The most common display button labels are:

<u>CHANGE</u>	changes a programmable setting
<u>BKSP</u>	moves the cursor one space to the left (backspace) and deletes a character, allowing you to re-enter a number or letter
<u>COPY</u>	copies line or telephone programming
<u>VIEW→</u>	views the last part of a displayed message longer than 16 characters
<u>←VIEW</u>	views the first part of a displayed message longer than 16 characters
<u>--></u>	moves the cursor one position to the right when programming a name
<u><--</u>	moves the cursor one position to the left when programming a name

The Norstar Programming Record

The *Programming Record* provides a convenient way to record what you have programmed. It also helps you to plan your programming.

Pages from the record may be photocopied as necessary for programming many telephones or lines.

Exiting programming

Norstar stores your changes automatically as soon as you alter any settings; you do not need to "save" your changes.

1. Press **RI***. The display briefly reads **End of session**.

Entering numbers

Numbers are entered from the Norstar telephone dial pad. The backspace display button may be used to edit the number.

A line number must always be entered as a three-digit number. Line numbers from 10 to 99 must be entered with a leading zero (line 020, for example). Similarly, line numbers less than 10 must be entered with two leading zeros (line 002, for example).

Internal telephone numbers, also referred to as directory numbers (DNs), can be two to seven digits long on a non-expanded system, and three to seven digits long on an expanded system. The default DN length is two on a non-expanded system and three on an expanded system. The DN length can be changed in Configuration programming.

Viewing long telephone numbers

External telephone numbers can be up to 24 digits, but the telephone display is only 16 character spaces long. If you wish to see a previously programmed number that is longer than 16 digits, you must do the following:

Begin, for example, with 123456789012345.... The display shows only the first 15 digits. The three dots (...) at the end of the display indicate that more digits remain to the external number.

1. To see the remaining digits, press **VIEW**.
2. To see the first 15 digits again, press **←VIEW**.

Reviewing programmed settings

The Set Profile and Line Profile features help you to check your programming by allowing you to review the settings.

Programming that can be reviewed

Set Profile	Line Profile
Set name	Line name
Line Access	Trunk data
Set abilities	Line data
Set services	Line abilities
	Service Modes
	Call Info set
	Voice message center

Viewing the programming for a telephone

From an M7310 or M7324 telephone:

1. Press **Feature** ***** ***** **S** **E** **T**. The display reads **Show set:.**
2. Enter the internal number of the telephone you wish to review.
3. Use **BACK**, **NEXT**, and **SHOW** to navigate through the settings.
4. Press **Ris** to exit.

Viewing the programming for a line

From an M7310 or M7324 telephone:

1. Press **Feature** ***** ***** **L** **I** **N** **E**. The display reads **Show line:.**
2. Enter the number of the line you wish to review.
3. Use **BACK**, **NEXT**, and **SHOW** to navigate through the settings.
4. Press **Ris** to exit.

Template defaults

The five templates available in the Norstar system are Square, Centrex, Hybrid, PBX, and DID. The following charts show the default settings for each template.

Square defaults are listed in full. Centrex, Hybrid, PBX, and DID defaults are listed only when they differ from Square defaults.

Where a DN is specified, it is the three-digit DN that is the default on an expanded system. (Two-digit DNs are the default on non-expanded systems.)

Startup defaults

Setting	Default
Template	Square
Start DN	221

Configuration defaults

Trunk Cartridge configuration (Trk/Line data)

Setting	Square	Centrex	Hybrid	PBX	DID
TCs on	KSU				
TCx on KSU	Loop				
TCx on TMx	Loop				
Discon timer	460 milliseconds				
Answer timer	2 seconds				
CO fail	TIA-547A				
Framing	ESF				
Internal CSU	ON				
CSU line bld	0 dB				
DSX1 bld	000-100 feet				
Line coding	B8ZS				

Trunk data (Trk/Line data)

Setting	Square	Centrex	Hybrid	PBX	DID
Line <xxx> (Trunk type)	Loop				
Trunk mode	Unsupervised				
Ans mode	Manual				
Ans with DISA	Yes				
Signal	WinkStart				
ANI Number	No				
DNIS Number	No				
Gain	Normal				
Dial mode	Pulse				
Full AutoHold	No				
LossPkg	MediumCO				
Rec'd #	None				DN of the set it appears on

Line data (physical and target lines)

Setting	Square	Centrex	Hybrid	PBX	DID
Line type	Public	Public	Lines 001 to 024: Pool A 025 to 048: Pool B 049 to 052: Pool C 053 to 056: Pool D 057 to 060: Pool E 061 to 064: Pool F 065 to 068: Pool G 069 to 072: Pool H 073 to 076: Pool I 077 to 080: Pool J 081 to 084: Pool K 085 to 088: Pool L 089 to 092: Pool M 093 to 096: Pool N 097 to 100: Pool O 101 to 120: Public 121 to 248: Public	Pool †	Lines 001 to 024: Pool A Lines 025 to 120: Public Lines 121to 248: Public
Line grp	None				
Prime set	Set 221(for each line)				
Aux. ringer	Yes (for each line)				
Auto privacy	Yes (for each line)				

† Target lines cannot be placed into line pools.

Line Access

Setting	Square	Centrex	Hybrid	PBX	DID
Line assignment	Lines 001 to 002: Appear & Ring All other external lines: Not assignd Lines 121 to 248: Not assignd	Line <nnn> † Appear & Ring All other external lines: Not assignd Lines 121 to 248: Not assignd	Set 221 Lines 001: Appear & Ring All other external lines: Not assignd Lines 121 to 248: Not assignd All other sets Lines 001: Appear only All other external lines: Not assignd Lines 121 to 248: Not assignd	All external lines: Not assignd Lines 121 to 248: Not assignd	All external lines: Not assignd Assoc-iated Target line: Ring only
ILG assignment	Line groups 01 to 15: All lines Not assigned				
Answer DNS	Not assigned				
Line pool access	No	No	Yes (Pool A)		
Intercom keys	2				
Prime line	None	Line <nnn> †	Intercom	Intercom	Intercom

† <nnn> is a three-digit line number. The Centrex template sequentially assigns lines to DNS. It assigns Line 001 to DN 221, Line 002 to DN 222, and so on, until all lines are assigned to DNS. The lines automatically become prime lines for the DNS.

Routing

Setting	Square	Centrex	Hybrid	PBX	DID
Route number	no defaults assigned				
Use	Pool A				
DialOut	no defaults assigned				
DestCode	no defaults assigned				
Use route	200 (for normal mode)				

Call Handling

Setting	Square	Centrex	Hybrid	PBX	DID
Held reminder	No				
Remind delay (presented if Held reminder is changed to Yes)	60 seconds				
DRT to prime	Yes				
DRT delay	3 rings				
Transfr callbk	3 rings				
Park prefix	1				
Park timeout	45 seconds				
Camp timeout	45 seconds				
Directd pickup	Yes				
On hold	Tones				

Miscellaneous

Setting	Square	Centrex	Hybrid	PBX	DID
Backgrnd music	No				
Direct-dial #	0				
DISA DN	None				
Auto DN	None				
Alarm set	Set 221				
CAP assignment	None				
Link time	600 milliseconds				
Set relocation	No				
Host delay	1000 milliseconds				
Receiver volume	Use systm volume				
External code	9				
Line pool codes	None	None	9 for Pool A None for Pools B to O	9 for Pool A None for Pools B to O	9 for Pool A None for Pools B to O
Installer pswd.	C O N F I G OR 2 6 6 3 4 4				

System Data

Setting	Square	Centrex	Hybrid	PBX	DID
Individual DNs	Individual DNs may be changed.				
DN length	2 (non-expanded system) 3 (expanded system)				
Rec'd # length	2 (non-expanded system) 3 (expanded system)				

General Administration defaults

System speed dial

Setting	Square	Centrex	Hybrid	PBX	DID
Speed dial #	(no defaults assigned)				
Use	prime line				
Display digits	Yes				
Name (presented if Display digits is changed to No)	Sys Spd Dial <#nn> <#nn> is a two-digit system speed dial code (#12, for example).				
Bypass restr'n	No				

Names

Setting	Square	Centrex	Hybrid	PBX	DID
Set names	DN (221, for example)				
Line names	Line number (Line 001, for example)				

Time and Date

The default time and date is: 1:00 a.m., January 1st, 1994

Direct-Dial

Setting	Square	Centrex	Hybrid	PBX	DID
D-Dial1	Intrnl #: 221				
D-Dial2, D-Dial3 D-Dial4, D-Dial5	None				

Dialing filters (Capabilities)

Setting	Square	Centrex	Hybrid	PBX	DID		
Filter 00	No restrictions (cannot be changed)						
Filter 01	Same as those for the Square template						
Restr'n 01						0	90
Restr'n 02						1	91
Except'ns						1800	91800
						1555	91555
						1*1*555	91*1*555
						1*0*555	91*0*555
Restr'n 03	911	9911					
Except'ns	911	9911					
Restr'n 04	411	9411					
Restr'n 05	976	9976					
Filter 02 to 99	No restrictions						

Remote access packages (Capabilities)

Setting	Square	Centrex	Hybrid	PBX	DID
Package 00	Prohibits access to line pools and remote Page. Cannot be changed.				
Package 01	Yes for Pool A No for Pools B to O				
Line pool access					
Remote page					
Packages 02 - 15	No for Pools A to O				
Line pool access					
Remote page					

Set abilities (Capabilities)

Setting	Square	Centrex	Hybrid	PBX	DID
Set filter	Normal	02			
	Mode 1	11			
	Mode 2	12			
	Mode 3	13			
	Mode 4	00			
	Mode 5	00			
	Mode 6	00			
Line/set filter	Normal and Modes 1 - 6		None		
Set lock	None				
Full handsfree	No				
Auto handsfree	No				
HF answerback	Yes				
Pickup group	No				
Paging	Yes				
Page zone	1				
Aux. ringer	No				
Direct-dial	Set1				
Forward on busy	None				
Forward no answer	None				
Forward delay	3 rings				
Allow redirect	No				
Redirect ring	Yes				
Hotline	None				
Use	Prime line				
Priority call	No				

Service Modes

Setting	Square	Centrex	Hybrid	PBX	DID
Mode names	Mode 1 Mode 2 Mode 3 Mode 4 Mode 5 Mode 6	Night Evening Lunch Mode 4 Mode 5 Mode 6			
Mode times	Day Mode 1 Mode 2 Mode 3 Mode 4 Mode 5 Mode 6	All days Start 23:00 17:00 12:00 00:00 00:00 00:00	Stop 7:00 23:00 13:00 00:00 00:00 00:00		
Control sets	All lines All sets	Set 221 Set 221			
Ringling service	All modes Trunk answer Extra-dial For all lines: Ringing sets Aux. ringer	Off Yes Set 221 Set 221 Yes			
Restriction service	All modes	Off			
Routing service	All modes Overflow	Off No			

Passwords

Setting	Default
Admin password	A D M I N OR 2 3 6 4 6

Log Defaults

Setting	Square	Centrex	Hybrid	PBX	DID
Space/Log	0				

Call Services

Setting	Square	Centrex	Hybrid	PBX	DID
Auto Call Info	None				Lines 001to 120: None Lines 121-248: Set at which target line appears
Set services Autolog/Show Vmsg Logging set	No				Lines 001to 120: N Lines 121-248: Y for set to which target line is assigned
Show extl Vmsg	No				
Log space Log Pool	0 600				
Log passwrd	None				
1stDisplay	Name				
VMsg center tel#s	Centers 1 - 5	No number stored			
VMsg tel#s lines	1 for all lines				

Startup programming

After the hardware has been installed and powered up, use Startup to initialize the system, and select one of the five system templates.

	Startup erases programming
	<p>Startup erases any existing programmed data, and resets the system to factory defaults.</p>

Performing Startup

1. Enter the Startup access code from a Norstar M7310 or M7324 telephone dial pad, by pressing

Feature * * S T A R T U P which is the same as
 Feature * * 7 8 2 7 8 8 7 .

To be accepted, the Startup code must be entered no later than 15 minutes after the Norstar system has been powered up. (If 15 minutes have elapsed since you powered up the system, turn system power off and on, to prepare for the Startup process.)

2. Enter the Installer password. The default is C O N F I G which is the same as 2 6 6 3 4 4 .

Tips

The Installer password shown is the default normally used for Startup. For a system which has already been programmed, the Installer password might have been changed in Configuration and recorded in the *Programming Record*.

Changing the default template

After entering the Startup access code and Installer password the display reads **Reset memory?**.

1. Press YES to select a default template. The display shows the current template.

2. Press **CHANGE** to choose one of five templates (Square, Centrex, Hybrid, PBX or DID).

	<p style="text-align: center;">Changing template resets system programming</p> <p>If you change your system template, your Configuration and Administration programming will be reset.</p>
---	---

Changing the starting DN number

You can change the starting number for your telephone directory numbers (DNs). This is helpful when your system is part of a network and you want to use a uniform series of directory numbers for all telephones in your network.

With the display showing the current template.

1. Press . The display shows the current start DN.
2. Press **CHANGE**.
3. Enter the new directory number you want as the starting DN and press **OK**. The display shows the new range of DN numbers.
4. Press to store the programming. The display reads **Template applied**. The indicators begin to flash after a few moments, then the display reads **Jan 1 1:00 am**.

Tips

All Configuration and Administration programming is retained for three days if the power fails or if the Norstar system is powered off. After three days without power, it may be necessary to perform Startup.

The length of the new DN can be from two to seven digits on a non-expanded system and from three to seven digits on an expanded system.

The length of the directory number that you enter sets the length for all directory numbers and target line received numbers in the system.

A DN length change, if required, should be the first programming change on a newly installed Norstar system.

If any future expansion is planned, the DN length should be set to three, even on non-expanded systems.

If you reduce the length of the directory numbers in **6. System Data** in Configuration programming, the starting DN number is reset to the default value (**221**).

If you increase the length of directory numbers in **6. System Data** in Configuration programming, each increase in length places the digit 2 in front of any existing DN. For example, if DN 3444 was increased to a length of 6, the new DN would be 223444.

If the new DNs clash with the direct-dial digit, park prefix, or line pool codes or destination codes, those numbers are overridden and set to None.

Do not disable or enable ports in Maintenance programming during the first two minutes after Startup programming.

Maintenance programming

If your system includes Digital Trunk Interfaces (DTI), you need to perform some Maintenance programming after Startup before you can use your T1 trunks.

1. Press * * which is the same as * * . The display reads **Password:**.
2. Enter the Installer password. The default password is **CONFIG** (266344). The display reads **A. Configuration**. Three triangular indicators ► appear on the vertical display between the rows of buttons.
3. Place the programming overlay over the buttons pointed to by the indicators ►.
4. Press until the display reads **D. Maintenance**.

Choosing the clock source for your DTIs

Systems with digital interfaces need to synchronize to the network in order to function. Synchronization is done in a hierarchical way, where each device/switch obtains the network clock from the device/switch above it in the synchronization hierarchy and passes the network clock to the device/switch below it in the synchronization hierarchy. The synchronization levels are referred to as strata.

Norstar systems are stratum 4E equipment and are usually used as termination points in a network.

7. Clock Source lets you designate which of the systems DTIs obtains the timing reference from the network, which the system synchronizes to. For each DTI, choose one of the following settings:

Primary reference - the DTI obtains the timing reference from the network, which the system synchronizes to. This is the default value for the DTI in slot D1 in the KSU.

Secondary reference - the DTI acts as a standby reference. If there are excessive errors on the primary reference T1 link, or the DTI designated as primary reference fails, this DTI will obtain the timing reference from the network, which the system synchronizes to. This is the default value for the DTI in slot D2 in the KSU.

Timing master - the DTI does not obtain timing from the network, but transmits the systems timing to equipment connected to it.

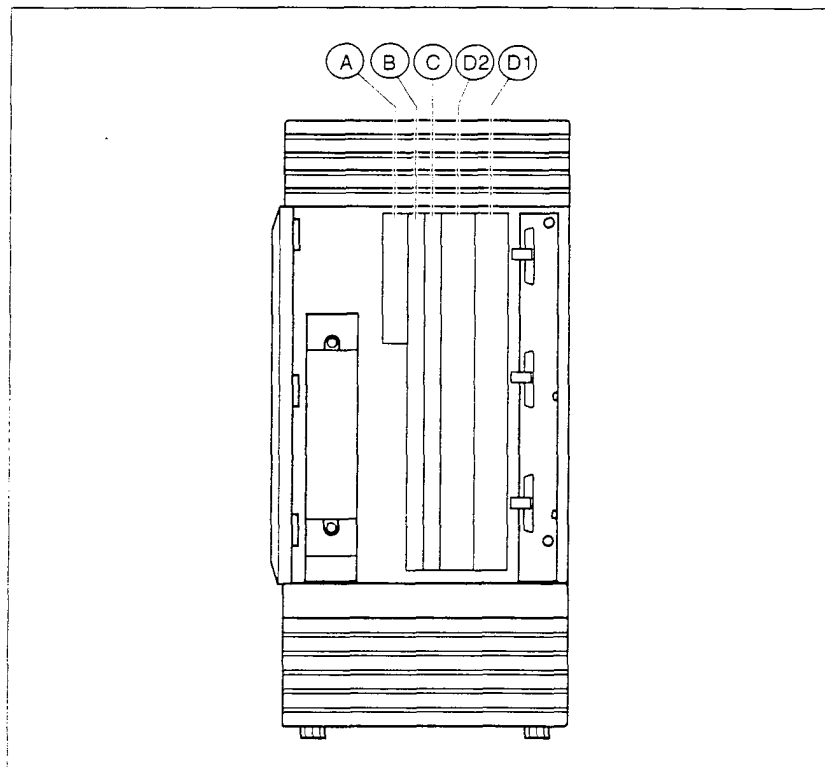

	<p>Changing the clock source may restart system</p> <p>Changing the clock source for your system may cause your system to restart itself. Do not change the clock source during normal business hours since calls may be dropped.</p>
---	--

Begin with the display reading **D. Maintenance**.

1. Press .
2. Press until the display reads **7. Clock Source**.
3. Press . The display shows the clock source setting for the first DTI (slot D1).
4. Press **CHANGE** to toggle the setting.
5. Press to change the setting for the second DTI (slot D2).
6. Press to exit or to continue in Maintenance.

Tips

See Clock Source in the Maintenance chapter for more detail, and for some sample network/clock source configurations.

In most T1 network configurations, you need one DTI in your KSU to act as a primary reference.

If your Norstar system has two DTIs, you cannot assign both DTIs as primary reference or both DTIs as secondary reference. You can only have one primary reference and one secondary reference per system.

Provisioning your T1 lines

Although your DTI is capable of providing 24 T1 lines, not all 24 lines may be in service. You may have only leased a portion of the lines from your telephone company. You should provision the lines you have leased, and deprovision any lines not in use. The default value for a line is **provisioned**.

Begin with the display reading **D. Maintenance**.

1. Press .
2. Press until the display reads **8.Provisioning**.
3. Press .
4. Enter the number of the T1 line you want to provision or deprovision. The display shows the current status of the line.
5. To provision a line, press ADD. To deprovision a line, press REMOVE.
6. Press to move to the next line.
7. Press

Configuration programming

After performing Startup, use Configuration programming to change default settings as required. Default settings for the Square template are shown in bold.

Headings and subheadings in Configuration programming help you to keep track of where you are.

Configuration programming has five headings:

- | | |
|-------------------------|--|
| 1. Trk/Line Data | lets you assign settings to each trunk, external line and incoming target line. |
| 2. Line Access | lets you assign settings to each telephone. |
| 3. Routing | lets you create up to 200 routes and destination codes to provide uniform dialing in a network, and least cost routing. |
| 4. Call Handling | lets you assign system-wide settings associated with various call features. |
| 5. Miscellaneous | lets you assign various system-wide settings. |
| 6. System Data | lets you change a telephone's internal number, the length of all internal numbers, and the number of digits received for target lines, the DISA DN or the Auto DN. |

Entering Configuration

- Press **Feature** ***** ***** **C** **O** **N** **F** **I** **G** which is the same as **Feature** ***** ***** **2** **6** **6** **3** **4** **4**. The display reads **Password:**.
- Enter the Installer password. The default password is **CONFIG** (266344). The display reads **A. Configuration**. Three triangular indicators **▶** appear on the vertical display between the rows of buttons.
- Place the programming overlay over the buttons pointed to by the indicators **▶**.

Trk/Line Data is broken into three main tasks or sections. The first task is to configure the Trunk Cartridges in the KSU and Trunk Modules. Trunk data lets you program settings for lines that affect how Norstar communicates with other switches. Line data lets you determine how a line will be used in the Norstar system.

Tips

Several of the settings in **1. Trk/Line Data** cannot be changed unless you disable the affected Trunk Cartridges first.

For a new installation, there are two ways you can proceed:

1. Pre-program the Feature Cartridge on a system that has no Trunk Cartridges installed. This lets you freely change all the settings in **1. Trk/Line Data**. Install your Trunk Cartridges once you have completed programming.
2. If you are programming a new system with Trunk Cartridges already installed, enter Maintenance and disable all the Trunk Cartridges using **3. Module Status** before you begin **1. Trk/Line Data** programming. When you complete **1. Trk/Line Data** programming, re-enter Maintenance and enable all the Trunk Cartridges.

For an existing installation:

1. Enter Maintenance and disable the affected Trunk Cartridges before proceeding with **1. Trk/Line Data** programming. Re-enable the cartridges once you have finished.

Copying Trunk and Line data

At the **Show Line:** _ display **COPY** appears. This allows you to copy programming from one line to other lines.

Tips

In copying data from a physical trunk to a target line (or the other way around), only the data in common is copied. For example, copying a target line to an E&M trunk copies only the Line data settings because there are no Trunk data settings for a target line.

If you try to copy line programming between lines on different types of Trunk Cartridges, the display reads **Incompatible TC**, then returns to **Show line: _**. You cannot copy programming between lines on different types of Trunk Cartridges.

The Received number of a target line is a unique number and cannot be copied.

TCs on

The TCs on setting lets you specify the set of Trunk Cartridges you want to configure. Press CHANGE to select the setting: **KSU**, TM3, TM4, TM5, TM6, TM7, TM8.

Tips

Trunk Modules are numbered 3 to 8. The first Trunk Module connected to the six-port Expansion Cartridge (plugged into the top fiber connector) is TM8. The first Trunk Module connected to the two-port Expansion Cartridge (plugged into the top fiber connector) is TM4.

TC1 on KSU

The TC on KSU setting allows you to specify the type of Trunk Cartridges in the KSU. Press CHANGE to select the setting: **Loop** or T1.

Loop is the default setting used for Loop Start and Call Information (CI) Trunk Cartridges.

Select the T1 setting for DTIs.

Tips

You cannot change this setting unless you first disable the Trunk Cartridge using **3. Module Status** in Maintenance. Remember to enable the Trunk Cartridge once you have completed programming. See the Maintenance chapter for details.

The Trunk Cartridge slots in the KSU are numbered from right to left.

Lines 001-004

Once you specify the type of Trunk Cartridge in the KSU slot, press **SHOW** to display the line numbered range for the lines on the Trunk Cartridge.

	Line numbers for Loop start	Line numbers for T1
TC1 on KSU	001-004	001-024
TC2 on KSU	025-028	025-048

TC1 on TM3

The TC on TM setting allows you to specify the type of Trunk Cartridges in the Trunk Module. Press **CHANGE** to select the setting: **Loop**, **E&M**, or **DID**.

Loop is the default setting used for Loop start and Call Information (CI) Trunk Cartridges.

Tips

You cannot change this setting unless you first disable the Trunk Cartridge using **3. Module Status** in Maintenance. Remember to enable the Trunk Cartridge once you have completed programming. See the Maintenance chapter for details.

The Trunk Cartridge slots in the TM are numbered from left to right.

Trunk Modules are numbered 3 to 8. The first Trunk Module connected to the Expansion Cartridge (plugged into the top fiber connector) is TM8.

Lines 049-052

Once you specify the type of Trunk Cartridge in the KSU slot, press SHOW to display the line numbered range for the lines on the Trunk Cartridge.

TCs	Line numbers for six-port Expansion Cartridge	Line numbers for two-port Expansion Cartridge
TC1 on TM3	109-112	061-064
TC2 on TM3	113-116	065-068
TC3 on TM3	117-120	069-072
TC1 on TM4	097-100	049-052
TC2 on TM4	101-104	053-056
TC3 on TM4	105-108	057-060
TC1 on TM5	085-088	
TC2 on TM5	089-092	
TC3 on TM5	093-096	
TC1 on TM6	073-076	
TC2 on TM6	077-080	
TC3 on TM6	081-084	
TC1 on TM7	061-064	
TC2 on TM7	065-068	
TC3 on TM7	069-072	
TC1 on TM8	049-052	
TC2 on TM8	053-056	
TC3 on TM8	057-060	

Discon timer

Disconnect timer allows you to specify the duration of an Open Switch Interval (OSI) before the Disconnect (or loop) a call on a supervised external line is considered disconnected. Press CHANGE to select the setting: 60, 100, 260, **460**, or 600 milliseconds.

Tips

Disconnect Supervision is assigned to each line with the Trunk mode setting in the Trunk data section of Configuration programming.

This setting must match the setting for the line at the central office.

This setting only appears for DTI and Loop Trunk Cartridges.

Answer timer

Answer timer allows you to set the minimum duration of an answer signal before a call is considered to be answered. Press CHANGE to select the setting: 1, 2, 3, 4 or 5 seconds.

Tips

This setting only appears for DTI and E&M Trunk Cartridges.

CO fail

Select the carrier failure standard used by your T1 service provider. Press CHANGE to select the setting: **TIA-547A** or TR64211.

Tips

This setting only appears for DTIs. Consult your T1 service provider for the proper setting.

Framing

Framing lets you select the framing format used by your T1 service provider. Press CHANGE to select the setting: **ESF** (Extended Superframe) or SF (Superframe).

Tips

This setting only appears for DTIs. Consult your T1 service provider for the proper setting.

You must disable the Trunk Cartridge using **3.Module Status** in Maintenance before you can change this setting. See the Maintenance chapter for details.

SF or Superframe is sometimes known as D4.

Internal CSU

Internal CSU allows you to turn the internal T1 channel service unit on or off. The channel service unit gathers performance statistics for your T1 lines. Press CHANGE to select the setting: **ON** or **OFF**.

Tips

This setting only appears for DTIs.

You must disable the Trunk Cartridge using **3. Module Status** in Maintenance before you can change this setting. See the Maintenance chapter for details.

You can view the performance statistics for your T1 lines in Maintenance under the heading **10. CSU Stats**.

If you set the internal CSU off, there must be an external CSU connected to your T1 lines.

CSU line bld

CSU line build allows you to set the gain level of the transmitted signal. Press CHANGE to select the setting: **0**, **7.5** or **15 dB**.

Tips

This setting only appears for DTIs that have their internal CSU turned on.

You must disable the Trunk Cartridge using **3. Module Status** in Maintenance before you can change this setting. See the Maintenance chapter for details.

DSX1 bld

DSX1 build out allows you to set the distance between the KSU and an external channel service unit. Press CHANGE to select the setting: **000-100**, **100-200**, **200-300**, **300-400**, **400-500**, **500-600**, **600-700** feet.

Tips

This setting only appears for DTIs that have their internal CSU turned off.

You must disable the Trunk Cartridge using **3. Module Status** in Maintenance before you can change this setting. See the Maintenance chapter for details.

Line coding

Select the standard used by your T1 service provider for encoding signals on the T1 lines. Press **CHANGE** to select the setting: **B8ZS** or **AMI**.

Tips

This setting only appears for DTIs. Consult your T1 service provider for the proper setting.

You must disable the Trunk Cartridge using **3. Module Status** in Maintenance before you can change this setting. See the Maintenance chapter for details.

	Enable Trunk Cartridges
	If you have disabled any Trunk Cartridges to perform Configuration programming, enable them now using 3. Module Status in Maintenance or your system will not function properly. See the Maintenance chapter for information on enabling Trunk Cartridges in Module Status.

Trunk data

Some Trunk Data settings may not appear on the display during programming depending on the type of trunk. Those that appear for a given Trunk type are indicated in the following table.

Trunk data settings that appear for a given trunk type

Setting	Loop start	E&M	DID	Target lines
Line<nnn>:	√	√	√	—
Trunk mode	√	—	—	—
Ans mode	√	√	—	—
Ans with DISA	√	√	—	—
Signal	—	√	√	—
ANI Number	—	√	√	—
DNIS Number	—	√	—	—
Gain	—	√	—	—
Dial mode	√	√	√	—
Full AutoHold	√	—	—	—
LossPkg	√	—	—	—
Rec'd #	—	—	—	√

Line<nnn>

The Line setting shows the trunk type for a line. For lines connected to a DTI, press CHANGE to select the setting: **Loop**, E&M or DID.

- Loop is the default setting used for loop start trunks.
- E&M is for the first two line numbers on E&M trunks.
- DID is for direct inward dialing (DID) trunks.

Tips

You can only change this setting for lines connected to a DTI. For all other lines, the trunk type is determined by the Trunk Cartridge type. The system simply displays the trunk type; you cannot change it.

E&M Trunk Cartridges have two E&M lines and two DTMF receivers (instead of four lines as in a Loop Start Trunk Cartridge). For example, if an E&M Trunk Cartridge has the range of line numbers 049 to 052, numbers 049 and 050 are E&M lines, and numbers 051 and 052 are the DTMF receivers. The display for line 050 appears as **Line050:E&M** and for line 051 appears as **Line051:DTMF**.

Changing the settings for trunk type (that is, Loop Start, E&M or DID) on a system that is in use, may cause calls to be dropped.

Trunk mode

Trunk mode lets you specify one of two modes of operation for each line: disconnect supervision or unsupervised. Disconnect supervision, also referred to as loop supervision, releases an external line when an open switch interval (OSI) is detected during a call on that line. This prevents the line from remaining unavailable for other Norstar users.

Press **CHANGE** to select the setting: **Unspr** or **Super**.

- **Unspr** (the default) turns disconnect supervision off for the line.
- **Super** assigns supervised mode, if supported by the line; otherwise, the line functions as unsupervised.

Tips

The Trunk mode setting is used only for lines on a Loop Start or CI Trunk Cartridge, and for loop start lines connected to a DTI.

The duration of an OSI before Norstar disconnects a call is programmed by the Discon timer setting of **1**. **Trk/Line Data** programming.

Disconnect supervision is required for loop start trunks to operate in auto-answer mode or with DISA.

The line must be equipped with disconnect supervision from the central office for the Super option to work.

Ans mode

The Answer mode setting appears on the display during programming for loop start lines if the Trunk mode setting was Super, and for E&M lines. Press **CHANGE** to select the setting: **Manual** or Auto.

Tips

Remember that disconnect supervision is required if loop start trunks are to operate in auto-answer mode.

You should change the Answer with DISA setting to N, for E&M trunks in a private network operating in auto-answer mode. The default, Y (Yes), causes the system to expect a Class of Service password after it automatically answers a trunk.

Ans with DISA

When activated, the Answer with DISA setting specifies that a trunk is answered with stutter dial tone. Press **CHANGE** to select the setting: Y (Yes) or N (No).

Tips

For loop start and E&M lines this setting only appears if Answer mode is Auto.

Set Ans with DISA to No for E&M lines on an enhanced switched network (ESN) to operate properly in auto-answer mode.

Signal

Select the signal type for the line. Press **CHANGE** to select the setting: **WinkStart**, Immediate and DelayDial.

Tips

The Signal setting appears on the display only for E&M or DID lines.

Make sure that this matches the signal type programmed for the trunk at the other switch.

For E&M and DID lines connected to a DTI, the Immediate setting does not appear if dial mode for the line is tone.

ANI Number

Select whether the telephone number of the caller will be collected for this line. The digits can then be displayed on Norstar telephones as part of Call Display services. Press CHANGE to select the setting: **N** (No) or **Y** (Yes).

Tips

This setting applies only to E&M and DID lines.

For E&M or DID lines connected to a DTI, this setting only appears if Signal is WinkStart.

For lines connected to an E&M or DID Trunk Cartridge, this setting only appears if Signal is WinkStart or Immediate.

No additional equipment is required.

DNIS Number

Select whether the digits dialed by an external caller on this line will be collected. Press CHANGE to select the setting: **N** (No) or **Y** (Yes).

Tips

This setting applies to E&M lines only.

For E&M lines connected to a DTI, this setting only appears if Signal is WinkStart and Ans mode is Manual. For E&M lines connected to an E&M Trunk Cartridge, this setting only appears if Signal is WinkStart or Immediate and Ans mode is Manual.

These digits are required for some third party software applications.

Gain

Select the appropriate gain level for the line. Press CHANGE to select the setting: **Normal** or **High**.

The default value **Normal** induces zero loss. Use it when the E&M trunks are connected to facilities that present 0 dBm at the interface, for both the transmit and receive paths.

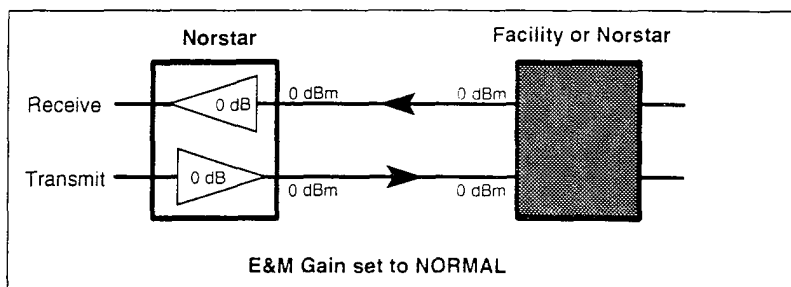

The value **High** induces 7 dB of loss in the receive path and 16 dB of loss in the transmit path. Use it when the E&M trunks are connected to facilities that present +7 dBm in the receive path, and -16 dBm in the transmit path, at the interface.

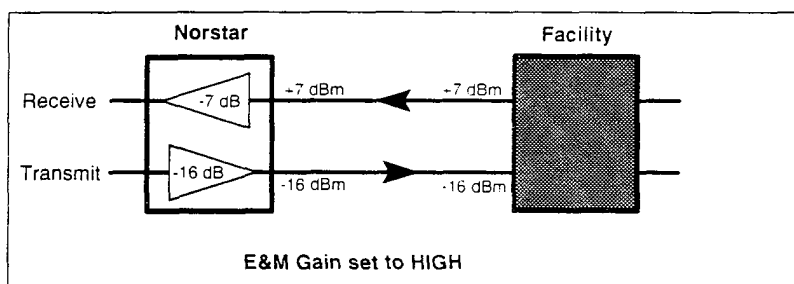

Tips

Control over the gain (transmission levels) can only be set for lines on E&M Trunk Cartridges.

Dial mode

Dial mode lets you specify whether dual tone multifrequency (DTMF) or pulse signalling is used on the trunk. Press **CHANGE** to select the setting: **Pulse** or **Tone**.

Tips

For DID and E&M lines connected to a DTI, the **Tone** setting does not appear if **Signal** is **Immediate**.

Full AutoHold

Full AutoHold on idle line is a variation of the Automatic Hold feature. If you select an idle line, but do not dial any digits, that line is automatically placed on hold if you then select another line. Press **CHANGE** to select the setting: **N** (No) or **Y** (Yes).

The line you first selected is held until you press its button. The line is not available for use by anyone else.

Tips

The Full AutoHold setting appears only during loop start trunk programming. Full AutoHold is always in place for E&M trunks; it has no meaning for incoming-only DID trunks.

The default setting should be changed only if Full AutoHold is required for a specific application.

LossPkg

Loss Package lets you select the appropriate loss/gain and impedance settings for each line. The setting is based on the distance between the KSU and the terminating switch, and the terminating switch type. The following table shows the available settings.

LossPkg	Receive Loss	Transmit Loss	Impedance	Distance to switch/cable loss/terminating switch
ShortCO	0 dB	3 dB	Short	Short/<2 dB/KSU to CO
MediumCO	0 dB	0 dB	TIA/EIA 464	Medium/>2 dB and <6 dB/KSU to CO
LongCO	-3 dB	0 dB	TIA/EIA 464	Long/>6 dB/KSU to CO
ShortPBX	0 dB	0 dB	Short	Short/<2 dB/KSU to PBX
LongPBX	-3 dB	0 dB	TIA/EIA 464	Long/>2 dB/KSU to PBX

A loss of 4 dB corresponds to a cable length of approx. 2700 m (9000 ft).

Press **CHANGE** to select the setting: ShortCO, **MediumCO**, LongCO, ShortPBX or LongPBX.

Tips

This setting applies only to lines connected to an NT7B75GA-93 Loop Start Trunk Cartridge.

Rec'd #

The Received number setting applies only to target lines (line numbers 121 to 248). It allows you to specify the digits which make a specific target line ring. The default value is **None**.

Use **CHANGE**, and the dial pad to program the digit string for each target line.

Tips

A Received number can be two to seven digits long (programmed in **6. System Data**). The default length for a non-expanded system is 2. The default length for an expanded system is 3.

A received number cannot be the same as, or be the start digits of a line pool access code, a destination code, the DISA DN or the Auto DN.

Line data

Line data programming can be applied to all lines, trunks (001 - 120) and target lines (121 - 248).

Line type

This setting specifies how the line is to be used in relation to other lines in the system. Press **CHANGE** to select the setting: **Public**, **Private to:**, or **Pool (A to O**, representing 15 line pools).

- A **Public** line can be accessed by more than one telephone.
- A **Private** line can be assigned only to one telephone and the prime telephone for that line. Use **CHANGE** and the dial pad to enter the internal number of the telephone.
- **Pool** assigns the line to one of the fifteen line pools. If a line is assigned to a line pool, but is not assigned to any telephone, that line is available only for outgoing calls.

Tips

Line pools must never contain a mixture of loop start lines and E&M lines.

All E&M lines in a given line pool should go to the same location.

Try to avoid putting unsupervised loopstart lines in a line pool. These lines can become hung, especially when a remote user uses the line pool to make an external call.

There are two more programming settings that must be assigned before a line pool can be used:

- You must assign line pool access to telephones in the **2. Line Access** section of Configuration programming.
- You must assign system-wide line pool access codes in the Miscellaneous section of Configuration programming.

A telephone can be administered to search automatically for an idle line from several lines appearing on the telephone. Assign a line pool as the prime line (in **2. Line Access**) and all the lines in the line pool must appear on that telephone. When the user lifts the receiver or presses , any one of the lines, if idle, can be selected by Automatic Outgoing Line selection.

When assigning lines to line pools, consider your network configuration. You may be able to create a unified dialing plan by assigning lines to the same location to the same line pool on each of your systems. For example, if system A and system B each have tie lines to system C, assign the tie lines to pool D on each of the systems.

If you plan to program the prime line as I/C (intercom) for some telephones, you may wish to assign loop start lines to the first line pool. Remember that when the system searches for an outgoing line, it begins at line pool A and chooses the first available line.

Assigning a single E&M trunk to a line pool allows features like Ring Again to help manage access to a shared resource.

You cannot assign target lines (121-248) to a line pool.

Line grp

Select whether this line will be part of an incoming line group. An incoming line group is a group of lines used only for receiving incoming calls. This allows a group of incoming lines to appear and/or ring at only one button on a telephone. Press **CHANGE** to select the setting: **None** or ILG (01 to 15, representing 15 incoming line groups).

Tips

Do not assign auto-answer loop start or E&M lines, or DID lines to an incoming line group.

An incoming line group must be assigned to appear at a telephone.

Whether a line in an incoming line group rings at a telephone depends on the ringing setting for the line the call is on. If an incoming line group contains a mix of ringing and non-ringing lines, it will ring for some calls and not for others.

If you answer a call on an incoming line group, and a second call comes in on the same group, your telephone rings softly. However, you cannot answer the second call without ending the first.

You cannot make a call using an incoming line group.

Note the difference between incoming line groups and line pools. An incoming line group is a collection of lines used only for incoming calls. A line pool is a collection of lines used only for making outgoing calls. These groupings are for convenience in making and answering calls; they do not limit how the lines themselves can be used. A line may appear in a line pool, an incoming line group, and individually on telephones at the same time. However, you can not place a line in more than one incoming line group or line pool.

You can place a call in an incoming line group on hold and retrieve it in the normal way. However, a held ILG call cannot be picked up at any other telephone unless the line is assigned to appear at that telephone.

Prime set

This feature allows you to assign a telephone to provide backup answering for calls on the line. Unanswered calls are redirected to the prime telephone. Use **CHANGE** and the dial pad to enter the internal number of the prime telephone.

Tips

For auto-answer trunks, calls ring only at the prime telephone for a trunk, and only when overflow call routing is active.

Each line can be assigned only one prime telephone.

Aux. ringer

This setting allows you to turn the auxiliary ringer on or off. When turned on, the auxiliary ringer rings for any incoming calls that ring on the line. The auxiliary ringer is an optional device that must be connected by the installer. Press **CHANGE** to select the setting: Y (Yes) and N (No).

Tips

An auxiliary ringer can be programmed, in the Service Modes section of Administration programming, to ring for a line placed into a Service Mode. An auxiliary ringer can also be programmed to ring for calls to a telephone. See the *System Coordinator Guide* for more information.

If you have an auxiliary ringer programmed to ring for calls on an external line, and you transfer a call on that line without announcing the transfer, the auxiliary ringer will ring for the call transfer.

Auto privacy

This feature controls whether one Norstar user can select a line in use at another telephone to join an existing call. The default setting is Privacy on, so that nobody with a Norstar telephone can press a line appearance on their telephone to join a call in progress at another telephone. Press **CHANGE** to select the setting: Y (on) and N (off).

Tips

Users can change a line's privacy setting for an individual call using the Privacy feature (**Feature**).

Line Access

Line Access allows you to assign lines to individual telephones. When you are finished programming Line Access settings for one telephone, you can copy those settings to other telephones.

2. Line Access	
Show set: _	
Line assignment	
Show line: _	
Line001	Appear&Ring
ILG assignment	
Show ILG: _	
LG01	Notassignd
Answer DNs	
Show set: _	
	Notassignd
Line pool access	
Line pool A	N
Intercom keys	2
Prime line	None

Line assignment

This setting allows you to assign physical trunks and target lines to each telephone. Target lines are assigned and removed in the same manner as other lines. Press and enter the line number. Press **CHANGE** to change the setting for each line: **Appear&Ring**, **Appear only**, **Not assignd**, or **Ring only**.

Tips

Press **SCAN** to view the lines assigned to this telephone.

The default line assignments depend on the system template assigned during Startup programming. The default line assignment for the Square template has lines 001 and 002 appear and ring at all telephones.

130 / Line Access

In general, auto-answer loop start trunks, auto-answer E&M trunks and DID trunks are not assigned to telephones. If assigned, they are used for monitoring incoming call usage, or for making outgoing calls (auto-answer loop start and E&M trunks).

You cannot assign a line that is private to another telephone.

Each line assigned to appear at a telephone must appear at a button with an indicator on that telephone. The maximum number of line buttons are: 8 for the M7208 telephone; 10 for the M7310 telephone; 24 for the M7324 telephone.

If you set a line to Ring only, incoming calls appear on an intercom button.

A central answering position (CAP), with one or two CAP modules, can provide extra line buttons if more than 24 lines are assigned to the CAP. The remaining lines appear at buttons on the CAP module.

The M7100 telephone is an exception; it has no line buttons and can be assigned any number of lines.

Make sure that lines assigned to an M7100 telephone are assigned to ring; otherwise, you cannot detect incoming calls on the lines.

ILG assignment

The Incoming Line Group assignment setting lets you assign incoming line groups to individual telephones. Press enter the ILG number (01-15). Press **CHANGE** to change the setting: **Not assigned**, assigned.

Tips

Press **SCAN** to view the ILGs assigned to this telephone.

If you want incoming calls on an line in an incoming line group to ring at a telephone, assign the individual line to Ring only in Line assignment.

You cannot assign an incoming line group to an M7100 telephone or to an Analog Terminal Adaptor.

Answer DNs

Calls for other Norstar telephones can appear and be answered at the telephone being programmed. The DNs of the other telephones are referred to as Answer DNs. You can assign up to four Answer DNs to the telephone being programmed. Press and enter the Answer DN. Press **CHANGE** to change the setting for the Answer DN: **Appear&Ring**, **Appear only**, or **Not assignd**.

To assign additional Answer DNs, press , then enter the next Answer DN.

Tips

Press **SCAN** to view the Answer DNs assigned to this telephone.

Every Answer DN assigned to the telephone automatically assigns an Answer button with an indicator to the telephone. These buttons should be labeled accordingly, identifying the telephone with its name or DN.

More than one telephone can have an Answer button for the same DN. In this way, more than one telephone can provide call alerting and call answering for any calls directed to that DN.

A private line does not generate alerting at an Answer button.

You cannot assign Answer DNs to an M7100 telephone or to a single-line telephone connected to an ATA.

Line pool access

This setting allows a telephone to access one or more of the fifteen line pools available (A to O). When you assign "yes" for a given line pool, the telephone being programmed can access any lines in that line pool.

Press and to display the line pool you want to program access to. Press **CHANGE** to select the setting: **N** (No) and **Y** (Yes).

Intercom keys

This setting assigns the number of intercom buttons to a telephone. Intercom buttons provide a telephone with access to internal lines and line pools. Press **CHANGE** to select the setting: 0, 1, 2, 3, 4, 5, 6, 7, or 8.

Tips

Each intercom button assigned during programming automatically appears on the telephone. The buttons start with the lower right-hand button, or one button above if the Handsfree/Mute feature is assigned to the telephone.

A telephone needs two intercom buttons to be able to establish a conference call with two other Norstar telephones.

Only one intercom button may be required if the button will only be used to make and receive internal calls, and to access line pools.

Two intercom buttons are required if a telephone has several lines assigned to ring only.

The M7100 telephone default assignment of two Intercom buttons cannot be changed. These buttons do not appear on the telephone.

Prime line

This setting assigns a prime line to the telephone. A prime line is the first line that is automatically selected when a call is made from a Norstar telephone. Press **CHANGE** to select the setting: **None**, a line number, Pool (A to O), and I/C (intercom). (Only assigned lines and line pools appear.)

Tips

An assigned prime line is not associated with the assignment of a prime telephone.

An external line must be assigned to the telephone in Line assignment before it can be assigned as the prime line to the telephone.

A line pool must be assigned to the telephone in line pool access before a line pool can be assigned as the prime line to the telephone.

A target line cannot be a prime line for a telephone because it is incoming-only.

A DID line should not be assigned as the prime line for a telephone. If assigned, it is treated as if no prime line has been assigned. The message **Select a line** appears when the receiver is lifted.

Remember that if you set prime line to I/C (intercom), you may wish to assign loop start lines to the first line pools. Remember that when the system searches for an outgoing line, it begins at line pool A and chooses the first available line.

By assigning a line pool as a prime line, a telephone can be made to search automatically for an idle line in a pool. This is described in the section on programming Line type (1. Trk/Line Data).

Routing

Routing allows you to create tables of up to 200 routes and destination codes to provide uniform dialing in a network. You can also use the tables to alternate routes during different Service Modes to control your telecommunication costs.

3. Routing	
Define routes	
Route: _	
Use	Pool A
DialOut	Max 24 digits
Dest codes	
DestCode: _	
Mode	Normal
Use route	200
Mode	Night
Mode	Evening
Mode	Lunch
Mode	Mode 4
Mode	Mode 5
Mode	Mode 6

When you select an internal line and dial, the numbers you enter are checked against the routing tables. If the number you dialed starts with a destination code, the system uses the line pool and then dials the DialOut digits specified by the route assigned to that destination code, and then dials the rest of the number that you dialed.

Routing tables are used primarily by systems in a network. They allow you to set up uniform dialing for telephones in your network. For example, if the telephones on your Norstar system use extension numbers 221 to 249, and you are connected to another system that has extension numbers 4350 to 4384 using an auto-answer E&M trunk that is in line pool C, you can have the following routing table entries:

Route	Use	DialOut
001	Pool C	43

DestCode	Mode	Use route
3	Normal	001

You could then call extension 4350 on the other system, by dialing 350 in the same way you call other telephones in your Norstar system. The 43 is substituted for the 3, and line pool C is chosen.

If your system is equipped with E&M lines or other special lines that permit less expensive long distance calling, routing tables can also be used to choose the least expensive route for a call. You simply assign different routes to different modes for the same destination code. The modes can be activated manually or automatically by a schedule set up in 6. **Service Modes** in Administration programming.

Tips

If the telephone used to make a network call has an appearance of a line used by the route, the call will move from the intercom button to the line button.

Network calls that use routes are subject to the normal dialing filters in effect.

The telephone used to make a network call must have access to the line pool used by the route.

Network calls are external calls, even though they appear to be dialed as internal calls. Only the features and capabilities allowed for external calls can be used.

Network calls must be programmed as external autodial numbers, even though they appear to be dialed as internal calls.

Define routes

Define routes lets you create a table of routes that you can then assign to particular destination codes. A route is defined as the line pool used and the digits dialed to get from your Norstar system to another switch/destination. Press and enter the number (001-200) of the route you want to create or modify.

Tips

Press SCAN to view defined routes

Press CLEAR to erase a defined route.

Routes generally define the path between your Norstar switch and another switch in your network, not other individual telephones on that switch.

Use

Select the line pool that you want this route to use. Press and CHANGE to select the setting: **Pool A** through Pool 0.

DialOut

Enter any digits that must be dialed out on the line to access the destination. Use CHANGE and the dial pad to enter the digits.

Tips

The DialOut number can be up to 24 digits long. You can include any required host system signaling codes. See the *System Coordinator Guide* for details on host system signaling codes.

VIEW allows you to view DialOut numbers that are more than eight digits long.

Dest codes

Dest codes lets you create a table that specifies which digit sequences the system captures and translates using the defined routes when someone in your system makes an internal call. Press to view destination codes. Press **ADD** and enter a new destination code, or enter an existing destination code.

Tips

A destination code can be up to 7 digits long.

You can create up to 200 destination codes.

No two destination codes can be identical.

A destination code cannot begin with a digit assigned as the Call Park prefix, or a direct-dial digit. It cannot be the same as, or be the start digits of a DN, the DISA DN or the Auto DN, a line pool code, or a target line received number. There must be at least one digit that is different. For example, if you have a DN of 3221, you can use 3222 as a destination code, but not 32 or 322.

You can find any destination code that uses a particular route by pressing **ROUTE** and entering the route number.

Mode

Mode lets you specify which mode you want to define a route for. Modes allow you to define several routes for the same destination code. In this way, you can use the least expensive route for a destination code at a particular time, by activating a different mode. Modes are activated manually from control telephones, or automatically by a schedule defined in **6. Service Modes** in Administration. Press , and **NEXT** to select the mode: Normal, Night, Evening, Lunch, Mode 4, Mode 5, Mode 6.

Tips

If a name has been programmed for the mode in **6. Service Modes** in Administration, the mode name is displayed.

Consult the *System Coordinator Guide* for information on programming Service Modes.

Use route

Specify the route that you want the destination code to use during the specified mode. Use **CHANGE** and the dial pad to enter the route number.

Tips

If the programmed route is busy when a call is made, the mode may be programmed to overflow to the normal route. If this happens, the caller hears the expensive route warning tone and sees a display indicating that an expensive route will be used. The caller can then release the call to avoid using the normal route.

Call Handling

Call Handling allows you to program system-wide characteristics. These characteristics are not associated with any specific line or telephone.

4. Call Handling	
Held reminder	N
(if HLR=Y) Remind delay	60
DRT to prime	Y
(if DRT=Y) DRT delay	3
Trnsfr callbk	3
Park prefix	1
Park timeout	45
Camp timeout	45
Directd pickup	Y
On hold	Tones

Held reminder

When active, Held Line Reminder reminds you that a call at your telephone is still on hold. You periodically hear two tones from your telephone until you return to the call on hold. Press **CHANGE** to select the setting: N (No) or Y (Yes).

Remind delay

Held Line Reminder delay allows you to choose the number of seconds before the Held Line Reminder feature begins at a telephone that has an external call on hold. Press **CHANGE** to select the setting: 30, **60**, 90, 120, 150, or 180 seconds.

Tips

The Held Line Reminder delay can be programmed only if Held Line Reminder is activated.

DRT to prime

Delayed Ring Transfer automatically forwards unanswered external calls to a prime telephone, after a certain period of time. This helps ensure that no external call goes unanswered. Press **CHANGE** to select the setting: **Y** (Yes) or **N** (No).

Tips

An operational prime telephone must be assigned before this feature can operate. A prime telephone is assigned to one or more external lines in the Line Data section of Configuration programming.

DRT delay

Delayed Ring Transfer delay allows you to specify the number of rings before Delayed Ring Transfer transfers a call to a prime telephone. Press **CHANGE** to select the setting: 1, 2, 3, 4, 6, or 10 rings.

Tips

The Delayed Ring Transfer delay can be programmed only if Delayed Ring Transfer is activated.

You can estimate the delay in seconds if you multiply the number of rings by six.

Trnsfr Callbck

Transfer Callback delay allows you to specify the number of rings before a Callback occurs on a transferred call. Press **CHANGE** to select the setting: 3, 4, 5, 6, or 12 rings.

Tips

You can estimate the delay in seconds if you multiply the number of rings by six.

Park prefix

The Park prefix is the first digit of the call park retrieval code that must be entered to retrieve a parked call. If the Park prefix is set to None, calls cannot be parked. Press **CHANGE** to select the setting: 1 to 9, N (None), or 0.

Tips

The Park prefix cannot be the same as: the Direct-dial digit, the External Line access code, the first digit of a DN, the first digit of a line pool access code, or the first digit of a destination code.

Other programmable settings may affect which numbers appear on the display during programming. Although the numbers 0 to 9 are valid Park prefix settings, some may have been already assigned elsewhere by default or by programming changes. (To avoid a conflict, refer to the table of default settings in the description of External code.)

If DN length is changed, and the changed DNs conflict with the Park prefix, the setting changes to None.

Park timeout

Park timeout delay allows you to assign the number of seconds before a parked call on an external line returns to the originating telephone. Press CHANGE to select the setting: 30, 45, 60, 90, 120, 150, 180, 300, or 600 seconds.

Camp timeout

Camp timeout delay allows you to assign the number of seconds before an unanswered camped call is returned to the telephone which camped the call. Press CHANGE to select the setting: 30, 45, 60, 90, 120, 150, or 180 seconds.

Directd pickup

Directed pickup allows you to answer any calls by specifying the ringing telephone's internal number. Press CHANGE to select the setting: Y (Yes) or N (No).

Tips

Directed pickup is not to be confused with the Call Pickup Group feature in Administration programming, which allows you to answer a call at any telephone within a specific group without specifying the internal number of the ringing telephone.

Like Call Pickup Group, Directed pickup is useful when not all the telephones have been assigned the same lines, but you still want to allow your co-workers to answer a call on any external line from their telephones.

On hold

On hold allows you to choose what a caller hears on an external line when the line has been put on hold. Press **CHANGE** to select the setting: **Tones**, Music, or Silence.

Tones provides a periodic tone.

Music provides any signal from a source such as a radio connected to the K&S.

Silence provides no audio feedback.

Miscellaneous

Miscellaneous allows you to program system-wide characteristics. These characteristics are not associated with any specific line or telephone.

5. Miscellaneous	
Backgrnd music	N
Direct-dial #	0
DISA DN	None
Auto DN	None
Alarm set	221
CAP assignment	
CAP1	None
CAP2	None
CAP3	None
CAP4	None
CAP5	None
Link time	600
Set relocation	N
Host delay	1000
Receiver volume	Use systm volume
External code	9
Line pool codes	
Line pool A	Max.4 digits
Installer pswd.	CONFIG

Backgrnd music

Background Music allows you to listen to music through your telephone speaker. A music source must be connected to the Key Service Unit. Press CHANGE to select the setting: N (No) or Y (Yes).

Direct-dial

Direct-dial digit allows you to dial a single system-wide digit that can be used to call a specific telephone, called a Direct-dial telephone. Press **CHANGE** to select the setting: **0** to **9**, or **N** (None).

Tips

There can be as many as five direct-dial telephones in a system. The direct-dial telephone to which specific telephones connect is assigned in Administration (**4. Direct-Dial** and **5. Capabilities**).

People with common interests should be in the same direct-dial group. For instance, the secretary who can best handle calls or questions for a group could have a telephone assigned as the direct-dial telephone for that group.

Another direct-dial telephone, an extra-dial telephone, can be assigned for each Service Mode in Service Modes programming.

The direct-dial digit cannot be the same as the first digit of a DN, of a line pool access code, the external line access code or the Call Park prefix. It cannot be the first digit of a destination code.

If DN length is changed, and the changed DNs conflict with the direct-dial digit, the setting changes to **N**.

DISA DN

For calls answered with DISA, the system presents a stuttered dial tone to prompt a caller to enter a valid password. The Class of Service (COS) that applies to the call is determined by this COS password.

Once a remote user is on the Norstar system, the DISA DN can be used to change the existing Class of Service.

Use **CHANGE** and the dial pad to enter the digits to be received from the auto-answer trunk. Press to set the DISA DN to None.

Tips

The length of the DISA DN is the same as the Rec'd # length specified in **5. System Data**. The DISA DN is cleared if the Received number length is changed.

The DISA DN cannot be the same as a line pool access code or a destination code.

Auto DN

For calls answered without DISA, no password is required to access the Norstar system. The Class of Service (COS) that applies to the call is determined by the COS for the trunk on which the user is calling. Use **CHANGE** and the dial pad to enter the digits to be received from the auto-answer trunk. Press to set the Auto DN to None.

Tips

The length of the Auto DN is the same as the Rec'd # length specified in **5. System Data**. The Auto DN is cleared if the Received number length is changed.

The Auto DN cannot be the same as a line pool access code or a destination code.

Alarm set

Alarm telephone allows you to assign a telephone on which alarm messages appear when a problem has been detected in the system. Use **CHANGE** and the dial pad to enter the internal number of the Alarm telephone. Press to set the Alarm telephone to None. The default setting is **221**.

CAP assignment

This setting designates a telephone as a central answering position (CAP). The CAP must be an M7324 telephone, and may have one or two CAP modules attached. A maximum of five CAPs can be installed in a Norstar system.

The CAP may be used to:

- monitor the busy/not busy and Do Not Disturb status of Norstar telephones
- answer external calls on up to 120 lines, and extend calls to other Norstar telephones
- send up to 30 messages to other Norstar telephones
- provide up to 96 extra memory buttons for the M7324 telephone

Use , **CHANGE** and the dial pad to enter the internal number of the M7324 telephone to be designated a CAP.

Tips

If CAP modules are attached to an M7324 telephone that has not been programmed as a CAP, then no CAP settings are assigned.

If a CAP module (or modules) is relocated with the M7324 telephone, the settings are retained.

Link time

Link time allows you to specify the duration of a signal required to access a feature through a remote system. Press **CHANGE** to select the setting: 100, 200, 300, 400, 500, **600**, 700, 800, 900, or 1000 milliseconds.

For example, to program external dialing through a Centrex system, which requires a Link time of 400 ms, specify a Link time of 400.

Tips

The Link time required depends on the requirements of the host switching system that must be accessed.

Link is another name for recall or flash.

Set relocation

Telephone relocation allows you to move any telephone to a new location within the Norstar system without losing the directory number, autodial settings, personal speed dial codes, and any Configuration and Administration programming for that telephone. Press **CHANGE** to select the setting: **N** (No) and **Y** (Yes).

Receiver volume

Receiver volume allows you to specify whether the volume level of a receiver or headset will return to the system default level when a call is ended or put on hold, or whether it will remain at the level set at the individual telephone.

Use and CHANGE to select the setting: **Use sys volume** or **Use set volume**.



Tips - *This feature is not available on some older telephones.*

Host delay

Installer password required

Host delay lets you assign the delay between the moment an outgoing line is selected to make an external call (for example, by lifting the receiver off the telephone) and the moment that Norstar sends dialed digits or codes on the line. Press CHANGE to select the setting: 200, 400, 600, 800, **1000**, 1200, 1400, 1600, 1800, or 2000 milliseconds.



Tips - *Host delay is provided to ensure that a dial tone is present before the dialing sequence is sent. Minimizing this delay provides faster access to the requested features.*

External code

External code allows you to assign the external line access code. This code is used to allow M7100 telephones and Analog Terminal Adapters (ATA) to access external lines.

Use **CHANGE** and the dial pad to program the single digit access code. The default access code is **9**.

Tips

The external line access code cannot conflict with: the Park prefix, the direct-dial digit, the first digit of a line pool access code, the first digit of a DN, or the first digit of a destination code.

If DN range, and the changed DNs conflict with the external line access code, the setting changes to None.

Digits assigned by default to Configuration settings

Digit	Use	Heading
0	direct-dial digit	5. Miscellaneous
1	Park prefix	4. Call handling
2	the first digit of B1 DNs	Startup
9	external line access code	5. Miscellaneous
— —	line pool access code (Not assigned by default, but takes precedence over the External Line access code if there is a conflict.)	5. Miscellaneous
— —	destination code	3. Routing

Line pool codes

This setting allows you to assign a line pool access code for each of the fifteen line pools (A to O). These codes are used to specify the line pool you wish to use for making an outgoing external call.

Use , **CHANGE**, the dial pad, and **OK** to program the access code. The default access code is blank.

Tips

The code can be one to four digits in length. Line pool access codes starting with the same digit must be the same length.

A line pool access code can be the same as an external line access code. In this case, the line pool access code takes priority over the external line access code, and a line from the line pool is selected.

A line pool access code cannot conflict with: the Park prefix, the Direct-dial digit; the first digit of any Received number; the first digit of any DN (including the Auto DN or the DISA DN).

To avoid a conflict, refer to the table of default settings in the description of External code.

Installer pswd.

This setting allows you to change the Installer password that allows access to Configuration programming.

Use CHANGE, the dial pad, and OK to program the Installer password.

Record the password in the *Programming Record*.

Tips

You can choose any combination of one to six digits. It is easier to remember the password if the digits spell a word.

Provide this password only to selected personnel to prevent unauthorized access to Configuration programming. The implications of such access may include the rearrangement of line assignments, which could affect the operation of the Norstar system.

The default Installer password is **266344 (CONFIG)**.

System Data

System Data allows you to specify system-wide settings.

6. System Data	
Individual DNs	
<i>Old DN:</i> _	Max. 7 digits
<i>New DN:</i> _	Max. 7 digits
DN length (<i>'2'</i> on non-expanded system)	3
Rec'd-# length	3

Individual DNs

Individual DNs allows you to change the Directory Number (DN) or internal number of a telephone.

	<p>Changing DN locks Configuration session</p> <p>Changing an individual DN locks the Configuration session into the System Data programming mode. When the System Data session ends, re-enter the Configuration access code and the Installer password to continue with other Configuration or General Administration programming.</p> <p>Do not perform Startup again, or all previous programming will be erased.</p>
---	---

Use , the dial pad, and **OK** to identify the DN you want to change. Then, use the dial pad, and **OK** to enter the new DN.

Tips

No DN changes occur until the Configuration session ends.

If the "new DN" already exists for another telephone, that other telephone is given the "old DN".

All DNs must be the same length.

The first digit of a new DN cannot be the same as the first digit of: an external line access code; a line pool access code; the Park prefix; the Direct-dial digit. To avoid a conflict, refer to the table of default settings in the description of External code.

The lowest default DN for a non-expanded system is **21**, and the lowest default DN for an expanded system is **221**.

DN length

This feature allows you to change the number of digits for all internal DNs. The maximum length is seven. The default and minimum length is **3** for an expanded (with Expansion Cartridge) Norstar system, and **2** for a non-expanded Norstar system.

1. Press **CHANGE** to select the setting: **2**, **3**, **4**, **5**, **6**, or **7** for a non-expanded system; or **3**, **4**, **5**, **6**, or **7** for an expanded system ('**2**' is not available for an expanded system).
2. Press to save the new DN length. The display reads **Drop data calls?**.
3. Press **YES** to save the new DN length. **NO** restores the original value.

	<p style="text-align: center;">Data devices will drop calls</p> <p>You must wait for at least two minutes after a system startup before you change the DN length.</p> <p>Data devices drop calls when the DN length is changed. (Data devices use the B2 channel. The M7100, M7208, M7310, and M7324 telephones use the B1 channel. Calls are not dropped for these telephones.)</p> <p>The DN length change is completed within two minutes, depending on the size of the installed Norstar system. System response may briefly slow down during this time. You cannot re-enter Configuration programming during this time. If you enter the Configuration access code, the message In use: SYSTEM appears on the display.</p>
---	--

Tips

A non-expanded system (with a default DN length of 2) is automatically changed to a DN length of 3 after an expansion cartridge is installed and power is restored to the KSU.

If any future expansion is planned, the DN length should be set to three, even on non-expanded systems.

A DN length change, if required, should be the first programming change on a newly installed Norstar system.

Each increase in length places the digit 2 in front of any existing DN. For example, if DN 3444 was increased to a length of 6, the new DN would be 223444.

If the DN length is changed so that a conflict is created with the Park prefix, external line access code, Direct-dial digit, or any line pool access code, the setting for the prefix or code is changed to None, and the corresponding feature is disabled.

Rec'd # length

The Received number length setting allows you to change the number of digits received on auto-answer trunks. These digits are used to identify target lines, Auto DNs, and DISA DNs. The default for a non-expanded system is 2. The default for an expanded system is 3. Press **CHANGE** to select the setting: 2, 3, 4, 5, 6, or 7. Then, press to enter the new Received number length.

Tips

The target line number (for example, line 181) and the Received number for the target line (for example, Rec'd #: 1234 for line 181) are two different numbers.

The Received number length may be the same as the system DN length, or may, because of network or CO constraints, be set to some other value.

Target lines are supported only on expanded Norstar systems or unexpanded systems that have T1 lines.

Changing the Received number length causes all programmed received digits to be cleared.

Set copy

Set copy allows you to copy programmed data from one telephone to another. You have two choices when deciding which data to copy. You can copy:

- system data only
- system data and personal programming data

System data is programmed in Configuration and Administration. Personal programming data is programmed by people at their own telephones, in order to customize their telephones to their own needs.

Tips

Set copy operates only from the Norstar M7310 or M7324 telephones.

Do not confuse Set copy with the Copy display button. COPY is more selective than Set copy. It allows you to copy specific groups of data from one telephone to another telephone or from one external line to another external line. You can copy more selective groups of System data listed in the table below by pressing COPY when it appears.

If you are copying both system data and personal programming data, the source and destination telephones must each be the same Norstar model. If you are copying System data only, the telephones can be different Norstar models.

Copying data to a telephone overrides any of that telephone's previous programming.

Know which data can and cannot be copied. These are shown in the following two charts.

System data

System data which CANNOT be copied	System data which CAN be copied	
Alarm telephone designation	Answer button assignments	Line pool access
Auto Call Info telephone designation for a line	Automatic Handsfree	Line / Telephone Filter
CAP assignment	Autolog/Show Vmsg	Number of intercom buttons
Direct-dial telephone designation	Auxiliary ringer	Paging
Directory Number (DN) extra-dial telephone designation	Call Forward No Answer	Page Zone
Log space	Call Forward No Answer Delay	Pickup Group
Service Modes Control telephone designation for a line or set	Call Forward On Busy	Prime line designation
Service Modes Ringing telephone designation for a line	Direct-dial Group	Priority Call permission
Prime telephone designation for a line	First Display	Redirect Ring
Private line appearances	Full Handsfree	Ringing line preference
Telephone Name	Handsfree Answerback	Telephone Administration Lock
	Hotline	Telephone Filter
	Line assignment	

Personal programming data

Personal programming data which CANNOT be copied	Personal programming data which CAN be copied
Autobumping	Language Choice
Call log options	Line button positions
Contrast Adjustment	Personal Speed Dial entries
Log password	Telephone memory button assignments (Internal Autodial, External Autodial, and feature access)
Ring type	
Ring volume	
CAP module memory button assignments	
Dialing modes (Automatic Dial, Pre-Dial, Standard Dial)	

Copying set programming

1. Access Configuration programming. The display reads **A. Configuration.**
2. Press until the display reads **C. Set copy.**
3. Press . The display reads **COPY:SYSTEM data.**
4. Press **CHANGE** to toggle the setting.
5. Press .
6. Enter the internal number of the telephone from which you want to copy data.
7. Enter the internal number of the telephone to which you wish to copy data.
8. To copy the same data to another telephone, repeat step 7. Press to return to **C. Set copy.** Press to end the session.

Applying button cap labels

Applying the button cap labels

Before you apply button labels, activate the Button Inquiry feature (Feature *) to verify the button functions, and to avoid activating features as you put the labels onto the buttons.

Keep the extra labels and button caps with each Norstar telephone or leave them with the system coordinator.

Types of button caps

- **Unlabeled, clear button caps**
with appropriate green or grey paper for typing in line numbers, telephone numbers, and features
- **Pre-printed, colored button caps**
in green or grey

Some examples of pre-printed button caps

Green caps	Grey caps
<input type="text" value="Line 1"/>	<input type="text" value="Last No."/>
<input type="text" value="Handsfree Mode"/>	<input type="text" value="Speed Dial"/>

Tips

To make identification of line types easier, use preprinted green button caps for lines that support incoming and outgoing calls. Use clear button caps for target lines that are incoming only.

Identifying the telephones

1. Write the individual telephone numbers on the labels and attach them to the appropriate Norstar telephones.
2. Write the telephone number and the internal number on the appropriate *Norstar Receiver Card* for each type and color of telephone that is to be installed.
3. Cover the *Norstar Receiver Card* underneath the receiver of each telephone with the plastic lens.

Norstar default button assignments

During Startup, the installer chooses one of five default templates: Square, Centrex, Hybrid, PBX and DID. Default features are assigned automatically to the programmable buttons on Norstar telephones, and vary with the template and the telephone. The default features are listed in the tables in this chapter.

Tips

Norstar telephones are shipped from the factory with the button caps in place for the Square template.

Rules of default button assignment

Line and Intercom buttons are assigned by default templates and can be changed in Configuration programming. Handsfree/Mute and answer buttons are not assigned by default. If these features are defined, however, they are automatically assigned to specific buttons, as described on this and the following page. None of these buttons can be assigned to M7100 telephones.

The Handsfree/Mute feature appears on the bottom right-hand button (the bottom button on the M7208 telephone), moving the Intercom button(s) up one position.

Each telephone can have up to eight Intercom buttons. They appear above the Handsfree/Mute button at the bottom right-hand position on your telephone (the bottom button on the M7208 telephone).

Each telephone can have up to four answer buttons. They appear above Intercom buttons in the right column and continue up from the bottom in the left column, replacing the features on those buttons. (On the M7208 telephone, answer buttons appear above Intercom buttons and below external line buttons in a single column.)

External line buttons appear in ascending line order, starting at the top button in the left column (the top button on the M7208 telephone). If more than five external lines are assigned to an M7310 telephone, or more than 12 to an M7324 telephone, assignment continues down the buttons on the right column, erasing the features on those buttons. Line buttons have priority over feature access buttons but not Handsfree/Mute, Intercom, or answer buttons.

M7100 telephone button defaults

For Square, Centrex, Hybrid, PBX, and DID templates, the one programmable button on the M7100 telephone is .

M7208 telephone button defaults

The default button assignments for the M7208 telephone depend on the template applied.

Square	Centrex	Hybrid	PBX	DID
<input type="text" value="Line 1"/>	<input type="text" value="Line<xx>"/>	<input type="text" value="Line 1"/>	<input type="text" value="Pick-Up"/>	<input type="text" value="Line<xx>"/>
<input type="text" value="Line 2"/>	<input type="text" value="Transfer"/>	<input type="text" value="Line pool"/>	<input type="text" value="Transfer"/>	<input type="text" value="Transfer"/>
<input type="text" value="Last No."/>	<input type="text" value="Last No."/>	<input type="text" value="Last No."/>	<input type="text" value="Last No."/>	<input type="text" value="Last No."/>
<input type="text" value="Page"/>	<input type="text" value="Link"/>	<input type="text" value="Page"/>	<input type="text" value="Page"/>	<input type="text" value="Page"/>
<input type="text" value="Conf/Trans"/>	<input type="text" value="Conf/Trans"/>	<input type="text" value="Conf/Trans"/>	<input type="text" value="Conf/Trans"/>	<input type="text" value="Conf/Trans"/>
<input type="text" value="Speed Dial"/>	<input type="text" value="Speed Dial"/>	<input type="text" value="Speed Dial"/>	<input type="text" value="Speed Dial"/>	<input type="text" value="Speed Dial"/>
<input type="text" value="Intercom"/>	<input type="text" value="Intercom"/>	<input type="text" value="Intercom"/>	<input type="text" value="Intercom"/>	<input type="text" value="Intercom"/>
<input type="text" value="Intercom"/>	<input type="text" value="Intercom"/>	<input type="text" value="Intercom"/>	<input type="text" value="Intercom"/>	<input type="text" value="Intercom"/>

Tips

The default Page button activates the External Page option ().

M7310 telephone button defaults

The default button assignments for the M7310 telephone depend on the template applied. The exception is the default numbering for the dual-memory buttons.

Dual-memory buttons

<input type="text" value="Set 233"/>	<input type="text" value="Set 237"/>	<input type="text" value="Set 241"/>
<input type="text" value="Set 221"/>	<input type="text" value="Set 225"/>	<input type="text" value="Set 229"/>
<input type="text" value="Set 234"/>	<input type="text" value="Set 238"/>	<input type="text" value="Set 242"/>
<input type="text" value="Set 222"/>	<input type="text" value="Set 226"/>	<input type="text" value="Set 230"/>
<input type="text" value="Set 235"/>	<input type="text" value="Set 239"/>	<input type="text" value="Set 243"/>
<input type="text" value="Set 223"/>	<input type="text" value="Set 227"/>	<input type="text" value="Set 231"/>
<input type="text" value="Set 236"/>	<input type="text" value="Set 240"/>	<input type="text" value="Set 244"/>
<input type="text" value="Set 224"/>	<input type="text" value="Set 228"/>	<input type="text" value="Set 232"/>

This example shows defaults for a system with three-digit internal numbers.

These defaults do not actually exist on any telephone, as no telephone has an autodial button for itself. The position that would be taken by the autodial button for itself, is blank.

Template button assignments

Square		Centrex		Hybrid	
Line 1	Conf/Trans	Line<xx>	Conf/Trans	Line 1	Conf/Trans
Line 2	Last No.	Transfer	Last No.	Line pool	Last No.
Call Fwd	Voice Call	Call Fwd	Voice Call	Call Fwd	Voice Call
Pick-Up	Intercom	Pick-Up	Intercom	Pick-Up	Intercom
Page	Intercom	Link	Intercom	Page	Intercom

PBX		DID	
DND	Conf/Trans	Line<xx>	Conf/Trans
Transfer	Last No.	Transfer	Last No.
Call Fwd	Voice Call	Call Fwd	Voice Call
Pick-Up	Intercom	Pick-Up	Intercom
Page	Intercom	Page	Intercom

M7324 telephone button defaults

The default button assignments for the M7324 telephone depend on the template applied.

Square		Centrex		Hybrid	
Line 1	Call Fwd	Line<xx>	Call Fwd	Line 1	Call Fwd
Line 2	Speed Dial	blank	Speed Dial	Line pool	Speed Dial
blank	Last No.	blank	Last No.	blank	Last No.
blank	Saved No.	blank	Link	blank	Saved No.
blank	Conf/Trans	blank	Conf/Trans	blank	Conf/Trans
blank	Transfer	blank	Transfer	blank	Transfer
blank	DND	blank	DND	blank	DND
blank	Pick-Up	blank	Pick-Up	blank	Pick-Up
blank	Voice Call	blank	Voice Call	blank	Voice Call
blank	Page	blank	Page	blank	Page
blank	Intercom	blank	Intercom	blank	Intercom
blank	Intercom	blank	Intercom	blank	Intercom

PBX		DID	
blank	Call Fwd	Line<xx>	Call Fwd
blank	Speed Dial	Transfer	Speed Dial
blank	Last No.	blank	Last No.
blank	Saved No.	blank	Saved No.
blank	Conf/Trans	blank	Conf/Trans
blank	Transfer	blank	Transfer
blank	DND	blank	DND
blank	Pick-Up	blank	Pick-Up
blank	Voice Call	blank	Voice Call
blank	Page	blank	Page
blank	Intercom	blank	Intercom
blank	Intercom	blank	Intercom

Testing

After your system has been installed and programmed, test it to verify that the equipment is functioning properly.

	<p>Notify service provider of T1 signaling disruption</p> <p>Notify your T1 service provider before disconnecting your T1 lines, removing power to your system, or performing any other action that disrupts your T1 signaling. Failure to notify your T1 service provider may result in a loss of T1 service.</p>
---	---

Verifying wiring connections

Verify all wiring and connections to make sure they are correct and secure.

Verifying that all modules are enabled

Use **3. Module Status** in Maintenance to verify that all modules are enabled.

Verifying that all ports are enabled

Use **2. Port/DN Status** in Maintenance to verify that all devices and lines are enabled and idle.

Testing the emergency telephones

1. Turn the system power off.
2. Pick up the receiver of each emergency telephone and verify that you hear dial tone.
3. Turn the system power back on.

Tips

The emergency telephone connections on the Trunk Module will not work if there is an E&M/DISA or DID Trunk Cartridge in the first slot of the Trunk Module.

The emergency telephone connections on the KSU will not work if DTIs are used.

Testing the Norstar telephone operations

1. Place a call to each Norstar telephone.
2. Verify the quality and clarity of all connections.
3. Check the visual indicators.
4. Program and use a memory button.

Testing the external lines

1. Place or receive a call on each external line to verify operation.
2. Verify the quality and clarity of each connection.

Testing the T1 lines

1. Run a line loopback or a payload loopback test in coordination with the T1 service provider to verify the T1 link. See Loopback Tests in the Maintenance chapter for information.

Testing the optional equipment

1. Follow the procedures in the user cards or installation documentation for the following equipment:
 - Analog Terminal Adapter (ATA)
 - auxiliary ringer (customer-supplied)
 - Busy Lamp Field (BLF)
 - central answering position (CAP) modules
 - headset (customer-supplied)
 - music source (customer-supplied)
 - paging (customer-supplied)
 - station auxiliary power supply (SAPS)

Testing Norstar system programming features

1. Try using the following programmed system features:
 - Routing
 - System Speed Dial
 - Dialing filters
 - Class of Service
 - Service Modes

Testing Automatic Telephone Relocation

1. Check that Set Relocation is enabled (Y) in **5. Miscellaneous** in Configuration programming.
2. Move a telephone to another location and verify that it has retained all its programming.

Troubleshooting

These troubleshooting procedures allow you to solve many problems in the Norstar system. Follow these procedures before replacing any components.

	<p>Only qualified persons should service system</p> <p>Only qualified personnel should replace components and service hardware.</p>
---	--

Where more than one procedure is given, the procedures represent different options from which you should select just one.

Getting ready

Before you begin troubleshooting, gather all the information that is relevant to your network configuration:

- the *Programming Record*
- records from people who use the network
- information about other hardware and non-Norstar features within the public or private network

	<p>Notify service provider of T1 signaling disruption</p> <p>Notify your T1 service provider before disconnecting your T1 lines, removing power to your system, or performing any other action that disrupts your T1 signaling. Failure to notify your T1 service provider may result in a loss of T1 service.</p>
---	---

Tips

Remember that you can check many of the system parameters without having to go into a Configuration or Administration programming session.

- Use Line Profile (* * L I N E) from an M7310 or M7324 telephone, to check programming for any line.

- Use Set Profile (* * S E T) from an M7310 or M7324 telephone, to check programming for any telephone.
- Use Button Inquiry (* 0) to check the buttons on a particular telephone.

Types of problems

The problems you encounter will likely fall into one of the following categories:

Misunderstanding of a feature

A problem may be reported because a Norstar user is unfamiliar with the operation of a given feature. You may be able to solve the problem simply by demonstrating how to use the feature correctly.

Programming errors

You may encounter problems caused by errors in programming. A feature may have been programmed incorrectly or may not have been programmed at all.

Wiring connections

Wiring problems are caused by loose, unconnected, or incorrect wiring. Use the procedures in the section on Checking the hardware as a guide.

Equipment defects

You may encounter problems caused by Norstar equipment defects. See the appropriate section for problems related to the system hardware.

General troubleshooting procedure

1. Diagnose the trouble by determining:
 - the types of problems users have experienced
 - the frequency of the problems
 - how many telephones are affected

2. Check how a feature is being used. A problem may have been reported because of a misunderstanding about how a feature works. Confirm that the person who reported a problem understands the intended use and operation of any feature in question.
3. Check for programming errors. Check that the programming recorded in the *Programming Record* is correct for the intended operation of the system, and verify that this Configuration and Administration programming has been correctly entered.
4. Check the wiring and hardware connections.
5. If the problem persists, run a Maintenance session as described in the Maintenance chapter.
6. If hardware is defective, replace it. If the trouble requires expert advice, follow your company's procedure for obtaining assistance.

Problems with telephones

Norstar telephone display unreadable

If the trouble is with an M7310 or an M7324 telephone:

1. Press * .
2. Press UP or DOWN to adjust the display to the desired level.
3. Press OK.

If the trouble is with an M7100 or M7208 telephone:

1. Press * .
2. Press a number on the dial pad to adjust the display to the desired level.
3. Press .

If the display is still unreadable:

1. Disable the problem telephone.
2. Replace the problem telephone with a known working one.
3. Enable the working telephone.

Norstar telephone dead

1. If more than one telephone is affected, refer to the Station Module down section.
2. Check for dial tone.
3. Check the display.
4. If the problem persists, replace the telephone with a known working Norstar telephone of the same type (so that the programming is retained).
5. Check the internal wiring at both the modular jack and the distribution cross-connect. A TCM port should have between 15 and 26 V dc across the Tip and Ring when the telephone is disconnected.
6. Check the line cord.

Running a Maintenance session to test a dead telephone

1. Run a Maintenance session to ensure that the telephone is not disabled. (See Port/DN Status in the Maintenance chapter.)
2. Disable the port that the telephone is connected to using the heading **2.Port/DN Status**.
3. Enable the port that the telephone is connected to using the heading **2.Port/DN Status**.

Replacing a telephone

In a powered-up system, an existing Norstar telephone can be replaced by a new Norstar telephone. A new Norstar telephone is one that was not previously in service within the system.

Replacing Norstar telephones of the same type

If an existing Norstar telephone is unplugged, and a new Norstar telephone of the same type is then plugged into the same jack (for example, replacing an M7208 telephone with another M7208 telephone), the new telephone acquires the programming and the internal number of the old telephone. This is normally done to replace a defective telephone.

Replacing Norstar telephones of different types

If an existing Norstar telephone is unplugged, and a new Norstar telephone of a different type is plugged into the same jack (for example, replacing an M7208 telephone with an M7310 telephone), the new telephone keeps the old internal number. The new telephone receives a default profile for a telephone of its type. (Refer to Applying button cap labels in the Programming chapter).

If the telephone being replaced has more lines than the new telephone, automatic outgoing line selection may not work with the Handsfree/Mute feature. A line must be selected manually.

Status of a telephone that was replaced

The old Norstar telephone that was unplugged and replaced by a new Norstar telephone loses its programming and internal number. The old telephone's internal number has been given to the new telephone and the programming has either been removed or given to the new telephone when it was plugged into the old jack. The replaced telephone (if still functional) is now treated by the system as a telephone not previously in service.

Emergency telephone dead

1. Verify that there is no power at the KSU and Trunk Modules.
2. Verify that there is no dial tone at the emergency telephone.
3. Check that the external line and emergency telephone connections have been made correctly.
4. Ensure that the emergency telephone is not faulty by connecting it directly to the external line and listening for dial tone.
5. Verify that the KSU has a Loop Start Trunk Cartridge installed. Verify that the Trunk Module has a Loop Start Trunk Cartridge installed in the left-most slot.
6. Verify that there is dial tone on lines 002 (ET1 on TC1) and 026 (ET2 on TC2) of the KSU and on the first line of each Trunk Module.
7. Replace the KSU if the emergency telephone is connected to the KSU or replace the Trunk Module if the emergency telephone is connected to the Trunk Module.

Problems with lines

The troubleshooting problems listed here focus on trouble with making calls or using lines.

Calls cannot be made (but can be received)

1. Press * 0.
2. Press a line button.
3. If an incorrect line number or name appears (or if neither appears) on the Norstar telephone display, check the Configuration settings.
OR
If the correct line number or name appears on the Norstar telephone display, make sure the external lines are properly cross-connected.
4. Check external lines by attaching a test telephone directly on the distribution block.
5. Ensure that the 25-pair cable is properly connected to the modules or the KSU.
6. Run a Maintenance session and verify that the module that the Trunk Cartridge is installed in is not disabled or unequipped using the heading **3.Module Status**.
7. Run a Maintenance session and disable the appropriate ports using the heading **2.Port/DN Status**. For charts showing external line port number defaults, refer to Installing the hardware.
8. Enable the appropriate ports using the heading **2.Port/DN Status**.

9. If you still cannot make external calls, power down, then power up the system. This should be done after business hours to avoid losing calls.

	<p>Notify service provider of T1 signaling disruption</p> <p>Notify your T1 service provider before disconnecting your T1 lines, removing power to your system, or performing any other action that disrupts your T1 signaling. Failure to notify your T1 service provider may result in a loss of T1 service.</p>
---	---

10. To check the line, contact the telephone company.

Dial tone absent on external lines

1. Use Button Inquiry (: * : 0) to display the number of the external line you are testing.
2. Check for dial tone using a test telephone at the connections for the external line on the distribution block.
3. Make sure that a Trunk Cartridge for the line is properly installed in the KSU or Trunk Module.
4. Make sure that the Trunk Module fiber cable is properly connected to the Expansion Cartridge on the KSU.
5. Refer to the sections Trunk Cartridges and Trunk Module down, in this chapter.
6. Run a Maintenance session to ensure that the line is not disabled. (See Port/DN Status in the Maintenance chapter.)

Hung lines at a telephone

Line indicators that have been solid for a long time are the only visible indication that lines are hung.

Possible problem

A line that has been redirected using Line Redirection may, under some circumstances, remain busy after a call is over. If this happens, the outgoing line for the redirection also remains busy. You can clear this kind of hung line only at the telephone that was used to redirect the line.

Solution

1. Enter the Button Inquiry feature code (* 0) at the telephone that was used to redirect the line.
2. Press the button of the redirected line.
3. Press SHOW or .
4. Press DROP or .

Both the redirected line and the outgoing line for the redirection should now be cleared.

Possible problem

The supervision and/or Discon timer programming for the line do not match the settings for the line at the central office.

Solution

1. Verify that your programming for the line matches the central office settings.

Possible problem

Other.

Solution

For lines that are hung for any other reason, you will have to run a Maintenance session.

1. Run a Maintenance session and go to the heading
3. **Module Status**.
2. Disable and enable the affected Trunk Cartridge.

Follow the procedures in the Troubleshooting overview and the Installation check sections before proceeding.

Auto-answer line rings at a Norstar telephone**Possible problem**

You configured a loop start trunk as auto-answer but the installed hardware does not support disconnect supervision. (In this case, the symptom would be accompanied by the Alarm 62 code symptom.)

Solution

1. Reconfigure the trunk as manual-answer.

OR

Replace the Trunk Cartridge with one that provides disconnect supervision.

Possible problem

The line is configured as auto-answer and unsupervised.

Solution

1. Reconfigure the line as manual-answer.

OR

Reconfigure the line as supervised.

Possible problem

The line is not equipped for disconnect supervision at the central office.

Solution

1. Reconfigure the trunk as manual-answer.

Possible problem

The Discon timer setting for the Trunk Cartridge in

1. **Trk/Line Data** does not match the setting for the line at the central office.

Solution

1. Reconfigure the Discon timer to match the setting at the central office.

Prime telephone gets misdialed calls

Possible problem

The digits sent by a switch at a central office or in the private network did not match any Received number, the Auto DN, or the DISA DN. The call has been routed to the prime telephone for the incoming trunk.

Solution

1. Verify that the switch is sending the correct number of digits for the Received number length defined in your system.
2. Verify all the digit strings that the switch should be sending.

3. Check that you have defined the corresponding Received number for every target line in your system.
4. Make sure that the published telephone numbers for your network are correct.

Selected line reads *Not in service* **OR** *Not available*

Possible problem

You have configured a line number associated with an E&M Trunk Cartridge DTMF receiver to appear at the telephone.

Solution

1. Reconfigure the line so that it does not appear at any telephone and configure another line to replace it at the telephone.

OR

Reconfigure the line as a different type and install trunk hardware to support the new type of line.

Possible problem

The Norstar system has taken an E&M line out of service because the far end did not respond to a disconnect signal from the Norstar system. The symptom would be accompanied by event code 263 in the System Test Log.

Solution

1. Check with the operators of the system at the far end and find out if their system is operating.
2. Check that your system hardware is receiving signals properly.
3. Check the trunk between your system and the far end system for a break.
4. Check that your trunk is properly configured.
5. Run a Maintenance session and go to the heading **3. Module Status.**
6. Disable and enable the affected Trunk Cartridge.

Possible problem

The Norstar system has detected no response on an E&M line from the system at the far end. The symptom will be accompanied by Event code 265 in the System Test Log.

Solution

1. Check with the operators of the system at the far end and get them to troubleshoot their system.

Possible problem

The line is connected to a DTI which is currently not in service.

Solution

1. Check if the green LED on the DTI is flashing to indicate that service is suspended.
2. Check if any yellow LEDs are on to indicate an alarm or error condition.
3. Check if the red test LED is on to indicate that a continuity loopback test is running.
4. Check that the cable connecting the DTI to the termination point from the central office or network is properly connected.
5. Check that the DTI is properly inserted in the KSU.
6. Run a Maintenance session to verify the status of the DTI.

Possible problem

The line has been disabled for maintenance purposes.

Solution

1. Enable the line.

OR

If the line will be out of service for some time, configure another line to replace it on the telephone.

Selected line pool shows No free lines

Possible problem

If this happens often, there are not enough lines in the line pool to serve the number of line pool users.

Solution

1. If the line pool contains loop start trunks, enter Configuration and move under-used loop start trunks from other line pools into the deficient line pool.

OR

If the line pool contains E&M trunks, order more trunks from the telephone company or private network vendor. Install additional Trunk Cartridges of the appropriate type. In Configuration programming, add the new trunks to the deficient line pool.

Problems with optional equipment

Analog Terminal Adapter

1. Check the connections to the jack.
2. Check the connections to the ATA.
3. Disconnect the ATA and replace it with a working Norstar telephone. If the telephone still works properly, the KSU and/or the SM are operating properly.
4. Verify that the programming has been done as described in the *Programming Record* and the *Norstar Analog Terminal Adapter Installation Card*.
5. If the trouble seems to be in the KSU or SM, double-check all wiring and programming options. If this does not help, refer to the sections on KSU down or Station Module down.

OR

If the trouble seems to be with the ATA, disable the ATA and replace it with a known working one.

Running a Maintenance session to test an ATA

1. Run a Maintenance session to ensure that the ATA is not disabled. (See Port/DN Status in the Maintenance chapter.)
2. Disable the port connected to the ATA using the heading **2.Port/DN Status**.
3. Enable the port connected to the ATA using the heading **2.Port/DN Status**.

Auxiliary ringer

1. If the auxiliary ringer is used for Service Modes (Night, Evening, or Lunch service), ensure that Service Modes is activated from the control telephone.
2. Check the wiring between the auxiliary ringer generator and the ringing device. Refer to the auxiliary ringer wiring chart.
3. Check the wiring between the auxiliary ringer generator and the distribution block:

Auxiliary ringer wiring

Feature	Pin
Auxiliary ring (Make)	44 (Yellow-Brown)
Auxiliary ring (Common)	19 (Brown-Yellow)

4. Ensure that the auxiliary ringer contacts are operating properly by checking with an ohmmeter across the auxiliary ringer pin contacts listed above.
5. Check that the auxiliary ringer pin contacts are programmed to operate in conjunction with any or all of the features in the auxiliary ringer programming chart.

Auxiliary ringer programming

Feature	Programmed in	
Auxiliary ringer: Lines	Configuration:	Line Data
Auxiliary ringer: Sets	Administration:	Telephone abilities
Service Modes	Administration:	Service Modes

The current capacity of the Norstar relay contacts is 50 mA dc. They are designed to operate with the auxiliary ringer generator, or equivalent.

External paging

1. Use the Button Inquiry feature (*) to verify the feature of a programmable memory button.
2. Check the wiring between the 50-pin connector and the paging amplifier or between the connections shown in the external paging wiring chart.

External paging wiring

Feature	Pin
Page out (Tip)	40 (Black-Slate)
Page out (Ring)	15 (Slate-Black)
Page (Make)	41 (Yellow-Blue)
Page (Common)	16 (Blue-Yellow)

3. Test external paging to ensure that it is working. The nominal output signal from the Norstar KSU is 775 mV across 600 Ω .

Music on Hold/Background Music trouble

Although Music on Hold and Background Music are separate features, they share the same wiring and customer-supplied music source.

1. Ensure that the proper feature access code () is turned on. Adjust the volume using the volume control bar.
2. Use the Button Inquiry feature () to verify the feature on a programmable memory button.
3. If there is trouble with Music on Hold, check **4. Call Handling** in Configuration.
OR
If there is trouble with Background Music, check **5. Miscellaneous** in Configuration.
4. Check the wiring between the music source and the 50-pin connector. See the wiring charts in the Installing the hardware.
5. Ensure that the music source is turned on, is operational, and the volume control is set properly.
6. Any music source with a low-output impedance (for example, less than 3,300 ohms) can be connected. The output level must be less than one volt.

Problems with modules

Check first for user problems, then wiring and programming errors before replacing Norstar equipment.



Notify service provider of T1 signaling disruption

Notify your T1 service provider before disconnecting your T1 lines, removing power to your system, or performing any other action that disrupts your T1 signaling. Failure to notify your T1 service provider may result in a loss of T1 service.

Trunk Cartridge trouble

1. Check that the cartridge is properly inserted in the KSU or Trunk Module.
2. Run a Maintenance session to ensure that the cartridge is not disabled.

If the problem persists, follow as many of the next steps as required to solve the problem.

If the Trunk Cartridge is installed in the KSU:

1. If ac power is present and the LED indicator on the KSU is off, replace the KSU.

If the Trunk Cartridge is installed in a Trunk Module:

1. If ac power is present and the LED indicator on the Trunk Module is off, replace the Trunk Module.
2. Replace the fiber cable.
3. Replace the Trunk Cartridge.
4. Replace the Expansion Cartridge.
5. Replace the KSU.

Refer to the Installation chapter for information on replacing components.

Digital Trunk Interface trouble

1. Run a Maintenance session to verify that the Trunk Cartridge is enabled and that it's lines are provisioned.
2. Check the LEDs on the front of the DTI:

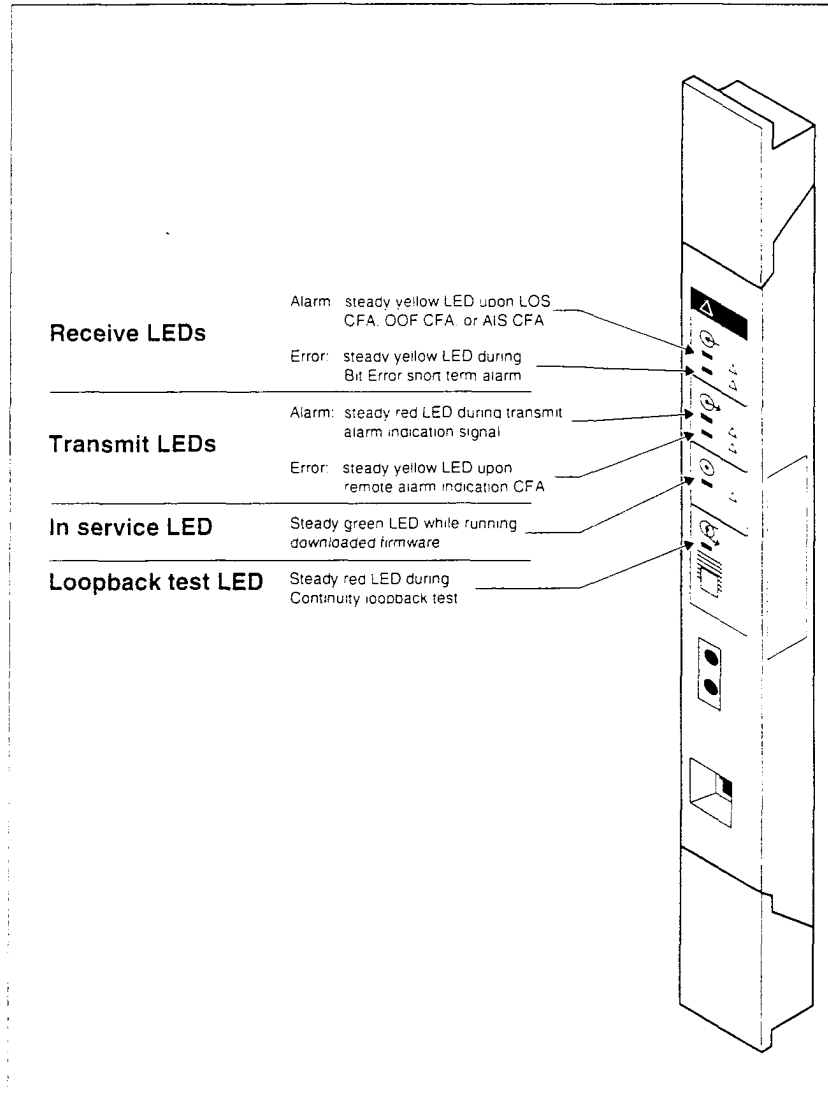

Receive Alarm: yellow LED on indicates a problem with the digital transmission being received. This half-duplex link is unusable.

Receive Error: yellow LED indicates a minor error as a result of degraded digital transmission. Possible causes are an ohmic connection, water ingress, or too long a loop.

Transmit Alarm: red LED on indicates an inability to transmit. Alarm indication signal (AIS) is being transmitted to the terminating switch. This half-duplex link is unusable.

Transmit Error: yellow LED on indicates a remote alarm indication (RAI) carrier failure alarm (CFA) is being sent to the terminating switch. If the Transmit Alarm is not on, this indicates a far-end or cable problem.

In service: flashing green indicates that the T1 trunks are out of service because of a running loopback test, or because the DTI is being initialized.

Loopback test: red LED on while a continuity loopback test is running.

All LEDs flashing continuously: the DTI is being initialized.

3. Run a Maintenance session and any loopback tests as appropriate.
4. Check the pinout of the cable that connects the DTI to the termination point from the T1 service provider or the external channel service unit, and check that the cable is properly connected.
5. Check with your T1 service provider to see if through-fed repeaters are used on the T1 span. The DTI does not provide the DC connection required for through-fed repeaters. If through-fed repeaters are used on the T1 span, disable the internal CSU and connect the DTI to an external CSU.
6. If the problem persists, replace the DTI.

**Notify service provider of T1 signaling disruption**

Notify your T1 service provider before disconnecting your T1 lines, removing power to your system, or performing any other action that disrupts your T1 signaling. Failure to notify your T1 service provider may result in a loss of T1 service.

Monitoring the T1 signal

If you are finding minimal faults with the T1 signal, you can monitor the signal to try and isolate the problem. The monitor jack on the DTI faceplate provides non-intrusive, bridged in-service monitoring of the T1 signal. Connect a protocol analyzer or other test equipment into the monitor jack to monitor the signal received from the network, and the signal transmitted by Norstar.

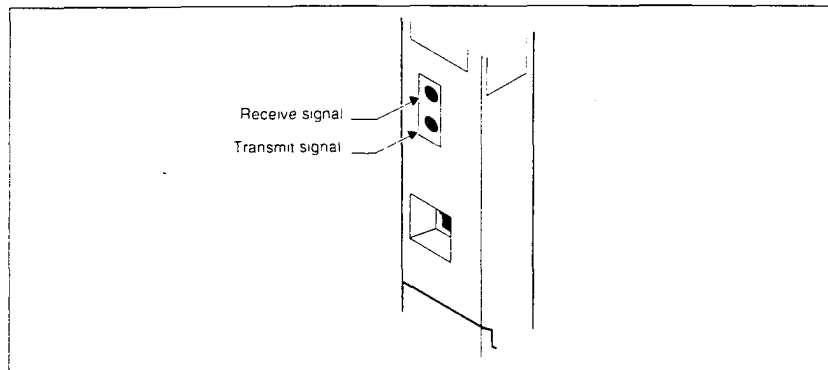

KSU down

1. If ac power is present and the LED indicator on the KSU is off, replace the KSU power supply.

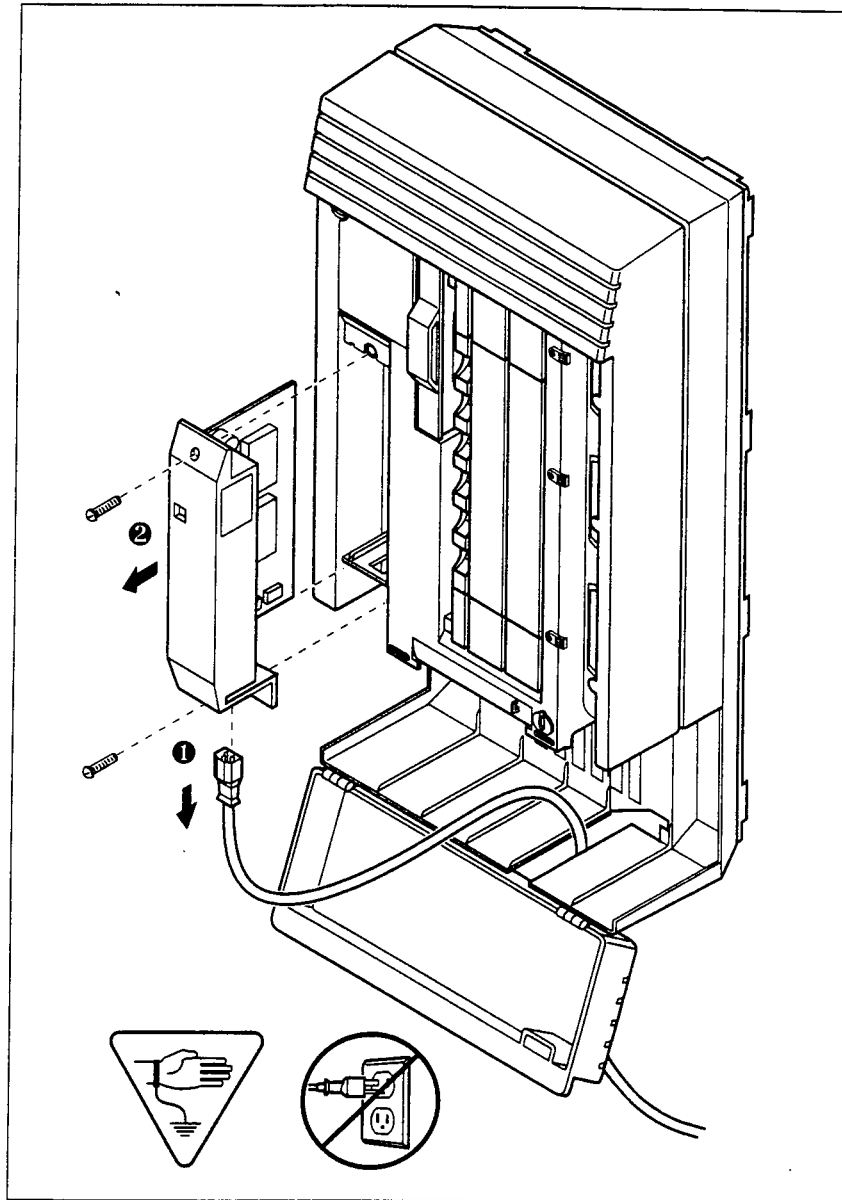

Trunk Module down

1. Run a Maintenance session to ensure that the Trunk Module is not disabled. (See the Maintenance chapter.)
2. Disable the module using the Maintenance heading
3.Module Status.
3. Enable the module using the Maintenance heading
3.Module Status.
4. Check the external line by terminating a single-line telephone directly on the distribution block, or equivalent, which connects to the Trunk Module.

If the problem persists, follow as many of the next steps as required to solve the problem:

1. If ac power is present and the LED indicator on the Trunk Module is off, replace the Trunk Module.
2. Replace the fiber cable.
3. Replace the Trunk Cartridge.
4. Replace the Expansion Cartridge.
5. Replace the KSU.

Refer to the Installation chapter for information on replacing components.

Station Module down

1. Run a Maintenance session to ensure that the module is not disabled. (See the Maintenance chapter.)
2. Disable the Station Module using the heading
3.Module Status.
3. Enable the Station Module using the heading
3.Module Status.
4. If the Station Module is still down, power down, then power up the KSU.

If the problem persists, follow as many of the next steps as required to solve the problem:

1. If ac power is present and the LED indicator on the Station Module is off, replace the Station Module.
2. Replace the Fiber cable.
3. Replace the Expansion Cartridge.
4. Replace the KSU.

Refer to the Installation chapter for information on replacing components.

Problems for network or remote users

Remote feature code gets no response

Possible problem

A Norstar user has called into another Norstar system and is trying to activate a remote feature but gets no response after dialing the feature code.

Solution

1. Make sure that the remote caller is dialing the feature code correctly. Use the asterisk (*) character, followed by the feature code, to activate a remote feature. (Do not use for accessing features on a remote Norstar system.)
2. Make sure that the remote user is dialing tones, not pulses once the call is answered.

Dialed number gets ringback and the wrong person

Possible problem

The digits sent by a switch at a central office or in the private network did not match any Received number, the Auto DN, or the DISA DN. The call has been routed to the prime telephone for the incoming trunk.

Solution

1. Verify that the switch is sending the correct number of digits for the Received number length defined in your system.
2. Verify all the digit strings that the switch should be sending.
3. Check that you have defined the corresponding Received number for every target line in your system.
4. Make sure that the published telephone numbers for your network are correct.

Dialed number gets stuttered dial tone instead of ringback

Possible problem

The remote caller has tried to reach a Norstar target line, but has reached a trunk with DISA instead. Alternatively, the Norstar system has mapped incoming digits onto the DISA DN.

Solution

1. Verify all the digit strings that the switch should be sending.
2. Check that you have defined a corresponding Received number for every target line in your system.
3. Check that you have defined the correct DISA DN for your system.
4. Make sure that the published telephone numbers for your network are correct.

Dialed number gets dial tone instead of ringback

Possible problem

The remote caller has tried to reach a Norstar target line, but has reached the Norstar system instead. Norstar has mapped the incoming digits onto the Auto DN.

Solution

1. Verify all the digit strings that the switch should be sending.
2. Check that you have defined the corresponding Received number for every target line in your system.
3. Check that you have defined the correct Auto DN for your system.
4. Make sure that the published telephone numbers for your network are correct.

Dialed number gets busy tone

Possible problem

The target line that the incoming digits map onto is busy, and there is no prime telephone for the incoming trunk.

Solution

1. For maximum call coverage, make sure that you configure a prime telephone for every incoming trunk.

Dialed number does not get through

Possible problem

The digits sent by a switch at a central office or in the private network did not match any Received number, the Auto DN, or the DISA DN. There is also no prime telephone assigned for the incoming trunk. In this case, the caller may hear overflow tone from the Norstar system or a recorded message from the originating switch.

Solution

1. Configure a prime telephone for every incoming trunk.
2. Verify that the switch is sending the correct number of digits for the Received number length defined in your system.
3. Verify all the digit strings that the switch should be sending.
4. Check that you have defined a Received number for every target line in your system.
5. Make sure that the published telephone numbers for your network are correct.

Possible problem

The Norstar system did not receive some or all of the incoming digits.

Solution

1. Check that the system hardware is receiving signals properly.
2. Verify that the switch is sending the correct number of digits for the Received number length defined in your system.
3. If the switch at the far end is sending pulse signals, make sure they are being sent at the proper rate. (Pulse digits must be 300 ms or more apart for Norstar to receive them.)

Possible problem

If remote callers are having difficulty getting through from the public network, there may be a problem with your DID Trunk Cartridge.

Solution

1. Connect a single-line DTMF telephone to a DID trunk input on the DID Trunk Cartridge.
2. Use the single-line telephone to enter a Received number that has been programmed for a target line in your system. Listen for ringback.
3. If you do not hear ringback, check that the target line is assigned to a telephone and that there is a prime telephone assigned for the DID trunk.
4. If you now hear ringback, but you also hear the noise of your unanswered call ringing, check the cross-connections. If all the cross-connections are correct replace the Trunk Cartridge.

Possible problem

If remote callers are having difficulty getting through from the private network, there may be a problem with your E&M/DISA Trunk Cartridge.

Solution

1. Check the cross-connections for the E&M/DISA Trunk Cartridge.
2. If the E&M trunks are connected to another Norstar system, make sure that connections have been made as indicated in the Technical data chapter.
3. Use the following table to check for correct voltage on the E&M/DISA leads:

Voltages on E&M leads

Leads	Voltage: active	Voltage: inactive
V T-R	125 mV ac on steady dial tone	0 V ac
V T1-R1	125 mV ac on steady dial tone	0 V ac
V E-SG	0 V dc to -5 V dc	-48 V dc
V M-SB	0 V dc to + 2 V dc	-48 V dc

Dialed DISA number gets ringback instead of stuttered dial tone

Possible problem

The remote caller has dialed a DISA number, but has instead reached a target line, or has been routed to the prime telephone for the auto-answer trunk. The Norstar system has mapped the incoming digits from a switch onto a target line, or has been unable to map the digits anywhere.

Solution

1. Verify that the switch is sending the correct number of digits for the Received number length defined in your system.
2. Verify all the digit strings that the switch should be sending.
3. Check that you have defined the correct DISA DN for your system.
4. Make sure that the published telephone numbers for your network are correct.

Dialed DISA number gets dial tone instead of stuttered dial tone

Possible problem

The remote caller has dialed a DISA number, but has reached the Norstar system instead. The Norstar system has mapped the incoming digits from a switch onto the Auto DN.

Solution

1. Verify that the switch is sending the correct number of digits for the Received number length defined in your system.
2. Verify all the digit strings that the switch should be sending.
3. Check that you have defined the correct DISA DN for your system.
4. Make sure that the DISA DN and Auto DN are different enough to prevent misdialing.
5. Make sure that the published telephone numbers for your network are correct.

DISA user gets overflow tone when entering COS password

Possible problem

The remote caller may have entered an invalid password.

Solution

1. Check the Administration programming under COS passwords and verify that the caller has a valid password.

Possible problem

The remote caller may have entered an asterisk (*) as one of the 6 digits.

Solution

1. Instruct remote callers to enter their COS password correctly: enter 6 digits.

Possible problem

The remote caller may have entered a number sign (#) as one of the 6 digits.

Solution

1. Instruct remote callers to enter their COS password correctly: enter 6 digits. The number sign (#) may be entered after the 6th digit, but is not required.

Possible problem

The remote caller may have waited more than 15 seconds between entering digits.

Solution

1. Instruct remote callers to enter their COS password correctly: enter 6 digits, and do not pause too long between digits.

Possible problem

The caller may be dialing from a rotary-dial telephone or from a push-button telephone that uses pulse signaling.

Solution

1. Inform remote callers that they must dial from a push-button telephone that uses DTMF "tone" signaling.

Dialed feature code gets overflow tone

Possible problem

The remote caller does not have access to that feature.

Solution

1. If the call came in on a trunk with DISA, check the Class of Service that is associated with the remote caller's COS password. If it is too restrictive, modify the remote package assigned to the COS password, or assign another COS password that is more suitable.
2. If the call came in on a trunk without DISA, check the remote package that you assigned to the incoming trunk. Make sure that it gives the appropriate access to the remote caller.

Possible problem

The feature code is not valid.

Solution

1. Make sure that remote callers have a correct listing of the features that are programmed for remote access.
2. Ensure that remote callers are dialing the feature code correctly. Press ***** followed by the feature code to activate a remote feature.

Possible problem

The caller may be dialing on a rotary-dial telephone or on a push-button telephone that uses pulse signaling.

Solution

1. Inform remote callers that they must dial from a push-button telephone that uses DTMF "tone" signaling.

Dialed feature code gets busy tone

Possible problem

A resource that the remote feature uses may currently be in use. For example, a remote caller trying to use the paging feature would get a busy tone if the auxiliary speaker were being used at the time.

Solution

1. If repeated attempts to use the remote feature get busy tone, there may be a malfunction in a resource that the feature uses. Check that the remote feature hardware is functioning normally.

Line pool access code gets overflow tone

Possible problem

If the published line pool access code is valid, the remote caller does not have access to that line pool.

Solution

1. If the incoming trunk answers with DISA, give the remote caller a COS password that permits access to that line pool.

OR

Change the remote package for the incoming trunk so that it permits access to that line pool.

OR

Give the remote caller a line pool access code that is permitted within the Class of Service on the incoming trunk.

Possible problem

If the published line pool access code is invalid, the system has attempted, without success, to match the invalid code to a Norstar target line internal number, and there is no prime telephone for the auto-answer trunk.

Solution

1. Make sure that the published line pool access codes are correct.
2. Check that the line pool access codes have been entered correctly under **4. Miscellaneous** in Configuration programming.

Possible problem

The caller may be dialing from the network on a rotary-dial telephone or on a push-button telephone that uses pulse signaling.

Solution

1. Inform remote callers that they must dial from a push-button telephone that uses DTMF "tone" signaling.

Line pool access code gets ringback

Possible problem

The published line pool access code is invalid, and the system has routed the call to the prime telephone for the incoming trunk.

Solution

1. Make sure that the published line pool access codes are correct.
2. Check that the line pool codes have been entered correctly under **4. Miscellaneous** in Configuration programming.

Line pool access code gets busy tone

Possible problem

There are not enough lines in the line pool to serve the number of users.

Solution

1. If the line pool contains loop start trunks, enter Configuration and move under-used loop start trunks from other line pools into the deficient line pool.

OR

If the line pool contains E&M trunks, order more trunks from the telephone company or private network vendor. Install additional E&M Trunk Cartridges. In Configuration programming, add the new trunks to the deficient line pool.

OR

Create a separate line pool for remote users only.

Possible problem

There are DID lines in the line pool.

Solution

1. In Configuration programming, make sure that there are no DID lines in any of the line pools.

Dialed number gets no response

Possible problem

The remote caller, after accessing a line in a line pool, may have started dialing before the far end was ready to receive digits.

Solution

1. Instruct remote callers to wait until they hear feedback before entering any digits.

Possible problem

There may be a malfunction in the line that the remote caller accessed.

Solution

1. If the problem is persistent, check that all lines in the affected line pool are functioning normally.

Possible problem

There may be a malfunction in the system that the caller is trying to reach.

Solution

1. Inform the operators of the system at the far end that the dialed number is not getting through.

Maintenance

Maintenance overview

A Norstar Maintenance session helps you diagnose problems that may occasionally arise within the Norstar system. Maintenance also includes settings to determine how the system will deal with T1 digital lines, and provides a means for provisioning and testing digital lines.

The Maintenance section of programming has ten headings.

1. System Version	displays the version number of the system processor.
2. Port/DN Status	allows you to check and change the status of ports in your system.
3. Module Status	allows you to check and change the status of modules in your system.
4. Sys Test Log	displays a list of test results, event messages, and alarm codes.
5. Sys Admin Log	displays a list of system initializations, Configuration sessions, invalid password attempts and password changes.
6. Network Log	displays a list of T1 events and alarms.
7. Clock Source	allows you to select which DTI obtains the clock frequency from the T1 network.
8. Provisioning	allows you to add or remove individual T1 lines from service.
9. Loopback Tests	allow you to test incoming T1 signals to evaluate transmission quality.
10. CSU Stats	displays T1 performance information supplied by the Channel Service Unit.

You can run a Maintenance session from any working Norstar M7310 or M7324 telephone. Only one person at a time can access a Maintenance session. Photocopy the Maintenance records found at the end of this chapter, and keep a pencil handy to record important information.

Beginning a Maintenance session

1. Release all calls on your telephone.
2. Press * * C O N F I G which is the same as * * 2 6 6 3 4 4 . The display reads **Password: .**
3. Enter the Installer password. The display reads **A. Configuration.** Three triangular indicators ► appear on the vertical display between the rows of buttons.
4. Place the programming overlay over the buttons pointed to by the indicators ►.
5. Press until the display reads **D. Maintenance.**

System Version

System Version allows you to note the version number of the System Processor (SP) software, which resides in the Feature Cartridge.

The SP version number can be used to determine whether you have the latest software release, and to trace a software fault if one occurs. For instance:

- SP version number can indicate a Feature Cartridge incompatibility.
- SP and telephone version numbers can indicate a telephone version incompatibility.
- SP and functional terminal version numbers can indicate a functional terminal incompatibility.

Checking the version of the system

To check the version number, start with the display reading

D. Maintenance:

1. Press . The display reads **1.System Version**.
2. Press . The display shows the version number of the SP.
3. Write the SP version number on the appropriate Maintenance record.
4. Press . The display reads **1.System Version**.

Port/DN Status

Port/DN Status allows you to:

- identify any device or line connected to the system
- check the version number of a device (an Analog Terminal Adapter, for example) for compatibility with the system
- check the state of a device or line (for example, idle or busy)
- disable or enable a device
- determine which port number corresponds to each DN
- determine the port number of a malfunctioning device
- determine if a malfunctioning device is incompatible with the Norstar system
- disable a device before replacing it

Tips

You cannot disable the Norstar telephone from which you are accessing the Maintenance session. If you try to do this, a message appears on the display and you hear an error tone. If you want to disable that particular telephone, conduct the Maintenance session from another Norstar telephone.

	<p style="text-align: center;">Pick a suitable time to disable devices</p> <p>Do not disable devices when many people are using the Norstar system. Wait until after regular office hours.</p>
---	---

Do **not** enable or disable ports at the following times:

- during the first two minutes after Startup programming
- before fiber cables are connected

If you do so, incorrect ports may be enabled or disabled. To recover from this, disable then enable the affected modules using Module Status.

Port/DN Status allows you to check lines and devices on the system. Although the following procedures describe how to check devices, you can use the same procedures to check lines.

Lines can only be disabled in **3. Module Status**.

Identifying a device connected to the system

Start with the display reading **1. System Version**:

1. Press . The display reads **2. Port/DN Status**.
2. Press . The display reads **Show port:**.
3. Enter the port number of the device, or press **DN**, then enter the directory number of the device. The display shows device information, as illustrated in the following sample device identification display. This identifies the device connected to the B1 channel.
4. If there is an add-on device attached to a Norstar telephone such as a central answering position module or a Busy Lamp Field, press to display the add-on device.
5. Press **>B2** to display the device connected to the B2 channel.
6. Press until the display reads **2. Port/DN Status**.

Displays

Sample device identification display

P104 7324 224	This sample display indicates that port
UESRN >B2 STATE	104 has an M7324 telephone whose DN is
	224.

The following table lists some of the device types that may appear on the Norstar device identification display.

Explanation of device type

Display	Explanation
7100	M7100 telephone
7208	M7208 telephone
7310	M7310 telephone
7324	M7324 telephone
1: MODULE1	First CAP module attached to an M7324 telephone
2: MODULE2	Second CAP module attached to an M7324 telephone
ATA	Analog Terminal Adapter
BLF	Busy Lamp Field

Checking the version number of the device

From the Norstar device identification display:

1. Press VERSN (if it is available). The display shows the version number of the device.
2. Write this number on the appropriate Maintenance record.

To return to the Norstar device identification display from the display showing the version number:

1. Press OK to retain the same port number.
OR
 Press to see information about the next port number (or DN if that is how you entered).
OR
 Press to see information about the previous port number (or DN if that is how you entered).

Checking the state of the device

From the Norstar device identification display:

1. Press **STATE**. The display shows one of the states listed in the table on the following page.
If you want, you can disable or enable the device (see the procedures in this chapter).
2. Press **OK** to return to the device identification display.

How the device state is shown on the display

Display	State of device
Busy DISABLE OK	The device is in use.
Disabling... OK	The device is being disabled.
Enabling... OK	The device is being enabled.
Idle DISABLE OK	The device is not in use.
Unequipped DISABLE OK	There is no device connected to that port.
Disabled by user ENABLE OK	The device has been disabled by someone running a Maintenance session.
Disabled by sys. ENABLE OK	The device has been disabled by the system because it is faulty or because a test is running.
Not available DISABLE OK	There is no state available.

Disabling a device

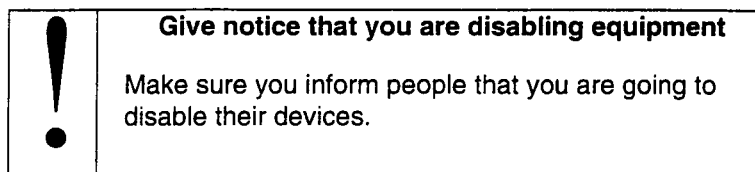

To disable immediately when the display indicates the device is busy:

1. Press DISABLE. The display reads `Disable at once?`.
2. Press YES. The system prompts the device user and disables the device in one minute (or immediately, if the device is idle). Press EXIT to leave this display without disabling the device.

Displays

The following table show examples of the sequence of messages that might appear on a telephone when you disable a device.

Examples of display messages

<p><code>Please hang up Maintenance test</code></p> <p><code>48 seconds until disconnect</code></p> <p><code>Please hang up</code></p>	<p>Occurs on a busy telephone before disabling</p>
<p><code>In Maintenance</code></p>	<p>Occurs after disabling</p>

Enabling the device

When the display shows you that the device is disabled:

1. Press **ENABLE**. The display briefly reads **Enabling...** The device is immediately enabled and the display reads **Idle**.

Tips

The display may briefly read **Enabling...**, then either **Disabled by sys.** or **Disabled by user**. In this case, the system is waiting to enable the module. This may occur after someone has run a Maintenance session and used Module Status. You cannot enable the device until its module has been enabled.

Individual lines cannot be disabled in **2.Port/DN Status**. To disable a Trunk Cartridge, see Module Status.

Returning to the beginning

From the display showing the state of the device:

1. Press **OK**.
2. Press until the display reads **2.Port/DN Status**.

Module Status

Module Status allows you to:

- look at the inventory of Station Modules, Trunk Modules, and modules inside the Key Service Unit
- check the number of Trunk Cartridges in a module
- check the state of the module or its cartridges
- disable or enable the module or its cartridges
- isolate any malfunctioning modules
- disable a module before replacing it
- clear a hung line by disabling and enabling the affected Trunk Cartridge

Module numbering schemes for two-port and six-port Expansion Cartridges

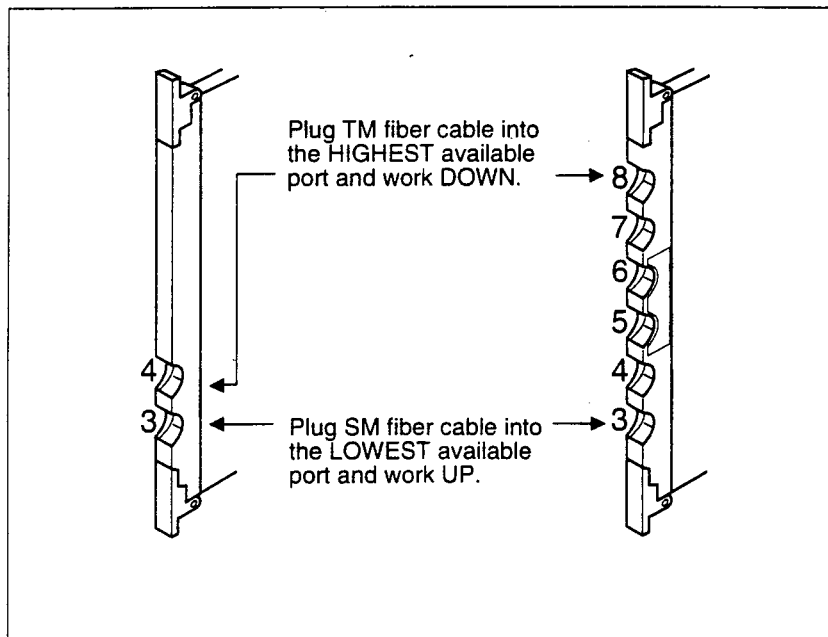

Tips

Modules 1 and 2 are located inside the KSU. Module 1 connects Norstar telephones. Module 2 connects Trunk Cartridges.

Looking at the module inventory

Start with the display showing **2.Port/DN Status**:

1. Press . The display reads **3.Module Status**.
2. Press . The display reads **Show module:**.
3. Enter the module number. Modules 1 and 2 are located inside the KSU. Refer to the figures on the previous page for the module numbering scheme.

If you choose module 1, the display shows how many telephones KSU. If you choose module 2, the display shows the number of Trunk Cartridges connected to the KSU; the KSU is identified as TM2.

If you are checking a Trunk or Station Module, the display shows either how many Trunk Cartridges are connected to the Trunk Module or how many devices are connected to the Station Module.

Tips

Norstar devices may occupy both the B1 and B2 channels. This may increase the number of devices indicated on the module inventory display.

Checking the number of Trunk Cartridges attached to a module

Start from the module inventory display, which shows the number of Trunk Cartridges connected to the module you chose (for example, **3 TCs on TM 4**).

1. Press **TC**. If there is a Trunk Cartridge in a slot, the display shows that four lines are connected (for example, **4 lines on TC 1**).
2. Press or to check for Trunk Cartridges in the other slots.
3. Press **MODULE** to return to the module inventory display.

Checking the state of a cartridge

Start from the display that shows the number of lines connected to the Trunk Cartridge you chose (for example, **4 lines on TC 1**).

1. Press **STATE**. The display shows the state of the cartridge. Some examples of this display are shown on the previous page.
2. Press or to check the Trunk Cartridges connected to the other Trunk Modules.
3. If required, you can disable or enable the cartridge. (See the procedures in the following two sections.)
4. Press **OK** to return to the display showing how many lines are connected to the Trunk Cartridge.

Disabling a module or its cartridges

	<p>Use Page feature prior to disabling</p> <p>Use the Page feature to inform people that you are about to disable a module. Mention that they may experience delays in the performance of their devices.</p>
--	---

From the display showing the state of the module or cartridge:

1. Press **DISABLE**. The display reads **Disable at once?**
2. Press **YES**. The system disables the module or cartridge in one minute (or immediately, if the status is idle). Press **EXIT** to leave this display without disabling the module or cartridge.

Enabling a module or its cartridges

From the display showing the state of the module or cartridge:

1. Press **ENABLE**. The display briefly reads **Enabl ing...** The module or cartridge is immediately enabled. The display then shows the state of the module or cartridge.

Returning to the beginning

From any display showing the state of the module or cartridge:

1. Press **OK**.
2. Press until the display reads **3.Module Status**.

System Test Log

The System Test Log shows you a list of diagnostic test results, audits, event messages, and alarm codes. By using this feature you can:

- check the items in the log
- check the current alarm (if there is one)
- check when each item in the log occurred
- check the number of consecutive occurrences of an event or an alarm
- erase the log

The System Test Log holds a maximum of 20 items. You should check and record these items at regular intervals. Erase the log after dealing with all the items.

Checking the items in the log

Start with the display reading **3.Module Status:**

1. Press . The display reads **4.Sys Test Log.**
2. Press . The display reads **Start of new log.** (If there is no log entry, the display reads **Log is empty** and returns to **4.Sys Test Log.**)
3. Press or . The display shows a log item.
4. Write down the item on the System Test Log record.
5. If the log item is an event message or an alarm code, refer to the Event messages section or the Alarm codes section in this chapter.
6. Repeat steps 3, 4, and 5 until you have recorded all the items.

Checking the current alarm

If you want to quickly check the highest severity alarm before viewing all the log items, start with the display reading

Start of new log or **Start of log**:

1. Press **ALARM**. The display shows an alarm code if there is a current alarm.
If there is no current alarm, the display reads
No current alarm and then **Start of new log** or
Start of log.

2. Press **OK** to return to the display **Start of log**.

All alarms are recorded as items in the System Test Log.

Checking when each item in the log occurred

Start with any display showing a log item:

1. Press **TIME**. The display briefly shows the date and time.
2. Write the date and time on the System Test Log record.

Checking the number of consecutive repetitions of an event or alarm

If **REPEAT** appears under a display showing a log item:

1. Press **REPEAT**. The display shows the number of consecutive times the event or alarm occurred.

Erasing the log

Start with the display reading **Start of new log** or
Start of log:

1. Press **ERASE**. The display reads **Erase log?**.
2. Press **YES**.
If no new items have been added since the list was entered, the log is erased and the display reads **Log is empty**.
OR
If new items have been added since the list was entered, the display reads **Log has changed**.
3. If the display reads **Log has changed**:
Press **SHOW** show the new log.
OR
Press **EXIT** to return to **4. Sys Test Log**.

System Administration Log

The System Administration Log keeps a record of administrative events such as system initializations, Configuration sessions in which a change was made, invalid password attempts, and password changes. By using this feature you can:

- check the items in the log
- erase the log
- check when each item in the log occurred

The System Administration Log holds a maximum of ten items. Erase the log after dealing with all the items.

Checking the items in the log

Start with the display reading **4.Sys Test Log**:

1. Press . The display reads **5.Sys Admin Log**.
2. Press . The display reads **Start of new log**. (If there is no log entry, the display reads **Log is empty** and returns to **5.Sys Admin Log**.)
3. Press or . The display shows a log item.
4. Write down the item on the System Administration Log record.
5. Repeat steps 3 and 4 until you have recorded all the items.

Checking the current alarm

Start with the display reading **Start of new log** or **Start of log**:

1. Press **ALARM**. The display shows an alarm code if there is a current alarm. If there is no current alarm, the display reads **No current alarm** and then reads **Start of log**.
2. Press **OK** to return to the display showing **Start of log**.

Checking when each item in the log occurred

Start with any display showing a log item:

1. Press **TIME**. The display shows the date and time.
2. Write the date and time on the System Administration Log record.

Erasing the log

Start with the display reading **Start of new log** or **Start of log**:

Press ERASE. The display reads **Erase log?**.

3. Press YES. If no new items have been added since the list was entered, the display reads **Log is empty**.

OR

If new items have been added since the list was entered, the display reads **Log has changed**.

4. If the display reads **Log has changed**, press SHOW to show the new log.

OR

Press EXIT to return to **5.Sys Admin Log**.

Network Log

The Network Log keeps a record of events and alarms that are specific to the T1 network interface. You can:

- check the items in the log
- erase the log
- check when each item in the log occurred

The Network Log holds a maximum of twenty items. Erase the log after dealing with all the items.

Checking the items in the log

Start with the display reading **5.Sys Admin Log**:

1. Press . The display reads **6.Network Log**.
1. Press . The display reads **Start of new log**. (If there is no log entry, the display reads **Log is empty** and returns to **6.Network Log**.)
2. Press or . The display shows a log item.
3. Write down the item on the Network Log record.
4. Repeat steps 3 and 4 until you have recorded all the items.

Checking the current alarm

Start with the display showing **Start of new log** or **Start of log**:

1. Press **ALARM**. The display shows an alarm code if there is a current alarm.
If there is no current alarm, the display reads **No current alarm** and then **Start of log**.
2. Press **OK** to return to the display **Start of log**.

Erasing the log

Start with the display reading **Start of new log** or **Start of log**:

1. Press ERASE. The display reads **Erase log?**.
2. Press YES. If no new items have been added since the list was entered, The display reads **Log is empty**.

OR

If new items have been added since the list was entered, the display reads **Log has changed**.

3. If the display reads **Log has changed**, press SHOW to show the new log.

OR

Press EXIT to return to **6. Network Log**.

Checking when each item in the log occurred

Start with any display showing a log item:

1. Press TIME. The display shows the date and time.
2. Write down the date and time on the Network Log record.

Alarm codes

The Norstar KSU generates alarm codes after system disconnections or after certain anomalies in system operation. All alarm codes appear at the Alarm telephone and in the System Test Log of a Maintenance session. The following figure shows an alarm code appearing on a Norstar Alarm telephone display.

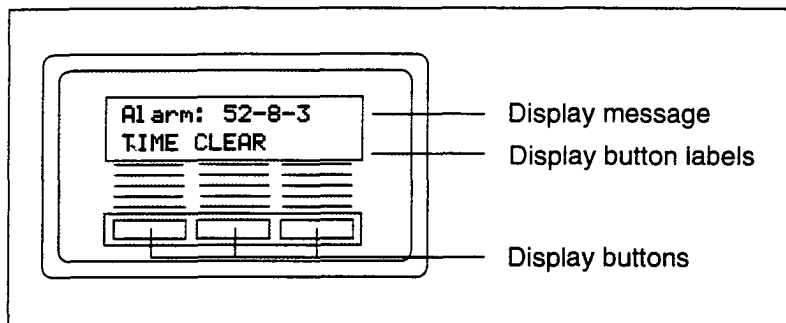

Tips

The Alarm telephone is assigned in 5. Miscellaneous of Configuration programming.

Alarms have a higher severity than events. Attend to alarm codes before event messages.

If you see an alarm code

1. Write the alarm code on the System Test Log record.
2. Determine the cause of the alarm from the following table.
3. Follow Alarm troubleshooting procedures in this chapter.
4. Press TIME to see when the alarm occurred.
5. Press CLEAR to clear the alarm.

An alarm code may not be displayed until two minutes after it has been triggered. If the KSU is powered off when the alarm is triggered, the alarm code is not displayed until two minutes after the KSU is powered on.

For a complete list of Norstar alarms, consult the *Norstar Alarm & Event Code Manual*.

Displays

Example display	Meaning	Possible causes
Alarm: 10	All KSU devices disconnected.	The last device on Norstar bus 1 (port numbers 101-124) has been removed. A 25-pair cable was disconnected from the KSU. There is an internal KSU fault.
Alarm: 40 Alarm: 41 Alarm: 42 Alarm: 43 Alarm: 44 Alarm: 45 Alarm: 46 Alarm: 47	There is a problem with the T1 signal	The cable connecting the DTI to the network termination point or external CSU has been disconnected. There is a problem with the T1 signal from the network.
Alarm: 50-X	All devices on SM disconnected.	The last device on Norstar bus X (port numbers X01-X16) has been removed. The 25-pair cable was disconnected from the SM. The fiber cable from the SM to the KSU has been disconnected. The SM was powered down.
Alarm: 51-X	Trunk Module disconnected.	All Trunk Cartridges have been disconnected from the TM on DS-30 port X. The TM was powered down. The fiber cable from the TM to the KSU has been disconnected.
Alarm: 52-X-Y	TC disconnected from TM	Trunk Cartridge Y on DS-30 port X has been disconnected from the TM.
Alarm: 61-X-Y	Incompatible Trunk Cartridge	Trunk Cartridge Y on DS-30 port X cannot operate with the Trunk type assigned to it in Configuration.

220 / Alarm codes

Alarm: 62-X-Y	Unsupported Auto-answer setting (Loop Start TCs)	Trunk Cartridge X on DS-30 port Y does not support the auto-answer setting.
Alarm: 63-Z	No available DTMF receivers	DTMF receivers are busy, not working properly, or have not been installed.

"X" = DS-30 port number (1-8)

"Y" = Trunk Cartridge number (numbered from left to right)

"Z" = Trunk port number

Alarm troubleshooting

Refer to the previous table before following these procedures.

Alarm: 10

1. Check to see if there is a device connected to the KSU (that has a port number beginning with the number "1").
2. If there are no devices connected to the KSU, connect one and then press **CLEAR**.
3. If there are any devices connected to the KSU, check all the wiring associated with the devices.
4. Refer to the section in the Troubleshooting chapter entitled KSU down.

Alarm: 40 to Alarm: 47

1. Check the System Network Log for events in the range 315-336 to verify the frequency of the alarms.
2. Refer to Digital Trunk Interface trouble in the Troubleshooting chapter.

Alarm: 50-X

1. Check that there is a device connected to the Station Module (that has a port number beginning with a number from three to eight).
2. If there are no devices connected to the Station Module, connect one and then press **CLEAR**.
3. If there are any devices connected to the Station Module, check all the wiring associated with the devices.
4. Refer to the section in the Troubleshooting chapter entitled Station Module down.

Alarm: 51-X

1. Check the wiring from the KSU to the TM.
2. See Trunk Cartridge trouble in the Troubleshooting chapter.
3. Refer to Trunk Module down in the Troubleshooting chapter.

Alarm: 52-X-Y

1. Follow the procedure in Trunk Cartridge trouble in the Troubleshooting chapter.
2. If the problem persists, replace Trunk Cartridge Y on DS-30 port X. (Refer to the previous table for the definition of "X" and "Y").

Alarm: 61-X-Y

1. Check that the proper Trunk Cartridges are inserted in the proper slots of the KSU or Trunk Module.
2. Enter Configuration programming and look under the **1. Trk/Line Data** heading. Check that the Trunk Cartridge type is correctly configured. Check that the Trunk mode and Answer mode settings do not conflict for every line connected to Trunk Cartridge Y. If Trunk mode is set to unsupervised, Answer mode must be set to manual.

OR

Install a Trunk Cartridge in slot Y that matches the type of trunk you have configured.

Alarm: 62-X-Y

1. Check that the proper Trunk Cartridges are inserted in the proper slots of the Trunk Module.
2. Enter Configuration programming and look under the **1. Trk/Line Data** heading. Check that the Trunk mode and Answer mode settings do not conflict for every line connected to Trunk Cartridge Y. If Trunk mode is set to unsupervised, Answer mode must be set to manual.

Alarm: 63-Z

1. Check that you have the required E&M Trunk Cartridges (maximum of one for every two auto-answer loop start lines installed in a Trunk Module).
2. Enter Configuration programming and look under the **1. Trk/Line Data** heading. Check that the Answer mode is correct for all the loop start lines.
3. Make sure that all of your E&M trunks installed in a Trunk Module are configured as E&M or DTMF (whichever applies) so that the system knows the receivers are there.
4. If the problem persists, an E&M Trunk Cartridge may be malfunctioning. Replace one E&M Trunk Cartridge at a time until the problem is resolved.

Event messages

Event messages appear as items in the System Administration Log or the System Test Log of the Maintenance session. Most of these event messages can only be caused by an unusual combination of events, and should rarely occur.

Each event is assigned a severity number. An "S" preceding this number, "S4" for example, may appear in the event message. "S8" is the most severe. If the Log is full, new event messages with a higher severity number replace existing event messages of a lower severity. For this reason, you should check event messages at regular intervals. You can then deal with all messages before they are replaced.

For a complete list of Norstar events, consult the *Norstar Alarm & Event Code Manual*.

Dealing with event messages

For every event message that you see:

1. Record the event on the appropriate Maintenance record.
2. Consult the next section entitled Significant event messages.
3. To see if the event caused the Norstar system to automatically restart, consult the subsequent section entitled Complete list of event numbers.

Significant event messages

The table on the next page lists event messages that are relevant to Maintenance activities. The time that the message is recorded is also provided.

Displays

Event message		The event message is recorded when...
Evt: 210-YYYZ	S4	Loopback test YYY on Trunk Cartridge Z has been started
Evt: 211-YYYZ	S4	Loopback test YYY on Trunk Cartridge Z has been stopped
Evt: 220-3546	S4	the System Administration Log has been cleared by the DN (3546 in this case)
Evt: 221-3546	S4	the System Test Log has been cleared by the DN (3546 in this case)
Evt: 222-3346	S5	the DN (3546 in this case) enters the debugging facility that is password protected
Evt: 255	S9	administered mode is not supported by the cartridge plugged into the slot
Evt: 263-302	S8	the KSU takes the E&M line on port 302 out of service because the far end did not respond to a disconnect signal
Evt: 264-302	S1	the E&M line on port 302 is returned to service after the far end finally responded to a disconnect signal (see Evt:263)
Evt: 265-302	S7	the E&M line on port 302 did not receive an expected wink signal or delay dial signal from the far end
Evt: 268-07	S8	Dialing filter 07 has lost data due to a fault in the system memory
Evt: 269-3546	S8	the Line/set filter for the DN (3546 in this case) has lost data due to a fault in the system memory
Evt: 299	S1	the system powers up after a power failure
Evt: 400	S9	Startup programming is performed using Feature <input type="text"/> * * S T A R T U P
Evt: 407	S2	there are no more codes for Speed Dial numbers
Evt: 408	S2	there is no more memory for Speed Dial codes

Significant event messages (continued)

Event message		The event message is recorded when...
Evt: 412-3546	S5	the Installer password has been changed by the DN (3546 in this case)
Evt: 413-3546	S3	the Administration password has been changed by the DN (3546 in this case)
Evt: 414-3546	S5	an invalid Installer password has been entered by the DN (3546 in this case)
Evt: 415-3546	S3	an invalid customer password has been entered by the DN (3546 in this case)
Evt: 416-3546	S4	Configuration programming is performed using Feature <input type="text"/> * * C O N F I G
Evt: 417-3546	S2	Administration programming is performed using Feature <input type="text"/> * * A D M I N
Evt: 418	S7	a DN change is successful
Evt: 419	S2	the time setting has been changed
Evt: 421	S8	a DN change failed
Evt: 422-3546	S6	a length change by the DN (3546 in this case) has been requested
Evt: 423-3546	S6	an individual DN change has been requested by the DN (3546 in this case)
Evt: 441	S2	a timeout occurred while waiting for ANI or DNIS digits to be received
Evt: 442	S5	a timeout occurred while waiting for ANI or DNIS digits to be received
Evt: 822	S8	Alarm code 63 is sent because there are no DTMF receivers for an incoming call
Evt: 883	S4	an invalid dial pulse signal was received by the DTI

Displays

You should rarely see any event messages that are not described in the section entitled Significant event messages. If you do see one of these event messages, the Norstar system has followed its normal recovery from an unusual combination of system events. Although the problem is not a serious one, repeated occurrences of the event number should be reported as soon as possible.

As a result of some events, the Norstar system automatically restarts itself. The table on the next two pages lists all the event numbers and tells you which of these events are associated with Norstar system restarts.

Most of these events are recorded in the System Test Log. The few exceptions to this are recorded in the System Administration Log, as indicated.

Event Message	System Restart	Event Message	System Restart
101-106	Yes	285-298	Yes
107	No	299	No
108-112	Yes	400 (Admin log)	Yes
113	No	401-403	No
114-116	Yes	405-411	No
117	No	412-419 (Admin log)	No
118-120	Yes	421-423 (Admin log)	No
121-123	No	424-425	No
124-125	Yes	426-430	Yes
126-129	No	431	No
130	Yes	432	Yes
131-132	No	433	No
133-134	Yes	441-442	No
135-136	No	600-602	Yes
137	Yes	603-613	No
138-150	No	614	Yes
151	Yes	615-629	No
152	No	630	Yes
160-164	No	631-646	No
170-173	No	800-802	No
200-211	No	803	Yes
220 (Admin log)	No	804-807	No
221-222	No	808	Yes
223 (Admin log)	Yes	809	No
224	Yes	810	Yes
225-228	No	811-820	No
229 (Admin log)	Yes	823	Yes
230-235	No	824-825	No
245-248	No	883	No
250-256	No	900	No
260-271	No	940-943	No
280-283	No	950-989	No

Clock Source

Systems with digital interfaces need to synchronize to the network in order to function. Synchronization is done in a hierarchical way, where each device/switch obtains the network clock from the device/or switch above it in the synchronization hierarchy and passes the network clock to the device/switch below it in the synchronization hierarchy. The synchronization levels are referred to as strata.

Norstar systems are stratum 4E equipment and are usually used as termination points in a network.

7. Clock Source lets you designate which of the systems Digital Trunk Interfaces (DTIs) obtains the timing reference from the network, which the system synchronizes to. For each DTI, choose one of the following settings:

Primary reference - the DTI obtains the timing reference from the network, which the system synchronizes to. This is the default value for the DTI in slot D1 in the KSU.

Secondary reference - the DTI acts as a standby reference. If there are excessive errors on the primary reference T1 link, or the DTI designated as primary reference fails, this DTI will obtain the timing reference from the network, which the system synchronizes to. This is the default value for the DTI in slot D2 in the KSU.

Timing master - the DTI does not obtain timing from the network, but transmits the systems timing to equipment connected to it.

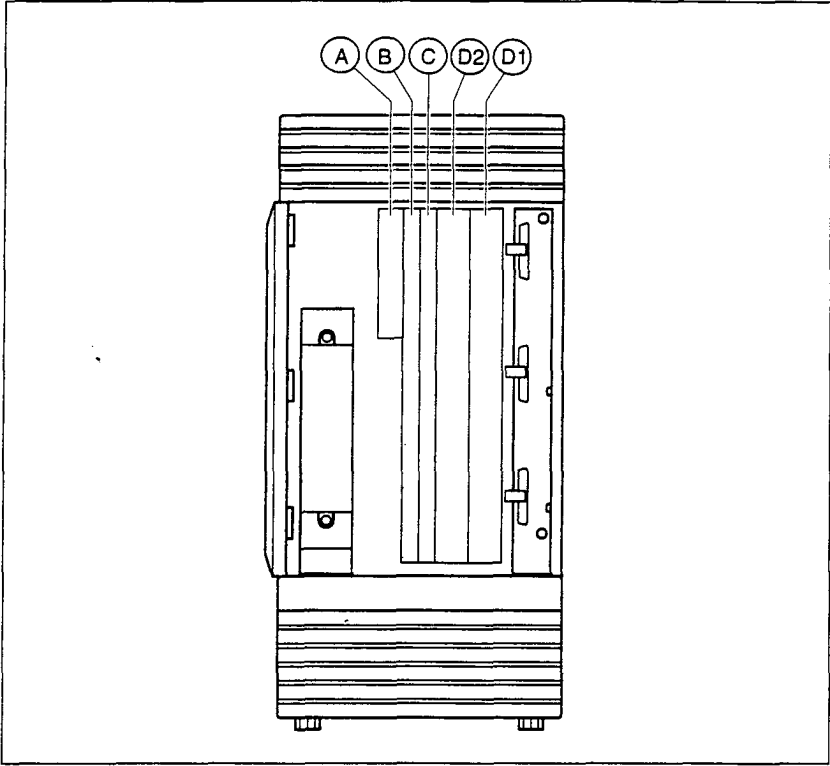

The following illustrations show some typical network configuration and the appropriate clock source settings for your DTIs.

Norstar connected directly to the T1 service provider in a T1 network

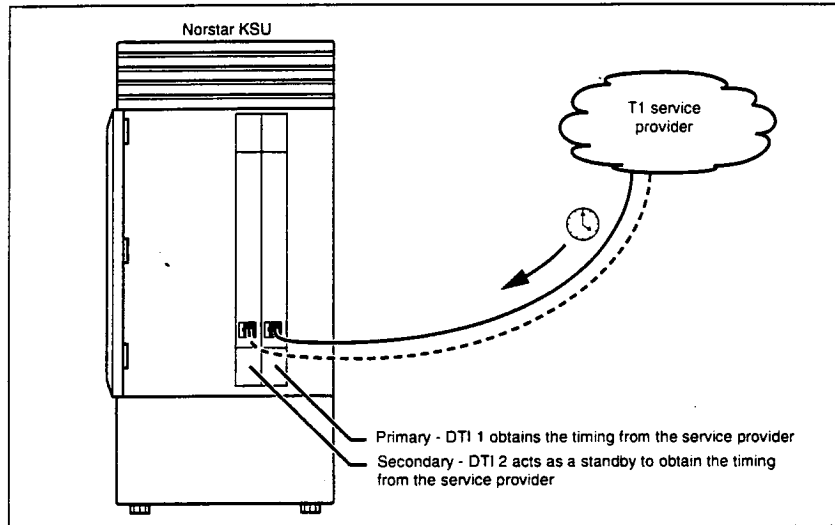

Norstar connected to another switch or MUX in a T1 network

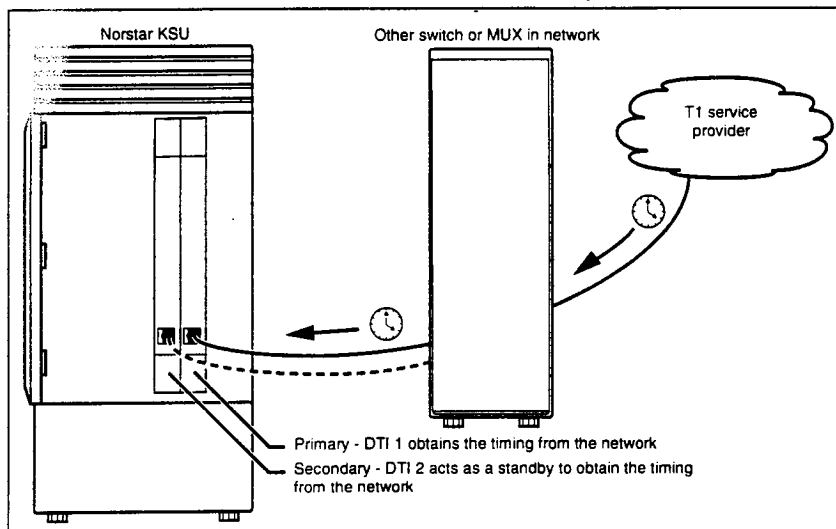

Norstar connected to another switch in a closed T1 network

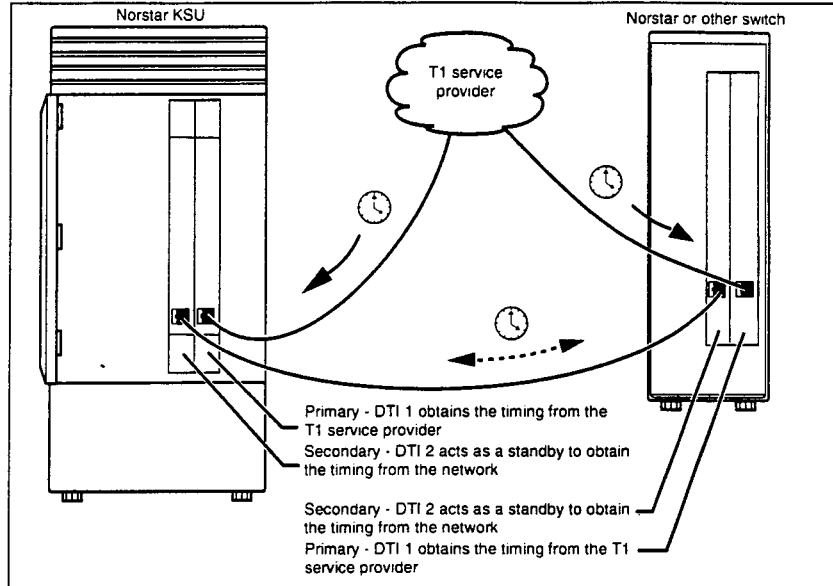

Norstar connected in a series of switches in a T1 network

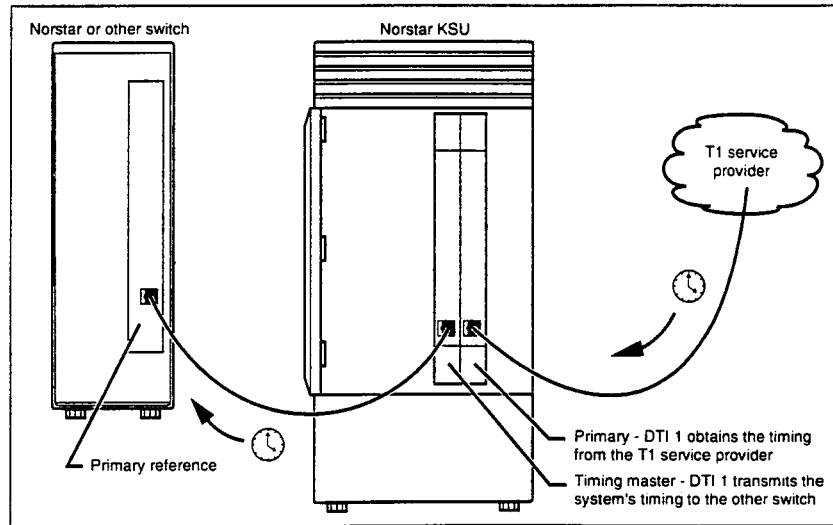

Norstar connected by a T1 link to another switch in an analog network

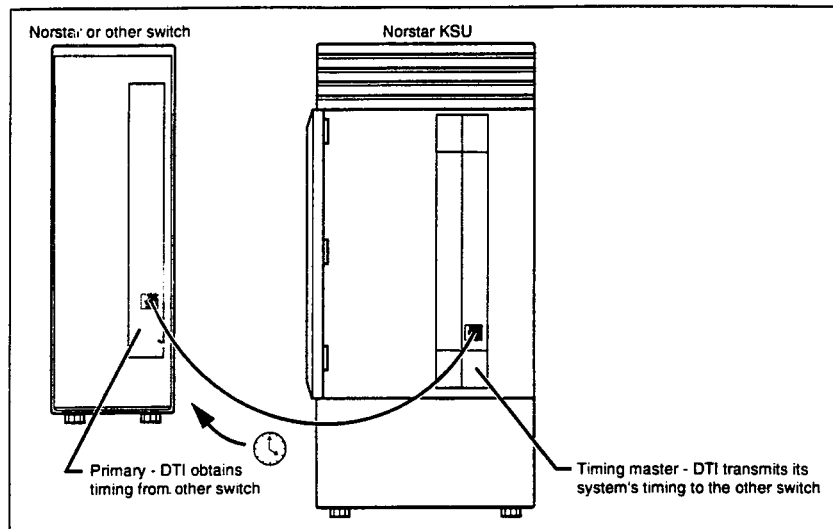

Setting the clock source for your DTIs

	<p>Changing clock source may disconnect calls</p> <p>Changing the clock source for your system may cause your system to restart itself, resulting in dropped calls. Choose a suitable time to change the clock source and use the Page feature to inform people of possible service disruptions.</p>
---	---

Start with the display reading **D. Maintenance**.

1. Press . The display reads **1. System Version**.
2. Press until the display reads **7. Clock Source**.
3. Press . The display shows the clock source setting for the first DTI (slot D1).
4. Press **CHANGE** to toggle the setting.
5. Press to change the setting for the second DTI (slot D2).
6. Press to exit or to continue in Maintenance.

Tips

In most T1 network configurations, you need one DTI in your KSU to act as a primary reference. The only application where you might not have a DTI designated as primary reference is in an analog network where your Norstar system is connected back-to-back with another switch using a T1 link. If the other switch is loop-timed to your Norstar system, your DTI can be designated as a timing master.

If your Norstar system has two DTIs, you cannot assign both DTIs as primary reference or both DTIs as secondary reference. You can only have one primary reference and one secondary reference per system.

For more information on network synchronization, consult ANSI EIA/TIA-594 Private Digital Network Synchronization, Appendix B Private Digital Network Synchronization Planning Guidelines.

Provisioning

Provisioning adds or removes individual T1 lines from service. T1 lines can be pre-provisioned even though the system is not equipped with a DTI.

Provisioning a line

Start with the display reading **7.Clock Source**.

1. Press . The display reads **8.Provisioning**.
2. Press . The display reads **Show line:**.
3. Enter the number of the line to be provisioned. The display shows the line and its current status.
4. Press **ADD** to provision a line.
5. Press **PORT** to identify the logical port number for the line. Lines cannot be provisioned from the **PORT** display. Press **LINE** to return to the line number display.
6. Press to view settings for the next line number.
7. Press until you return to **8.Provisioning**.

Deprovisioning a line

Deprovisioning all of the lines on a DTI does not disable the cartridge.

Start with the display reading **7.Clock Source**.

1. Press . The display reads **8.Provisioning**.
2. Press . The display reads **Show line:**.
3. Enter the number of the line to be deprovisioned. The display shows the line and its current status.
4. Press **REMOVE** to deprovision the line. If the line is in use, the display reads **Busy: Remove now?**. Press **YES** to deprovision the line in 60 seconds, or **CANCEL** to leave the line provisioned.
5. Press to view settings for the next line number.
6. Press until you return to **8. Provisioning**.

Loopback Tests

Norstar allows you to run four loopback tests to evaluate different aspects and segments of the T1 digital transmission path. You can only run one loopback test at a time on any one DTI.

Line loopback

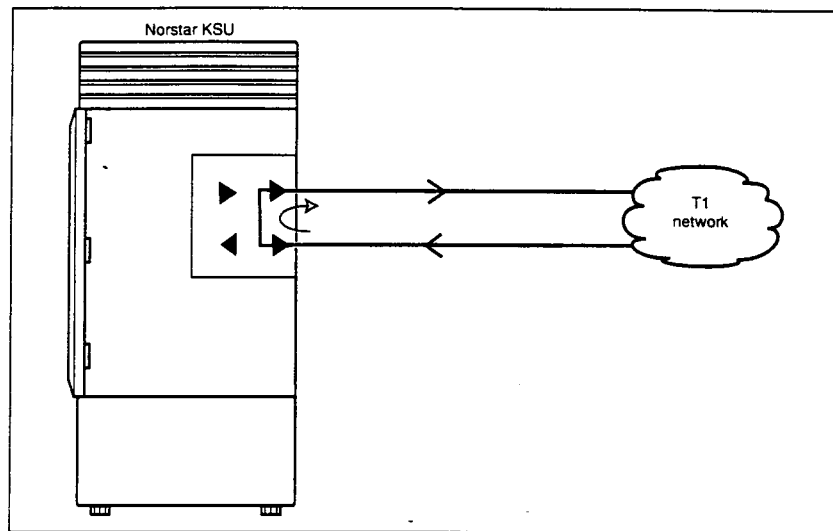

The line loopback test loops the full 1.544 Mbps signal received from the network back to the network. The looped signal is regenerated without any change in the framing format and without the removal of any bipolar violations. The line loopback test can also be invoked and stopped remotely using the in-band signal or via the facility data link (FDL) in extended super frame (ESF) format.

The line loopback test must be run in coordination with the T1 service provider. Some test patterns can cause the DTI to reset. To avoid this, start the line loopback test from your system before the T1 service provider begins their test, and stop the line loopback test from your system after the T1 service provider ends their test.

Payload loopback

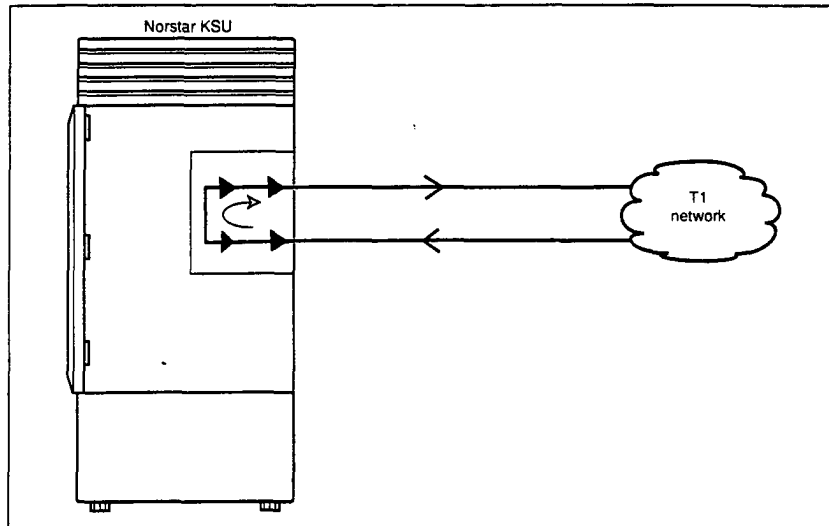

The payload loopback test loops the received information bits (192 per frame) back to the network. The payload loopback test can also be invoked and stopped remotely via the facility data link (FDL) in extended super frame (ESF) format.

The payload loopback test must be run in coordination with the T1 service provider. Some test patterns can cause the DTI to reset. To avoid this, start the payload loopback test from your system before the T1 service provider begins their test, and stop the payload loopback test from your system after the T1 service provider ends their test.

Card edge loopback

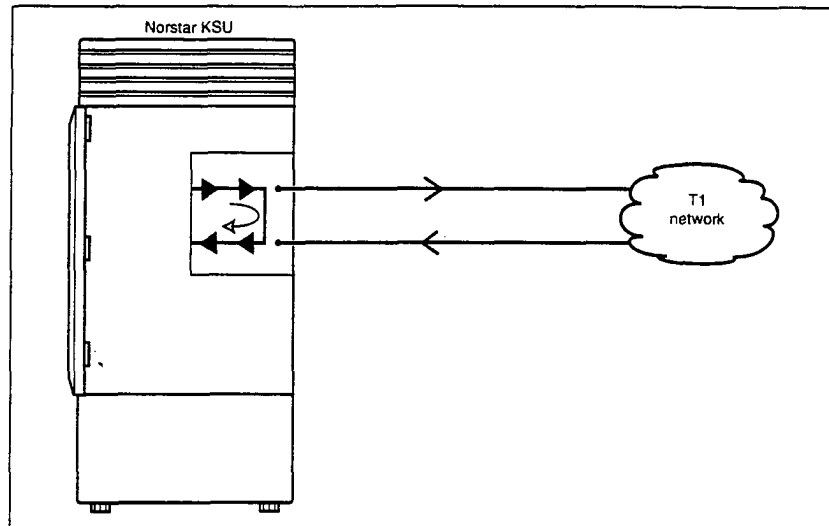

The card edge loopback test loops the outgoing signal on the DTI back to its internal received signal path. Signal paths to the external network are disconnected.

Continuity loopback

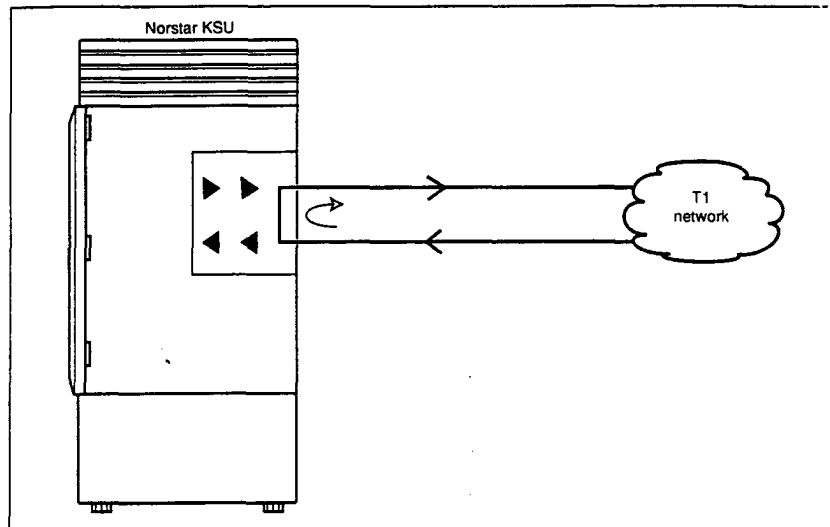

The continuity loopback test shorts the tip and ring pair of the receive signal path with the transmit signal path. This test allows you to check the metallic continuity of the external wiring.

Tests initiated from Norstar

Loopback tests, except for the continuity test, are started and stopped in Maintenance programming under the heading **9. Loopback Tests**. The continuity test is started and stopped using a button on the DTI faceplate.

Only one test at a time can be run on a trunk cartridge. You can exit Maintenance, or move on to another programming task while the loopback test is running. While the loopback test is running, the green "in Service" LED on the DTI flashes.

Tests initiated by the central office

If the internal CSU is administered on line loopback and payload loopback tests can also be invoked and stopped by the central office. In order to be able to run a payload loopback test, the DTI must be configured for extended superframe format.

Choose an appropriate time to run tests

Do not run the loopback tests while ports are being disabled or during the first two minutes after Startup programming. If you do, the tests may stop running with ports still disabled. To recover from this, unplug the KSU from the power outlet, then plug it in again.

The loopback tests disrupt service. Do not run tests when many people are using the Norstar system.

Starting a line, payload or card edge loopback test

Give notice that you are running a loopback test

Calls on all T1 lines on the DTI will be automatically dropped when a loopback test is invoked. Use the Page feature to notify people using the system that a test is about to begin and that calls will be disconnected.

Start with the display reading **8.Provisioning**:

1. Press **Next** . The display reads **9.Loopback Tests**.
2. Press **Show** . The display reads **Test:TC1 on KSU**.
3. Press **CHANGE** to toggle the setting.
4. Press **Show** . The display reads **Line loopback**. If there is a test currently running on the Trunk Cartridge, the display shows the test name followed by **running**.
5. Press **Next** until the display shows the test you want to run. Options are line loopback, payload loopback or card edge loopback.
6. Press **START** to begin the test. The display shows the test name followed by **running**. If the trunk cartridge slot is empty or occupied by an analog trunk cartridge, the display reads **Unequipped**.

7. Press until the display reads **9.Loopback Tests**. To initiate a loopback test on a second trunk cartridge, repeat steps 2 to 6 above.

Stopping a line, payload or card edge loopback test

Start with the display reading **9.Loopback Tests**:

1. Press . The display reads **Test:TC1 on KSU**.
2. Press **CHANGE** until the display shows the TC you are testing.
3. Press . The display shows the test name followed by **running**.
4. Press **STOP**. The display reads **Test stopped** and returns to **9.Loopback Tests**.

If either the KSU or the DTI is reset while a test is underway, the test will automatically stop. In this instance, no stop test event will appear in the system test log.

Starting or stopping a continuity loopback test

You start the continuity loopback test by pressing the button on the front of the DTI. Calls on all lines on the cartridge are automatically dropped when a loopback test is invoked.

	<p>Give notice that you are running a loopback test</p> <p>Use the Page feature to notify people using the system that a test is about to begin and that calls will be disconnected.</p>
---	---

The red LED light above the button remains on until the test is canceled.

Invoking a Continuity loopback test automatically cancels any other test in progress.

To stop the continuity loopback test, press the button on the DTI. The red LED light above the button turns off when the test is canceled.

CSU Stats

Each DTI is equipped with an internal channel service unit (CSU). When enabled, the internal CSU monitors the quality of the received T1 signal and provides performance statistics and diagnostic information.

DTIs must be individually programmed to establish parameters for collecting and measuring transmission performance statistics by the CSU. For information on programming your DTIs, see **1. Trunk/Line Data** in the Programming chapter.

Statistics

The CSU provides both performance and alarm statistics.

Three performance parameters are accumulated:

- errored seconds (ES-P)
- severely errored seconds (SES-P)
- unavailable seconds (UAS-P)

These parameters are defined as per TIA-547A. Errored seconds are enhanced to include control slip (CS) events.

The parameters are stored for the previous 15 minute interval, the 15 minute intervals in the last 24 hours, and the previous 24 hour interval. Only near-end performance data is recorded.

The internal CSU continuously monitors the received signal and detects four types of transmission defects:

- any active carrier failure alarms (CFA) (loss of signal LOS, out of frame OOF, alarm indication signal AIS, remote alarm indication RAI)
- the number of bipolar violations that occurred in the last minute
- any defects (loss of signal LOS, out of frame OOF, alarm indication signal AIS) that occurred in the last minute

- the number of milliseconds of short term alarms (loss of signal LOS, out of frame OOF, alarm indication signal AIS, remote alarm indication RAI) in the last minute. A short term alarm is declared when the detected defects persist for tens of milliseconds.

A carrier failure alarm (CFA) is a duration of carrier system outage. CFA types reported can be mapped to CFAs defined in TIA-547A and TR62411 as follows:

Norstar	TIA-547A	TR62411
LOS CFA	Red CFA	Red CFA
OOF CFA	Red CFA	Red CFA
AIS CFA	Red CFA	AIS CFA
RAI CFA	Yellow CFA	Yellow CFA

The criteria for declaring and clearing the alarms is selectable to meet those in TIA-547A or TR64211.

Checking the performance statistics

To check the performance statistics, start with the display reading **10. CSU Stats:**

- Press **Show**. The display reads **Show TC:**. (If the KSU is not equipped with DTIs, or if both cartridges have their internal CSU setting programmed to off, the display reads **Unequipped.**)
- Press **1** or **2** depending on which Trunk Cartridge you are checking. The display reads **Error free:** followed by the percentage of error free seconds in the current 15 minute interval.
- Press **Next**. The display shows the date and time that the system began collecting statistics.
- Press **Next**. The display reads **Performance stats.**
- Press **Show** to view the performance stats. The display reads **Current interval.**

6. Press to display the duration of the current interval.
OR
Press until the display shows the type of interval statistics you want to check. Options are:
 - **15 min intervals** for intervals in the last 24 hours, numbered from the most recent (01) to the oldest (96). Press , then enter an interval number, or press to view the most recent interval. The display shows the start time of the interval.
 - **24 hour summary** for an overall summary of the previous 24 hours. Press to display the number of intervals in the summary.
7. Press . The display reads **ES:** followed by the number of errored seconds.
8. Press . The display reads **SES:** followed by the number of severely errored seconds.
9. Press . The display reads **UAS:** followed by the number of unavailable time seconds.
10. Press until the display reads **Performance stats.**

Checking the CSU alarms

To check the CSU alarms, start with the display reading **Performance stats.**

1. Press . The display reads **Alarm stats.**
2. Press . The display shows either **No active alarms** if there are no alarms, or **Active alarms** if alarms are present.

Checking active alarms

Start with the display reading **Active alarms.**

1. Press . The display shows the first active alarm.
2. Press or to cycle through the complete list of active alarms.
3. Press to return to **Active alarms.**

Checking carrier failure alarms

Start with the display reading **No active alarms** or **Active alarms**.

1. Press . The display reads **CFA alarms**.
2. Press . The display reads **LOS CFA history**, **DOF CFA history**, **RAI CFA history** or **AIS CFA history**.
3. Press until the display shows the type of alarms you wish to view.
4. Press . The display shows the first history item and the time that the alarm started.
5. Press and to move through the history items.

Checking bipolar violations

Start with the display reading **No active alarms** or **Active alarms**.

1. Press until the display reads **Bipolar violat'n**.
2. Press . The display shows the number of bipolar violations that occurred in the last minute.

Checking short term alarms

Start with the display reading **No active alarms** or **Active alarms**.

1. Press until the display reads **ShortTerm alarms**.
2. Press . The display shows the first type of short term alarm and the number of milliseconds (not necessarily contiguous) it was active in the last minute.
3. Press and to move through the short term alarms.

Checking Defects

Start with the display reading **No active alarms** or **Active alarms**.

1. Press until the display reads **Defects**.
2. Press . The display shows the first type of defect and the number of milliseconds (not necessarily contiguous) the hardware reported it active in the last minute.
3. Press and to move through the defects.

Resetting all statistics

Start with the display reading **Alarm stats**:

1. Press . The display reads **Reset all stats?**.
2. Press **YES** to erase all the current statistics and begin collecting statistics again.

Maintenance records

Maintenance records are tables used to record information you have obtained while running a Maintenance session.

Before you begin, photocopy the tables in this section.

Recording information on the Maintenance records

To use the following records, do the following:

1. While running a Maintenance session, enter the information on a photocopy of the appropriate Maintenance record.
2. Return the completed records to your Norstar distributor.

Version number record

The Maintenance session tells you the software versions of the System Processor (SP), and devices connected to the Norstar system. Use the following table to record these version numbers when you run a Maintenance session. You can check the SP version number under the heading **1. System Version**. Device version numbers are found under the heading **2. Port/DN Status**.

Version Numbers

1. System Version	2. Port/DN Status
SP:	Device:
	Device:
	Device:
	Device:
	Device:
	Device:
	Device:
	Device:
	Device:
	Device:
	Device:
	Device:
	Device:
	Device:
	Device:
	Device:
	Device:
	Device:
	Device:
	Device:
	Device:
	Device:
	Device:

Specifications

Norstar system

Service tone cadences

Tone	Cadence (seconds)
Busy	0.5 on / 0.5 off
Expensive Route	0.3 on / 0.3 off (3 bursts)
Overflow	0.25 on / 0.25 off
Ringback	2.0 on / 4.0 off
Confirmation	1.0 on / 1.0 off (3 bursts followed by no tone)
Recall	1.0 on / 1.0 off (3 bursts followed by steady tone)
Ring splash	0.2 on (1 burst)

Power specifications

Characteristic	KSU	TM	SM
Voltage V ac	110-120	110-120	110-120
Current A rms (max)	2.6	1.75	1.0
Frequency Hz	47-63	45-70	45-70
Crest factor	4.0	4.0	4.0

Telephone loop specifications

Characteristic	Value
Loop resistance	64 Ω (300 m of 0.5 mm wire or 1000 ft of 24 AWG wire)
Loop length	300 m (1000 ft) without station auxiliary power supply 790 m (2500 ft) with station auxiliary power supply
Minimum voltage at telephone	10 V dc
Current at telephone (idle)	45 mA nominal
Current at telephone (active)	80 mA maximum

Electrical requirements

Characteristic	Spec/Value
Electrostatic discharge	
KSU and telephones	IEC 801-2 severity level 3 maximum of 15 kV with a 300 Ω / 150 pF probe
Connectors	IEC 801-2 severity level 2
Radiated immunity	maximum of 5 V/m from 100 kHz to 1 GHz
Conducted immunity	maximum of 3 V rms from 0.1 MHz to 30 MHz

Environmental requirements

Characteristic	Spec/Value
Operating temperature range	0°C to 50°C (32°F to 122°F) IEC. 68-2-1 Tests Ad and IEC 68-2-2, Method A
Storage temperature range	-50°C to 70°C (-31°F to 158°F) IEC. 68-2-2 Test Bd
Humidity above 34°C (93°F)	5% to 95% (non-condensing) <52 mbar of water vapor pressure

**Digital Trunk Interface
Network interface**

Characteristic	Spec/Value
Physical	RJ48C 8-pin modular jack
Line rate	1.544 +/- 32 Mbps
Framing	Superframe/extended superframe*
Line code	AMI/B8ZS*
Impedance	100 Ω

* These values are set in Configuration programming. See the Programming chapter for details.

DSX1 operation

Characteristic	Value
Pre-equalization	0-700 ft *

* This value is set in Configuration programming. See the Programming chapter for details.

CSU operation

Characteristic	Spec/Value
Line build out	0, 7.5 or 15 dB*
Input dynamic range	0 to -26 dB (typical)
Performance reporting	Simultaneous support of TR 54016 or TIA-547A
Line loopback support	Remote activation/deactivation via <i>in-band code or FDL as per TR 54016 or TIA-547A</i>
Payload loopback support	Remote activation/deactivation via FDL as per TR 54016 or TIA-547A
Carrier failure alarms (CFA)	Alarm indication signal (AIS), Red Yellow

* This value is set in Configuration programming. See the Programming chapter for details.

Synchronization performance

Characteristic	Spec/Value
Stratum	4E

Digital trunk signaling support

Types	Options
Loop Start with answer and disconnect supervision	OSI interval* Pulse/DTMF dialing*
E&M	Immediate start (Pulse dialing only), Wink start, Delay start or ring-down tie line* Pulse/DTMF dialing*
DID	Immediate start (Pulse dialing only), Wink start or Delay start* Pulse/DTMF dialing*

* These values are set in Configuration programming. See the Programming chapter for details.

Local test support

Characteristic	Value
Monitor jack	Bridging via Bantam jack
Line loopback	activate/deactivate via maintenance*
Payload loopback	activate/deactivate via maintenance*
Card edge loopback	activate/deactivate via maintenance*
Continuity loopback	activate/deactivate via push button on faceplate*

* See Loopback Tests in the Maintenance chapter for details on running these tests.

Upgrading your system

Upgrading your hardware

KSU

If you have a Norstar system with a Modular 8X24 Key Service Unit (KSU), you can replace your KSU with the new 0X32 KSU.

Trunk and Station Modules

If you are not adding digital T1 trunks to your system, you may reuse your existing Trunk and/or Station Modules with the 0X32 KSU. You will need to replace your copper Expansion Cartridge with a new one designed for the 0X32 KSU.

If you are adding digital T1 trunks to your system, you must replace your Trunk and/or Station Modules with the new modules that have fiber connectors, and use a new fiber Expansion Cartridge in the KSU. You can reuse your old Trunk Cartridges in the new Trunk Module with fiber connectors.

The following table shows which cartridges are compatible with which KSUs and Trunk Modules.

Module/Cartridges	Modular 8X24		0X32	
	KSU	TM	KSU	TM
Feature Cartridge - 2 piece	√			
Feature Cartridge - 1 piece			√	
Expansion Cartridge 2-port copper - NT5B26GA-93	√			
Expansion Cartridge 6-port copper - NT5B27GA-93	√			
Expansion Cartridge slim 2-port fiber - NTBB02GA-93			√	
Expansion Cartridge slim 6-port fiber - NTBB06GA-93			√	
Expansion Cartridge 2-port copper - NTBB03GA-93			√	
Expansion Cartridge 6-port copper - NTBB07GA-93			√	
Loop Start TC - NT5B40GA-93		√		√
Loop Start TC - NT7B75GA-93		√	√	√
CI TC - NT5B41GA-93		√	√	√
E&M TC - NT5B38GA-93		√		√
DID TC - NT5B37GA-93		√		√
DTI - NT7B74GA-93			√	
Services Cartridge - NTBB24GA-93			√	

If you are upgrading your KSU and adding digital T1 trunks to your system:

1. Verify your system programming, and update your *Programming Record*.
2. Follow the procedures outlines in the Installation chapter for installing a new system.

If you are upgrading your KSU, but not adding digital T1 trunks:

1. Verify your system programming, and update your Programming Record.
2. Remove power from your system.
3. Disconnect the 50-pin connector for telephones from the KSU.
4. Disconnect the 50-pin connector for external lines and auxiliary equipment from the KSU.
5. If your system includes Trunk Modules and Station Modules with DS-30 copper connectors, disconnect the DS-30 copper connectors from the Expansion Cartridge.
6. Remove any cables from the KSU cable trough.
7. Remove the KSU and wall-mount bracket from the wall.
8. Install the new KSU following the procedures in the Installing the hardware chapter.
9. If your system includes Trunk Modules and or Station Modules with DS-30 copper connectors, install a compatible Expansion Cartridge with copper connectors in slot B of the KSU. The faceplate will cover slots B and C.



Do not reuse existing Expansion Cartridge

You cannot reuse your existing Expansion Cartridge in the 0X32 KSU. You must install a new Expansion Cartridge with copper connectors.

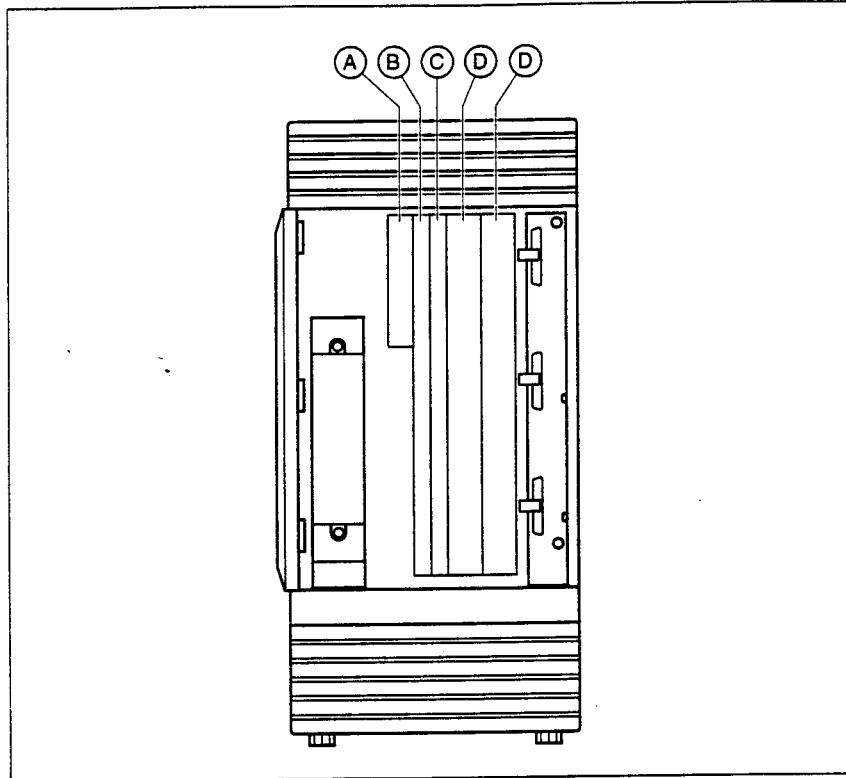

10. If you have installed a copper Expansion Cartridge in the 0X32 KSU, clip the ferrite bead that was shipped with the Expansion Cartridge onto the KSU power supply power cord.

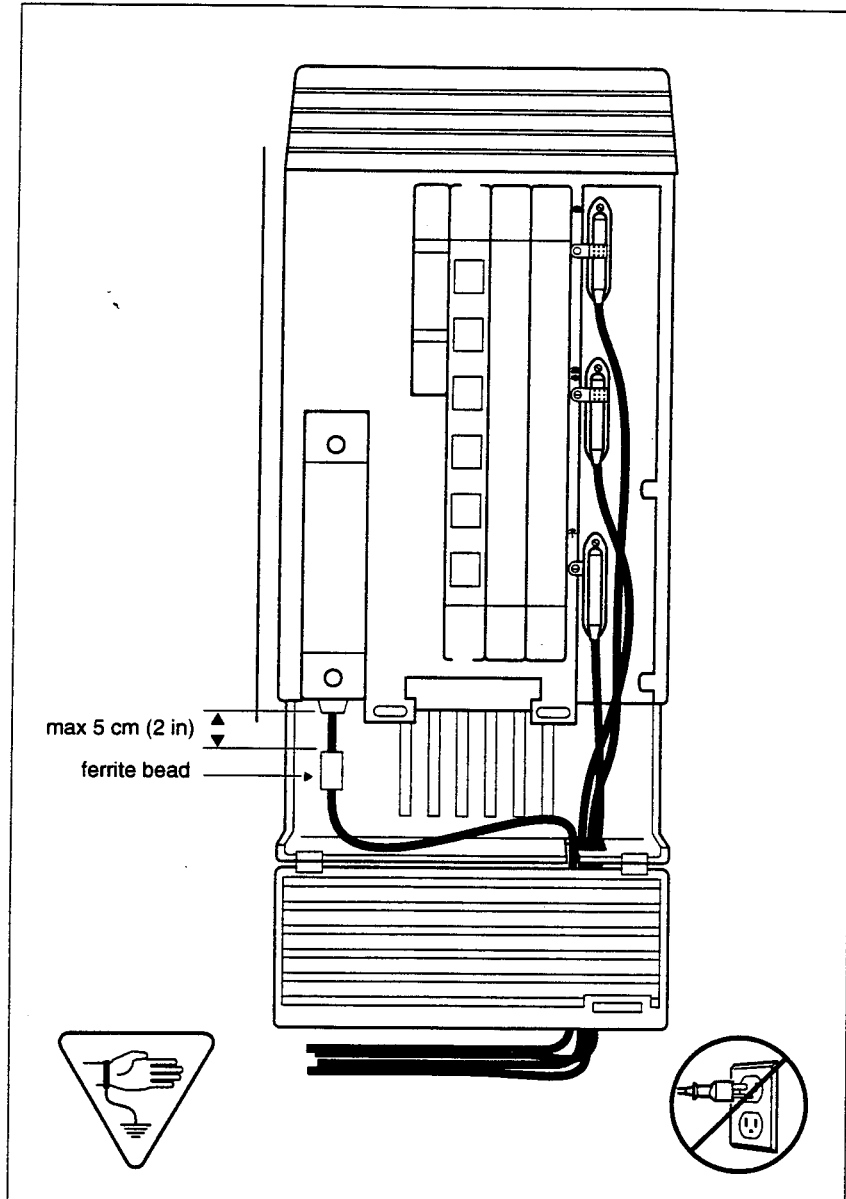



Ferrite bead required to meet EMI requirements

When using a copper Expansion Cartridge, you must install the ferrite bead on the KSU power cord to ensure that the product continues to meet FCC Part 15 Class A EMI requirements.

11. If your system includes Trunk Modules and or Station Modules with DS-30 copper connectors, reconnect the DS-30 cables to the Expansion Cartridge.
12. Reconnect your 50-pin connector for internal telephones to the internal telephone connector on the KSU.
13. Reconnect your external line and auxiliary equipment wiring according to the procedures and wiring charts in the Installing the hardware chapter. You cannot reuse your original 50-pin connector for external lines and auxiliary equipment because the pinouts have changed.



DNs on Station Modules will change

If you simply reconnect the 50-pin connector for telephones on the KSU, and leave your Station Modules telephone connectors as is, your directory numbers will change. The new KSU can accommodate 32 telephones; the old KSU connected only 24. Port numbering has been changed accordingly. To preserve existing directory numbers consult the wiring charts in Installing the hardware and change the DNs using Individual DNs in **5. System Data** in Configuration programming.

14. Power up the system.

Upgrading your software

If you have a Norstar system with a Modular 8X24 Key Service Unit (KSU), you cannot upgrade your software with the 0X32 Release 1 - T1 software release. If you want to use the new software release, you must upgrade your KSU to the new 0X32 KSU.

Since all your old programming will be lost, it is important to have an accurate record of your existing system programming so that you can plan your new system programming appropriately. Before you replace your Modular 8X24 KSU, review your system programming and update your *Programming Record*. Use this information to plan your new system programming appropriately.

Tips

If you use Norstar Manager to program your system, there is a way you can upgrade your software to the 0X32 Release 1 - T1 software release. Consult your Norstar Manager documentation for details.

264 / Upgrading your system

Glossary

A

Access code: A sequence of characters used to gain entry into any type of Norstar system programming.

Administration: A programming section that lets you assign and maintain certain settings on the Norstar system. Administration programming is performed by the system coordinator.

Administration access code: To access Administration programming, press

Feature * * A D M I N .

You will be asked for an Administration password.

Administration password: A one-to six-digit password that prevents unauthorized access to Administration programming. The Administration password can be assigned and changed in Administration programming.

Alarm code: A number that appears on the alarm telephone's display, informing you that the KSU has detected a fault in the system.

Alarm telephone: A telephone that is designated to receive reports of Norstar system problems. This function is usually assigned to a prime telephone, but this can be changed in Configuration programming.

Analog Terminal Adapter (ATA): A device that permits the connection of analog telecommunication devices such as fax machines, answering machines, and single line telephones to the Norstar system. Programmed defaults for the ATA are automatically assigned by the Norstar system.

Answer button: A telephone button with an indicator that is used to monitor another telephone. The answer button indicates incoming calls destined for the other telephone. Someone working at a telephone with answer buttons (an attendant, for example) can receive all ringing and visual indication of incoming calls for other telephones, and answer those calls when necessary.

One telephone can have up to four Answer buttons. An Answer button is automatically assigned to a telephone when that telephone is assigned an Answer DN.

Answer DN: The directory number (DN) of a telephone that is monitored by an Answer button. You can assign up to four Answer DNs to a telephone in Configuration programming.

Autobumping:

Feature 8 1 5

A feature that determines what the system does with new Call Log items when your Call Log is full. When Autobumping is on, a new log entry causes the oldest entry to be deleted. If Autobumping is off, your Norstar system does not log calls when your log is full.

Autodial button: A memory button that, if programmed, provides one-touch dialing of external or internal numbers.

Autolog options:

Feature * 8 4

A feature that allows you to select the type of calls that are stored in your Call Log. You can choose to log calls that were not answered by anyone within the system, to log calls that were unanswered at this telephone but answered elsewhere in the system, to log all calls answered and not answered at this telephone, or to not have calls automatically logged.

Automatic Dial: A feature that allows you to dial without having to pick up the receiver or select a line. You must have a prime line to use Automatic Dial.

Automatic Handsfree: A feature which automatically activates Handsfree operation when you make or answer a call. Automatic Handsfree is assigned in Administration programming.

Automatic Hold: A feature that automatically places an active call on hold when you select another line. Automatic Hold is programmed in Configuration programming.

Automatic Privacy: See Privacy.

Automatic Telephone Relocation: A feature that lets a telephone retain its personal and system programming when it is plugged into a different Norstar modular jack. Automatic Telephone Relocation is enabled in Configuration programming.

Auxiliary ringer: A separate external telephone ringer or bell which can be programmed to ring when a line or a telephone rings. An auxiliary ringer may be programmed to ring only when the system is in a particular service mode.

Programming of an auxiliary ringer is done in Administration programming after the feature has been enabled in Configuration programming.

B

Background Music: A feature that lets you hear music from the speaker of your Norstar telephone. It is available only if a music source has been attached to the KSU and the feature has been enabled in Configuration programming.

Busy Lamp Field (BLF): A device with a liquid crystal display (LCD) panel of indicators that shows the status of up to 24 telephones in the Norstar system. The BLF attaches to the M7310 telephone.

Button caps: Interchangeable plastic caps that fit over the buttons of Norstar telephones. They are used to indicate the features programmed onto each programmable memory button. Button caps are either pre-printed or have clear windows that allow you to insert labels.

Button Inquiry:

Feature * 0

With this feature you can check the function of each programmable button on your Norstar telephone.

C

Call Duration timer:

Feature

A feature that lets you see how long you spent on your last call or how long you have been on your present call.

Call Forward:

Feature

A feature that forwards all the calls arriving at your telephone to another telephone in your Norstar system. To have calls forwarded outside the system, use Line Redirection.

Call Forward No Answer: A feature that forwards all calls arriving at your telephone to another designated telephone in your Norstar system after a specific number of rings. Call Forward No Answer is assigned in Administration programming.

Call Forward On Busy: A feature that forwards all calls at your telephone to another designated telephone if your telephone is busy. This feature is assigned in Administration programming.

Call Forward Override: Call Forward Override lets you call someone and ask them to stop forwarding their calls to you.

Call Information:

Feature

Call Information allows you to display information about incoming calls. For external calls, you can display the caller's name, telephone number and the line name. For an internal call, you can display the name of the caller and their internal number. You can obtain information about ringing, answered, or held calls.

Call Information Trunk Cartridge:

The Trunk Cartridge that allows you to connect loop start trunks with Call Information capability to the Norstar system.

Call Log:

Feature

Enter your Call Log to view a record of incoming calls. The log could contain the following information for each call: sequence number in the Call Log, name and number of caller, long distance indication, indication if the call was answered, time and date of the call, number of repeated calls from the same source, and name of the line that the call came in on. See Autobumping, Autolog options, and Logit for further information.

Call Park:

Feature

With this feature you can place a call on hold so that someone can retrieve it from any other telephone in the Norstar system by selecting an internal line and entering a retrieval code. The retrieval code appears on the display of your telephone when you park the call. You can park up to nine calls on the system at one time.

Call Park Callback: See Callback.

Call Park prefix: The first digit of the retrieval code of a parked call. This digit cannot conflict with the first digit of any existing DNs, Line Pool access codes, the Direct-dial digit, or the external line access code. The default Call Park prefix digit is "1". It may be set to none, in which case Call Park is disabled. Call Park prefix is assigned in Configuration programming.

Call Pickup Directed:

Feature

A feature that lets you answer a call ringing at any Norstar telephone by entering the internal number of that telephone before taking the call. Call Pickup Directed is enabled in Configuration programming.

Call Pickup Group: See Pickup Group.

Call Queuing:

Feature

If you have several calls waiting at your telephone, you can invoke the Call Queuing feature to answer them in order of priority. Priority is given to incoming calls, followed by callback and camped calls.

Callback: If you park, camp, or transfer a call to another telephone and it is not answered there, it will ring again at your telephone. How long the system will wait before Callback occurs is set in Configuration programming.

Camp-on:

Feature

A feature that lets you reroute a call to a telephone even if all the lines on that telephone are busy. To answer a camped call, use Call Queuing or select a line if the camped call appears on your telephone. Priority is given to queued calls over camped calls.

Camp timeout: The length of a delay before a camped call is returned to the telephone that camped the call. The length of delay is set in Configuration programming.

Central answering position

(CAP): An M7324 telephone that has been designated a CAP in Configuration programming. The CAP provides backup answering and can be used to monitor the telephones within a Norstar system. One or two CAP modules can be attached to a CAP to increase the number of lines it can handle.

Central answering position (CAP)

module: A module connected to an M7324 telephone and provides 48 additional buttons that can be used as autodial buttons or feature buttons. A maximum of two CAP modules can be connected to a single M7324 telephone.

Channel Service Unit (CSU): A device on the Digital Trunk Interface that is the termination point of the T1 lines from the T1 provider. The CSU collects statistics on the quality of the T1 signal. The CSU ensures network compliance with FCC rules and protects the network from harmful signals or voltages.

Class of Service (COS): The set of Norstar features and lines available to the user for a call. The Class of Service for a call is determined by the dialing filters and remote access packages assigned to the telephone in Administration programming. The Class of Service for a call can be changed by entering a six-digit Class of Service password. (Internal users cannot change their access to features with a COS password, only their dialing filters.) Class of Service and Class of Service passwords are assigned in Administration programming. See Remote Access.

Class of Service password:

Feature 6 8

A six digit code that lets you switch from your current Class of Service to one that lets you dial numbers prohibited by your current Class of Service.

Conference:

Feature 3

The Conference feature allows you to establish a three-person call at your Norstar telephone.

Configuration: A programming section that lets you assign and maintain certain settings on the Norstar system. Configuration programming is performed by an installer or customer service representative.

Configuration access code: To access Configuration programming, press Feature * * C O N F I G. You will be prompted for a Configuration password.

Configuration password: A one-to six-digit password that prevents unauthorized access to Configuration programming. The Configuration password can be assigned and changed in Configuration programming.

Contrast Adjustment:

Feature * 7

Allows you to set the contrast level of your telephone display.

Control telephone: A control telephone can place the lines for which it has responsibility in or out of a Service Mode. The direct-dial telephone is a control telephone for directing calls to the extra direct-dial telephone. A telephone is made a control telephone and has lines assigned to it in Administration programming.

COS: See Class of Service.

Cursor: A short horizontal line that appears on the Norstar telephone display to indicate that characters can be entered using the dial pad.

D

Data Communications Interface

(DCI): A Norstar device that lets you attach an RS-232 data device to the Norstar system.

Data terminal: A device such as a modem that can be used to transfer data instead of sound over a telephone network. You cannot use Norstar programming to set up such devices. See the documentation that accompanies the device.

Date: See Show Time or Time and Date.

270 / Glossary

Defaults: The settings for all Norstar features when the system is first installed. Settings are changed from their defaults in Administration programming and Configuration programming. In this manual, default settings are shown in **bold** text.

Delayed Ring Transfer (DRT) to prime: After a specified number of rings, this feature transfers an unanswered call on an external line, to the prime telephone associated with that line. This feature is activated in Configuration programming.

DID trunk: See Direct Inward Dial trunks.

DID Trunk Cartridge: The Trunk Cartridge that allows you to connect DID trunks to the Norstar system.

Dialing filter: Through a combination of restrictions and exceptions, dialing filters prevent certain telephone numbers or feature codes from being dialed. Dialing filters can be applied to lines (line filters, remote filters), to sets (set filters), to specific lines on a set (line/set filters), and to Class of Service passwords (user filters, remote filters). The Norstar system can handle up to 100 dialing filters.

Dialing Modes:

Feature * 8 2

This feature allows you to set the dialing mode of your telephone. Norstar supports three dialing modes: Automatic Dial, Pre-Dial, and Standard Dial. All three modes support on-hook dialing (meaning you can dial a call without picking up the receiver). The special features of the Automatic and Pre-Dial modes are available only when you dial on-hook.

Digital Trunk Interface: The Trunk Cartridge connects digital T1 trunks to the Norstar system.

Direct-dial: A feature that lets you dial a designated telephone in your Norstar system with a single digit. As many as five direct dial sets can be established. Each telephone in the system is assigned to one direct-dial telephone. There is a single, system wide digit for calling the assigned direct-dial telephone of any telephone. Direct-dial telephones are established in Administration programming. Telephones are assigned to a direct-dial telephone in Administration programming.

Direct-dial #: A digit used system-wide to call a direct dial telephone. The digit is assigned in Configuration programming.

Direct-dial number: The digit used to call the direct-dial telephone.

Direct Inward Dial trunk: Trunks that allow direct inward dialing from the public network to the Norstar system.

Direct inward system access (DISA): The feature that lets remote users dial directly into the Norstar system and use Norstar features. Callers will hear stuttered dial tone and will be required to enter a Class of Service password to gain access to the system. See Remote Access.

Directed Pickup: See Call Pickup Directed.

Directory number (DN): A unique number that is automatically assigned to each telephone or data terminal. The DN, also referred to as an internal number, is often used to identify a telephone when settings are assigned during programming. Default DN assignments start at 21 in a two-digit (non-expanded) system and 221 in a three-digit (expanded) system.

DISA DN: The received number assigned to the Norstar direct inward system access facility. If a caller dials a number that is assigned to the DISA DN, the caller hears stuttered dial tone and must enter a Class of Service password. Once the password is accepted, the caller hears system dial tone and can use Remote Access features. See Remote Access.

Disconnect Supervision: A setting that enables the Norstar system to detect if an external caller hangs up. Once an external caller hangs up, the Norstar system can disconnect its line. Disconnect Supervision is enabled in Configuration programming.

Display: A liquid crystal display (LCD) on the Norstar telephone that guides you through feature operation and programming.

Display button: The Norstar M7310 telephone and M7324 telephone are each equipped with three buttons located directly beneath the display. During feature operation or programming, some or all of these buttons may be used to provide further options. If an option is available, it is shown in the bottom row of the two row display, directly above the corresponding display button. Display buttons are represented in this manual as underlined capital, e.g. OK.

DN: See Directory number.

Do Not Disturb:

Feature

A feature that stops calls from ringing at your telephone. Only Priority Calls will ring at your telephone. A line button will flash when you receive a call, but the call will not ring.

DTI: See Digital Trunk Interface.

E

E&M/DISA Trunk Cartridge: The Trunk Cartridge that allows you to connect E&M trunks to the Norstar system. The E&M Trunk Cartridge also allows DISA access to the system by providing DTMF receivers for auto-answer trunks.

Emergency telephone: A single-line telephone (also referred to as a 500/2500 telephone) that becomes active when there is no power to the Key Service Unit.

Event message: Event messages are stored in the system log and displayed during a Maintenance session. They record a variety of events and activities in the Norstar system.

Exceptions: One component of a dialing filter. Exceptions are numbers you can dial even if they are forbidden by a more general Restriction. See Restrictions.

Expansion Cartridge: A cartridge that allows you to connect Trunk Modules and Station Modules to the KSU to expand the system's capacity for trunks and telephones. There are two Expansion Cartridge: a two-port Expansion Cartridge and a six-port Expansion Cartridge.

External call: A call to a destination outside the Norstar system.

External Call Forward: See Line Redirection.

External code: The number you dial to get an external line. By default it is 9, but this can be changed in Configuration programming. You do not always need an external code. It is primarily to support the M7100 telephone and single line telephones using an Analog Terminal Adapter.

External line: A line on your Norstar telephone used for making calls to destinations outside the Norstar system.

External music source: See Music source.

External paging: A feature you can use to make voice announcements over an externally-mounted loudspeaker connected to the Key Service Unit. The external speaker is not a Norstar component and must be supplied by the customer.

F

Feature button: Many Norstar features are invoked by pressing the Feature button followed by a feature code. The feature button is also used to exit a feature.

Feature Cartridge: A replaceable cartridge containing the Norstar features. The Feature Cartridge is inserted into the Key Service Unit.

Feature code: A number that is used to activate a particular feature.

Feature programming:

Feature * 3

Allows you to program a feature code onto a memory button.

Forward: See Call Forward.

Full Autohold (on idle line): When this feature is on, if you select an available line, and then do something that selects another line, the first line is put on hold. Full Autohold is enabled in Configuration programming.

Full Handsfree: See Handsfree.

G

Group Listening:

Feature

A feature that allows you to have others in your office hear a caller through your phone's speaker. The caller hears you only when you speak into the receiver and cannot hear other people in the office. You can cancel Group Listen for the current call. Group Listen is cancelled automatically when you hang up the Group Listen call.

H

Handsfree:

A feature you can use to make calls without using the telephone receiver. Full Handsfree is activated in Administration programming. When it is activated, a Handsfree/Mute button is automatically assigned to the telephone.

Handsfree (HF) Answerback:

When activated, this feature automatically turns on the microphone at a telephone receiving a Voice Call so that the person receiving the call can respond without lifting the receiver. It is activated in Administration programming.

Handsfree/Mute button: See Handsfree.

Headset: A head-mounted or ear-mounted telephone receiver that is used instead of the hand-held receiver. Headsets are not Norstar components and must be supplied by the customer.

Held (Line) Reminder: A Norstar telephone rings and displays the message **On hold: LINENAM** when an external call has been placed on hold for a certain period of time. The Held Line Reminder feature and Remind delay are set in Configuration programming.

HF Answerback: See Handsfree Answerback.

Hold button:

This button is used to suspend calls so that the person using the telephone can perform another task without disconnecting the caller.

Hookswitch Flash: See Link time.

Host system signaling: (Also referred to as end-to-end signaling.) Norstar telephones can access a remote system or dial a number on an alternate carrier by means of host feature activation, such as Link, Pause and Run/Stop.

Hotline: This feature automatically calls a pre-assigned number when the telephone's receiver is lifted or the Handsfree/Mute button is pressed. A Hotline number can be an internal or external number. Hotline is assigned in Administration programming.

I

IC: An abbreviation of intercom.

Incoming line group: A group of lines used for incoming calls. Incoming line groups provide a way of giving a telephone access to several incoming lines without taking up many line buttons. A line is assigned to be part of an incoming line group in Configuration programming.

Intercom button: A button that provides access to internal lines used for calls within a Norstar system and access to external lines through a line pool or external code. A telephone may be assigned zero to eight Intercom buttons. This is done in Configuration programming.

Intercom keys: See Intercom button.

Internal line: A line on your telephone dedicated to making calls to destinations inside your Norstar system. An internal line may still connect you with an external caller if you use it to access a line pool or to pick up a call using Norstar call handling features such as Call Park or Call Pickup Directed.

Internal number: A number (also referred to as a Directory Number or DN) that identifies a Norstar telephone or device.

Internal user: Someone using a Norstar telephone within a Norstar system.

K

Key Service Unit (KSU): The central hardware component in the Norstar system. The KSU has its own processor and memory, and provides a physical point of connection for the various types of devices, telephones, and expansion modules used in Norstar. The KSU can function on its own as a basic system (with 32 Norstar telephones and up to 48 external lines), or with the addition of a Trunk Module (TM) that supports more external lines, or a Station Module (SM) that supports more Norstar telephones.

L

Last Number Redial:

Feature

A feature that allows you to redial the last external number you dialed.

Least cost routing: See Routing.

Line: The complete path of a voice or data connection between one telephone (or other device) and another.

Line filter: See Dialing filter.

Line number: A number that identifies an external line. The total number of lines depends on how many Trunk Modules are installed.

Line Pool:

Feature

A group of lines used for making external calls. Line pools provide an efficient way of giving a telephone access to external lines without taking up many line buttons. A line is assigned to be part of a line pool in Configuration programming.

Line Profile: A feature you can use to review the settings that have been programmed to lines in Configuration and Administration programming. The settings cannot be changed with this feature. Line profile is available only on the M7310 and M7324 telephones.

Line Redirection:

Feature 8 4

A feature that allows you to redirect all calls on an incoming line to a destination outside the Norstar system. Once a line is redirected it cannot be answered within the Norstar system. The system may be set up to give a brief ring when a call comes in on a redirected line. This feature differs from Call Forward in two ways. It redirects only external calls (not internal calls) and it redirects calls to destinations outside the system. Call forward redirects calls only to destinations inside the Norstar system. See Call Forward.

Link:

Feature 7 1

If your Norstar system is connected to a Private Branch Exchange (PBX), you can use a Link signal to access special features. The Link signal can also be included as part of a longer stored sequence on an External Autodial button or in a Speed Dial code. The Link symbol (☎) uses two of the 24 spaces in a dialing sequence.

Logit:

Feature 8 1 3

Logit lets you manually log call information when you are connected to a call.

Long Tones:

Feature 8 0 8

A feature that lets you control the length of a tone so that you can signal devices such as fax or answering machines which require tones longer than the standard 120 milliseconds.

Loop Start Trunk Cartridge: The Trunk Cartridge that allows you to connect loop start trunks to the Norstar system.

M

M7100 telephone: A telephone with a single line display and one programmable memory button without an indicator.

M7208 telephone: A telephone with a single-line display and eight programmable memory buttons with indicators.

M7310 telephone: A telephone that has a two-line display, three display buttons, 10 programmable memory buttons with indicators, and 12 dual memory programmable buttons without indicators. An M7310 can be equipped with a Busy Lamp Field.

M7324 telephone: A telephone with a two-line display, three display buttons, and 24 programmable memory buttons with indicators. An M7324 telephone can be equipped with a CAP module.

Maintenance: A type of programming that is used to diagnose and repair problems in the Norstar system. Maintenance requires no programmable settings.

Memory buttons: Buttons that can be programmed to dial frequently used features or numbers automatically. See M7100, M7208, M7310, and M7324 telephone entries for their exact memory button configurations.

Message: A feature that allows you to send a message to another Norstar user. The Message feature also lets you know if you have any messages waiting and maintains a Message Waiting List to keep a record of your internal messages and your (external) voice mail messages.

Module: A component of the Norstar 0X32 key system. Includes the Key Service Unit, Trunk Module and Station Module.

Move Line buttons:

Feature * 8 1

A feature that allows you to move external lines to different buttons on your telephone.

Music source: A radio or other source of music can be connected to the Key Service Unit to provide music for the Music on Hold and Background Music features. A music source is not part of the Norstar system and must be supplied by the customer.

N

Names: Names can be assigned to System Speed Dial numbers, external lines, telephones, and Service Modes. This is done in Administration programming. You can use up to sixteen characters to name a System Speed Dial number, and seven characters to name a telephone, line, or Service Mode. If a Name has not been assigned, the line number or DN will appear on the display instead of a name.

O

On hold: A setting, programmed in Configuration programming, that controls whether external callers hear music, periodic tones, or silence when they are placed on hold.

Overlay: See Programming overlay.

P

Page:

Feature 6 0

A feature you can use to make announcements over the Norstar system. You can make page announcements over the telephone speakers and/or external speakers.

Page zone: An area in the office that receives internal page announcements independently of the rest of the office. Each page zone is identified by a number. Telephones are assigned to page zones in Administration programming.

Park prefix: See Call park prefix.

Park timeout: The time before an unanswered parked call is routed back to the telephone that parked it. Park timeout is in Configuration programming. See Call Park.

Password: A password is a specific sequence of digits that you enter to gain access to Norstar programming, to override dialing restrictions, or to use remote access with DISA. Passwords are also required for Startup, Configuration and Administration programming.

Pause:

Feature 7 8

A feature that enters a 1.5 second delay in a dialing sequence on an external line. This is often required for signaling remote devices, such as answering machines, or when reaching through to PBX features or host systems. The Pause symbol (Ⓟ) uses one of the 24 spaces in a dialing sequence. For pulse dialing, * inserts a 1.5 second pause into the dialing sequence.

Personal Speed Dial:

Feature * 4

Two-digit codes (71-94) can be programmed to dial external telephone numbers. Personal Speed Dial numbers are programmed for each telephone, and can be used only at the telephone on which they are programmed.

Pickup Group:

Feature 7 5

A telephone can be placed into one of nine call pickup groups. A call ringing at a telephone within a pickup group can be picked up at any other telephone within the same pickup group. A telephone is assigned to a pickup group in Administration programming.

Pool: See Line pool.

Pre-dial: A feature that allows you to enter a number and check it on your telephone display before it is actually dialed. If the number is incorrect, you can edit it. The number is dialed only when you pick up the receiver or select a line.

Prime line: The line on your telephone that is automatically selected when you lift the receiver, press the Handsfree/Mute button or use an external dialing feature. A Prime Line is assigned to a telephone in Configuration programming.

Prime Set (prime telephone): A telephone that provides backup answering for incoming calls on external lines. The prime telephone for a line will ring for any unanswered calls on that line. A prime telephone is assigned to a line in Configuration programming.

Priority Call:

Feature 6 9

If you get a busy signal when you call someone in your office, you can interrupt them for an urgent call. This feature is enabled for a telephone in Administration programming.

Privacy: This feature determines whether a Norstar user may select a line in use at another telephone and join an established call. Privacy is enabled in Configuration programming, but can be turned on and off by users during individual calls.

Private line: See Private to.

Private network: A telephone network consisting of owned or leased telephone lines used to connect different offices of an organization independently of the public network.

Private to: A line can be assigned, in Configuration programming, to one telephone as a private line. The line cannot appear on any other telephone, except the prime telephone for that line. Private lines cannot be placed into line pools.

Programmed release:

Feature * 8 9

A feature that performs the function of the Rls button in a programmed dialing sequence.

Programming: Setting the way the Norstar system will work. Programming includes system-wide settings and individual telephone and line settings.

Programming overlay: A paper template that is placed over the top four memory buttons with indicators on the M7310 or M7324 telephone during programming. The overlay labels indicate the special function that each of the four buttons takes on in programming.

Programming reminders: Charts on which you can record some commonly-used settings from Administration programming to keep the Norstar system's records up-to-date.

Public line: An external line that can be assigned to any telephone and to many telephones. A line is assigned as Public in Configuration programming.

Public network: The regular telephone network that connects most homes and businesses.

Pulse/tone dialing: An external line setting for pulse or tone dialing. Pulse is the traditional method of dialing used by rotary-dial or push-button single-line telephones. Tone dialing allows telephones to communicate with other devices such as answering machines. Tone dialing is required to access the features that PBX systems may offer or to use another Norstar system remotely.

R

Recall: See Link time.

Receiver: The handset of a telephone.

Remind delay: A feature that causes a telephone to beep and display the message

On hold: LINENAM when a call has been on hold for a programmable period of time. This period is the Remind delay.

Remote access: The ability to dial into a Norstar system from outside the system and make use of selected Norstar features. The lines, features, and dialing capabilities available to a remote user are determined by the Class of Service. If the remote access line is answered with DISA, the user must enter a Class of Service password to gain access to the Norstar system's features.

Remote access dial filter: See Remote filter.

Remote capability: A subset of Norstar features that are available to users connected through remote access.

Remote filter: A dialing filter applied to a line in order to control which digits can be dialed during an incoming remote access call. It is the equivalent of a set filter for a remote user.

Remote paging: This feature allows remote users to use the Norstar paging feature. Access to this feature is governed by the Class of Service for the call. See Remote Access and Class of Service.

Remote User: Someone who calls into a Norstar system from a telephone outside that system and uses Norstar features or lines. See Remote Access.

Restriction service: A Service Mode service that allows you to assign alternate dialing filters to lines, telephones, lines on a particular telephone, and alternate remote filters to lines at specified times of the day and on specified days.

Restrictions: One component of a Dialing filter. Restrictions are numbers you cannot dial when that dialing filter is in effect. See Exceptions.

Ring Again:

Feature 2

A feature that can be used when you can't get through to someone on your Norstar system because their telephone is busy or there is no answer. Ring Again instructs the Norstar system to inform you when they hang up or next use their telephone.

Ring type:

Feature * 6

A feature that allows you to select one of four distinctive rings for your telephone.

Ring volume:

Feature * 8 0

A feature that allows you to set the volume at which your telephone rings.

Ringng service: A Service Mode service that allows you to make additional telephones ring at specified times of the day and on specified days.

Rls button: The Release button ends a call in the same way that hanging up the receiver does. It may also be used to end Startup, Configuration programming, Administration programming, Maintenance sessions and feature operations.

Routing: A section of configuration programming that allows you to create destination codes and define routes for calls. Routing tables allow you to provide transparent dialing in a network and can be used with the Routing service in Service Modes to provide least cost routing.

Routing service: As Service Mode service that allows you to assign alternate routes for calls that use routing during specified times of the day and specified days of the week. Routing service can be used to provide least-cost routing.

Run/Stop:

Feature * 9

A feature that creates a break point in a programmed external dialing sequence. When you press a programmed key, the system dials the number up to the run/stop. When you press it again, the system dials the digits following the run/stop.

S

Saved Number Redial:

Feature 6 7

A feature that allows you to save the number of the external call you are on (providing you dialed the call) so that you can call it again later.

Selective line redirection: See Line Redirection.

Service Modes: A feature that places one or more lines into a Service Mode. Service Modes provides three services: Ringing service, Restriction service and Routing service. Service Modes settings are assigned in Administration programming.

Set: A telephone.

Set Copy: A programming section that allows you to copy programmable settings from one telephone to another of the same type. Set Copy provides two options: duplicating System Data and User Data, or duplicating System Data only. Set Copy does not provide the same copy capability as **COPY**, which is more selective of the settings that can be duplicated.

Set filter: See Dialing filter.

Set lock (telephone lock): This feature allows you to limit the number of features that may be used or programmed at a telephone. Full set lock allows very few changes or features, Partial set lock allows some changes and features, and No set lock allows any change to be made and any feature to be used. Set lock is assigned in Administration programming.

Set Profile: A feature you can use to review the settings that have been assigned in Configuration programming and Administration programming. The settings cannot be changed with this feature. Set profile is available only on the M7310 and M7324 telephones.

Set Relocation: See Automatic Telephone Relocation.

Shift button: A small triangular button beside the dual memory buttons on the upper half of the M7310 telephone. You press the shift button to store or access features on the top half of the dual memory buttons.

Show Time:Feature

While on a call, accessing this feature lets you see the current date and time on the Norstar telephone display.

Startup programming: When a Norstar system is first installed and powered up, Startup programming must be performed before any programming can be done. Startup initializes the system programming to defaults.

Station: An individual telephone or other Norstar device.

Station Module: A module that allows you to connect up to 16 additional telephone to your Norstar system.

System coordinator: The person responsible for customizing the Norstar system through Administration programming and for helping co-workers use the Norstar system.

System Data: An option in the Set Copy function. System Data refers to the system settings that apply to all telephones and lines. System Data consists of the programmable settings from Startup programming and Administration programming. It also includes the settings programmed in Configuration programming.

System speed dial code: A Two-digit code (01 to 70) that can be programmed to dial a telephone number up to 24 digits long. System speed dial codes are programmed for the entire Norstar system in Administration programming.

System Startup: See Startup programming.

System Startup access code: To begin System Startup, press

Feature

. An Installer password is required before Startup programming can begin.

T

T1: Digital carrier system or line that carries data at 1.544 Mbps.

Tandem call: A call established when a remote user dials into the Norstar system and uses the system to place an outgoing call. The combination of the incoming and outgoing calls forms a tandem call. See Remote Access.

Transfer:Feature

A feature that lets you redirect a call to another telephone in your Norstar system, over a network or outside your Norstar system.

Transfer Callback: If a transferred call is not answered after a specific number of rings, the call will return to the telephone that made the transfer. The number of rings is assigned in Configuration programming. Transfer Callback does not apply to calls transferred externally.

Trunk: The physical connection between the Norstar system and the outside world using either the public telephone system or a private network.

Trunk Answer:Feature

A feature you can use to answer a call on any line that has an active Ringing service Service Mode, even if that line does not appear on your telephone. Trunk Answer is enabled in Administration programming.

Trunk Module: A module that allows you to install additional Trunk Cartridges in your system to provide up to 12 additional trunks.

U

Unsupervised line: A line for which disconnect supervision is disabled. If an external caller hangs up, the Norstar system does not detect the disconnection and does not hang up its line. See Disconnect Supervision.

User Data: User Data is an option in the Set Copy feature. User Data refers to the personal settings that are unique to an individual telephone, and are not programmed in Configuration or Administration programming. User Data is programmed at each telephone. These settings, for example, include Personal Speed Dial and the assignment of programmable memory buttons.

User Filter: See Dialing filter.

V**Voice Call:**Feature

A feature you can use to make an announcement or begin a conversation through the speaker of another telephone in the Norstar system. The telephone you call will not ring. Instead, the person you call will hear a beep and then your voice. Their telephone will beep periodically to remind them that their microphone is open.

Voice Call deny:Feature

A feature that prevents your telephone from receiving Voice Calls.

Voice message center: If you have subscribed to Call Display services you can receive visual Voice Message Waiting Indication, providing your telephone has a display. If you have Voice Message Waiting Indication, you can program the telephone numbers required to access up to five different Voice Message Centers. You can also program which of the five Centers is to be accessed by each specific line.

W**Wait for dial tone:**Feature

A feature that causes of sequence of numbers to pause until dial tone is present on the line before continuing to dial. The Wait for dial tone symbol (■) uses two of the 24 spaces in a dialing sequence.

Index

Symbols

2 ports busy 210

3 sets busy 210

4 lines busy 210

A

access code

line pool 26

alarm

check active alarms 243

check current 213

codes 218

CSU 243

messages 145

Network Log 216

short term 244

System Administration Log
214

telephone 145

troubleshooting 220

Alarm 10 219, 220

Alarm 40 219, 220

Alarm 41 219, 220

Alarm 42 219, 220

Alarm 43 219, 220

Alarm 44 219, 220

Alarm 45 219, 220

Alarm 46 219, 220

Alarm 47 219, 220

Alarm 50-X 219, 220

Alarm 51-X 219, 221

Alarm 52-X-Y 219, 221

Alarm 61-X-Y 219, 221

Alarm 62-X-Y 220, 221

Alarm 63-Z 220, 222

Analog Terminal Adapter

accessing external lines 148

troubleshooting 178

ANI Number 122

Answer DN's 131

answer mode 121

answer timer 116

answer with DISA 121

apply button cap labels 156

assign

Answer DN's 131

incoming line groups 130

intercom buttons 132

line pools 131

lines 129

prime line 132

ATA (see Analog Terminal
Adapter)

Auto DN

programming 145

Auto Number Identification 9,
122

auto privacy 128

auto-answer

E&M trunks 15

loop start trunk and DISA 14

Automatic Telephone Relocation
80

programming 146

testing 163

auxiliary ringer

installation 81

programming 128

troubleshooting 178

B

B1 and B2 directory numbers 61
 Background Music 143
 installation 81
 programming 82
 troubleshooting 180

BKSP 88

Busy 205

button caps

 types of 156

button defaults

 M7100 telephone 158

 M7208 telephone 158

 M7310 telephone 158

 M7324 telephone 160

C

cadence

 service tone 251

Call Handling

 programming 139

 defaults 95

Call Handling 110

call routing 24

Call Services

 defaults 102

Camp timeout delay 141

CAP (see Central Answering
 Position)

card edge loopback test 237

carrier failure alarms 241

carrier failure standard 116

cartridge

 checking the state 211

 E&M Trunk 42

 enabling 211

 Expansion 42

 installation 49, 52

 Loop Start Trunk 42

central answering position

 line assignment 130

 programming 145

Centrex template 91

 button defaults 158

Change 88

Channel Service Unit 117, 241

 alarms 243

 line build 117

 performance statistics 242

CI Trunk Cartridge

 wiring chart 69

Class of Service

 Auto DN 145

 calls answered with DISA
 144

 dialing filters 21

 security 21

Class of Service password

 auto-answer system 19

 defaults 100

 remote callers 14

 with DISA 23

Clock Source 199

clock source 228

 Digital Trunk Interface 106

 primary reference 106, 228

 sample configurations 230–
 232

 secondary reference 107,
 228

 timing master 107, 228

CO fail 116

compatibility

 modules/cartridges 258

Configuration password (see

 Installer password)

Configuration programming 85,
 110–152
 Call Handling 139
 default digits 148
 defaults 91
 entering 110
 Line Access 129
 Miscellaneous 143
 Routing 134
 System Data 150
 Trunk/Line Data 111
 connecting expansion modules
 54, 55, 56
 connecting the wiring
 to the distribution block 60
 continuity loopback test 238,
 240
 Control Circuit Interface
 emergency transfer
 conditions 74
 control telephone
 activating modes 137
 coordinated dialing plan 24
COPY 88
 copy
 line programming 112
 set programming 155
 Trunk and Line data 112
 copying programming (see **Set**
 COPY or **COPY**)
 COS (see Class of Service)
 cross connections
 E&M/DISA Trunk Cartridge
 70
 CSU (see Channel Service Unit)
 CSU Stats 241
 CSU stats 199

D

defaults
 admin password 101
 Administration 97–102
 button assignments 157
 Call Handling 95
 Call Services 102
 Class of Service passwords
 100
 Configuration 91–96
 dialing filter 98
 Direct-Dial 97
 directory number lengths
 151
 Installer password 149
 line abilities 100
 Line Access 94
 Line data 93
 Log Defaults 101
 Miscellaneous 96
 Names 97
 received number length 152
 remote access packages 98
 Routing 95
 Service Modes 101
 set abilities 99
 Startup 91
 System Data 96
 System Speed Dial 97
 template settings 91
 Time and Date 97
 Trunk Cartridge
 Configuration 91
 Trunk data 92
 Define routes 136
 DialOut 136

- delay
 - Camp timeout 141
 - Delayed Ring Transfer 140
 - Held Line Reminder 139
 - Park timeout 141
 - Transfer Callback 140
- Delay Dial signal type 121
- Delayed Ring Transfer 140
 - to prime telephone 140
- deprovisioning a line 234
- Dest codes 137
- destination codes
 - Mode 137
 - programming 137
 - Routing 137
 - Use route 138
- device
 - disabling 206
 - enabling 207
- diagnostic test results
 - System Test Log 212
- diagnostics
 - T1 signal 241
- dial mode 123
- dial tone
 - absent on external lines 172
- Dialed Number Identification 122
- dialing filter 21
 - defaults 98
 - E&M trunk 22
 - remote 22
 - Restrictions service 22
- dialing plan
 - coordinated 24
 - transparent 24
- DialOut 136
- DID (see Direct Inward Dial)
- Digital Trunk Interface 13
 - clock source 106, 228
 - continuity loopback test 240
 - LEDs 183
 - Maintenance programming 106
 - specifications 253
 - wiring chart 67
- Direct Inward Dial
 - mixed service wiring 76
 - supervisory signaling 74
 - template 9
- Direct Inward Dial template 91
 - button defaults 158
- Direct Inward Dial Trunk Cartridge
 - emergency transfer 74
 - wiring chart 73, 75
- Direct Inward Dial trunks 13
 - as prime line 18
 - incoming calls 17
 - remote access 20
- Direct Inward System Access 13, 15, 16, 18
 - DID trunk 20
 - DN 144
 - private networks 30
 - remote callers 23
- Direct-Dial
 - defaults 97
- direct-dial digit
 - programming 144
- Directed Pickup 141
 - compared to Call Pickup 141

- directory numbers
 - B1 and B2 61
 - changing 104, 150
 - changing starting DN 104
 - entering 89
 - in a network 24
 - length 8, 151
 - transparent dialing plan 24
- DISA (see Direct Inward System Access)
- DISA DN 144
- Disabled by sys 205, 210
- Disabled by user 205, 210
- Disabling 205, 210
- disabling
 - a device 206
 - a module 211
- disconnect supervision 120
 - loop start trunks 19
- disconnect timer 115
- display buttons 87
- display unreadable
 - troubleshooting 168
- distribution block
 - connecting the wiring 60
- DN (see directory numbers)
- DNIS Number 122
- DSX1 build out 117
- DTI (see Digital Trunk Interface)
- DTMF (see dual tone multifrequency)
- dual tone multifrequency
 - receivers 18, 42
- E**
- E&M gain level 123
- E&M Trunk Cartridge
 - cross connections 70
 - mixed service wiring 72
 - wiring chart 70
- E&M trunks 13
 - as prime line 16
 - incoming calls 16
 - outgoing calls 16
 - private network 15
 - remote access from private network 19
 - set filters 22
- electrical requirements 44
- electrical specifications 252
- electromagnetic compatibility 2
- emergency telephone
 - installing 77
 - testing 161
 - troubleshooting 170
 - Trunk Module 53
 - with E&M/DISA Trunk Cartridge 70
- emergency transfer
 - Direct Inward Dial Trunk Cartridge 74
- Enabling 205, 210
- enabling
 - a device 207
 - module or its cartridges 211
- entering Configuration 110
- environmental specifications 253
- equipment and supplies
 - installation checklist 41
- event messages
 - Maintenance 223
 - significant 223
 - system restarts 226

Evt 210-YYVZ 224
Evt 211-YYVZ 224
Evt 220-3546 224
Evt 221-3546 224
Evt 222-3546 224
Evt 255 224
Evt 263-302 224
Evt 264-302 224
Evt 265-302 224
Evt 268-07 224
Evt 269-3546 224
Evt 299 224
Evt 400 224
Evt 407 224
Evt 408 224
Evt 412-3546 225
Evt 413-3546 225
Evt 414-3546 225
Evt 415-3546 225
Evt 416-3546 225
Evt 417-3546 225
Evt 418 225
Evt 419 225
Evt 421 225
Evt 422-3546 225
Evt 423-3546 225
Evt 441 225
Evt 442 225
Evt 822 225
Evt 883 225
Expansion Cartridge
 installation planning 42
expansion equipment
 installation checklist 41
expansion modules 55
 connecting 54, 56
extended superframe 116

external code
 programming 148
external CSU
 connecting the DTI 67
external lines
 access code 148
 testing 162
external music source
 connecting 81
 impedance 81
 programming 82
external paging 82
 troubleshooting 179

F

Feature Cartridge
 installation 51
 pre-programming 112
feature codes
 troubleshooting 194
fiber cables
 installation 55
4 lines busy 210
framing format 116
full autohold 124

G

gain for E&M line 122

H

hearing-aid compatibility 2
Held Line Reminder
 Remind delay 139
Hold
 tones, music, or silence 142
Host delay 147
hung lines 172
Hybrid template 91
 button defaults 158

I

identify device connected to the system 203

Idle 205

idle line
search for 126

ILG (see Incoming Line Group)

Immediate signal type 121

impedance
setting for line 124

incoming line group 127
assignment 130

indicators
telephone button 87

individual DNs
programming 150

initializing the system
Startup programming 103

installation
auxiliary ringer 81
checklist 47
electrical requirements 44
emergency telephone 77
equipment and supplies
checklist 41
expansion equipment
checklist 41
external paging system 82
Feature Cartridge 51
fiber cables 55
internal wiring requirements
44
Key Service Unit and
expansion modules
checklist 43
location requirements 43
music 81

Norstar telephones 78
optional equipment checklist
43
planning checklist 41
spacing requirements 45

Installer password 103, 110
programming 149

intercom keys
programming 132

internal Channel Service Unit
117

internal wiring requirements 44

K

Key Service Unit 61
Background Music 143
cable connections 57
emergency telephone
installation 77
external loop start lines
wiring chart 66
installation checklist 43
numbering 61
telephone and auxiliary
equipment wiring chart 65
telephone wiring chart 64
troubleshooting 185
Trunk Cartridge slots 113
wiring arrangement 63

KSU (see Key Service Unit)

L

LEDs
Digital Trunk Interface 182

lightning protectors 44

- line
 - programming review 90
 - provisioning 234
 - search for idle 126
 - troubleshooting 171–177
 - line abilities defaults 100
 - Line Access 129
 - defaults 94
 - Line Access 110
 - Line assignment 129
 - line coding 118
 - Line data 125
 - line deprovisioning 234
 - line filters 21
 - line group 127
 - line loopback test 235
 - line numbers
 - entering 89
 - range 115
 - line pool 25, 125
 - access 131
 - access code 26, 148
 - compared to incoming line group 127
 - in a dialing plan 24
 - troubleshooting 195
 - Line Profile
 - reviewing programming 90
 - Line Redirection feature 39
 - line type 125
 - line/set filters 21
 - Link Time 146
 - location requirements
 - installation planning 43
 - log
 - Network 216
 - System Administration 214
 - System Test 212
 - Log Defaults 101
 - long telephone numbers 89
 - loop start trunk 13
 - as prime line 14
 - auto-answer 13
 - configuration requirements 14
 - incoming calls 13
 - manual-answer 13
 - remote access from public network 19
 - Loop Start Trunk Cartridge
 - wiring chart 69
 - Loopback Tests 199
 - loopback tests 235
 - initiated by the central office 238
 - initiated from Norstar 238
 - starting 239
 - stopping 240
 - loss package 124
 - loss/gain settings 124
-
- M**
-
- M7100 telephone
 - accessing external lines 14
 - button defaults 158
 - M7208 telephone
 - button defaults 158
 - M7310 telephone
 - button defaults 158
 - programming overlay 86
 - M7324 telephone
 - button defaults 160
 - central answering position 145
 - programming overlay 86

Maintenance

- alarm codes 218
- beginning a session 200
- bipolar violations 244
- carrier failure alarms 244
- Clock Source 228
- CSU Stats 241
- current alarm 213
- device version number 204
- disabling module or its
 - cartridges 211
- enabling the module or its
 - cartridges 211
- event messages 223
- identify device connected to
 - system 203
- Loopback Tests 235
- module inventory 209
- Module Status 208
- Network Log 216
- overview 199
- Port/DN Status 202
- Provisioning 234
- records 246
- short term alarms 244
- state of a cartridge 211
- state of a module 210
- state of device 205
- System Administration Log 214
- System Test Log 212
- System Version 201

Maintenance programming 106

Miscellaneous 143

- defaults 96

Miscellaneous 110

Mode

- destination codes 137
- programming 137
- Routing 137

module

- check number of Trunk
 - Cartridges 209
- checking the state 210
- enabling 211
- mounting 48
- numbering 208
- showing inventory 209
- troubleshooting 181–187
- verification 161

module numbering

- six-port Expansion Cartridge 62
- two-port Expansion Cartridge 61

Module Status 208

Module Status 199

module/cartridge compatibility 258

monitoring the T1 signal 184

mounting modules 48

mounting Norstar telephones on wall 79

moving telephones (see Automatic Telephone Relocation)

music

- installation 81
- license 4
- source 4

N**Names**

- defaults for set and line 97

network

- configuration samples 28
- private 33
- routing calls 135
- security 21
- transparent dialing plan 24
- troubleshooting 188–197
- user problems 188

Network Log 216

- check current alarm 216
- check items 217
- erase the log 217
- record 250

Network Log 199

networking

- options with Norstar 11
- private systems to Norstar system 12
- public network to Norstar system 12

No free lines 177

non-expanded system (KSU alone) numbering 61

Norstar

- as off-premise extension 12

Norstar system networking 11

Norstar telephones

- testing 162

Not available 205

numbers

- entering 89
- entering directory numbers 89
- entering line numbers 89
- viewing long telephone numbers 89

O

off-premise extension

- Norstar used as 12

On hold (see Hold)

Open Switch Interval

- disconnect timer 115

optional equipment

- installation checklist 43
- testing 162
- troubleshooting 178–179

P

paging

- installation 82

Park prefix 140

Park timeout delay 141

parked call

- retrieving 140

password

- calls answered with DISA 144
- changing Installer password 149
- Class of Service 16, 18
- defaults 101
- Installer 103, 110
- programming 149
- using DISA 23

payload loopback test 236

PBX template 91

- button defaults 158

personal programming data

- copying 155
- which can be copied 155
- which cannot be copied 155

port numbering 60

Port/DN Status 202

Port/DN Status 199

- ports
 - verification 161
 - power specifications 251
 - powering up the system 84
 - prime line 126, 132
 - prime telephone 128
 - Delayed Ring Transfer 140
 - private line 125
 - private network
 - remote access 20
 - tie lines 30
 - programming
 - alarm telephone 145
 - Auto DN 145
 - auxiliary ringer 81
 - central answering position assignment 145
 - Configuration 85, 110–152
 - copy set 155
 - define routes 136
 - Direct-Dial 144
 - directory numbers 150
 - exiting 89
 - Line Access 129
 - Maintenance 106
 - Miscellaneous 143
 - overlay 86, 110
 - overview 85
 - record 88
 - reviewing 90
 - Routing 134
 - Startup 103
 - system-wide characteristics 139
 - Trk/Line Data 111
 - viewing line 90
 - Provisioning 234
 - T1 lines 234
 - Provisioning 199
 - public line 125
- ## R
-
- radiated emissions 1
 - radio-frequency interference 1
 - Rec'd # 125
 - Rec'd # length 152
 - received number 125
 - received number length 152
 - receiver volume
 - programming 147
 - record
 - Network Log 250
 - System Administration Log 249
 - System Test Log 248
 - version number 247
 - registration
 - Norstar Key telephone system 3
 - remote access
 - dialing filters 21
 - Direct Inward Dial trunks 20
 - from public network 19
 - security 21
 - remote access packages
 - defaults 98
 - remote filters 22
 - remote system access 19
 - remote users
 - troubleshooting 188–197
 - repair facilities 5
 - replaced telephone status 170
 - replacing a telephone
 - of different types 169
 - of same type 169
 - ringer equivalence number 2

RJ2HX/CA2HA distribution
block

cross connections 70

route number 24

Routing 8, 24

DestCodes 137

DialOut 136

Mode 137

programming 134

defaults 95

tables 37, 135

Routing 110

S

security 21

Class of Service 21

dialing filters 21

Service Modes

defaults 101

new features 9

service tone cadences 251

set abilities

defaults 99

Set copy 153

compared to **Copy** 153

personal programming data
155

system data 154

set filters 21

E&M trunks 22

Set Profile

reviewing programming 90

signal type 121

significant event messages 223

six-port Expansion Cartridge 55

module numbering 208

SM (see Station Module)

spacing requirements 45

Specifications

Channel Service Unit 254

specifications

Digital Trunk Interface 253

electrical 252

environmental 253

power 251

service tone cadences 251

telephone loop 252

Square template 91

button defaults 158

Startup defaults 91

Startup programming 103

state of device

check 205

Station Module

installation planning 42

troubleshooting 186

wiring chart 68

superframe 116

supervisory signaling

Direct Inward Dial 74

Sys Admin Log 199

Sys Test Log 199

System Administration Log 214

System Data 150

defaults 96

System Data 110

system data

which can be copied 154

which cannot be copied 154

System Processor software 201

system restarts

event messages 226

System Speed Dial

defaults 97

System Test Log 212

event messages 223, 227

System Test Log record 248

- System Version 201
 - check version number 201
 - System Processor software 201
- System Version 199
- system-wide characteristics
 - Miscellaneous programming 143
- T**
- T1 lines
 - line coding 118
 - provisioning 108
- T1 signal
 - diagnostics 241
- T1 transmission performance 241
- T1 trunks 7
- target lines 13
 - and received number 125
 - incoming calls 18
- TC on KSU 113
- TC on TM 114
- TCs on 113
- telephone loop specifications 252
- telephone programming review 90
- telephones
 - troubleshooting 168–170
- template 91
 - changing default 103
 - default settings 91
- testing
 - Automatic Telephone Relocation 163
 - emergency telephone 161
 - external lines 162
 - modules 161
 - Norstar programming features 163
 - Norstar telephones 162
 - optional equipment 162
 - ports 161
 - system 161
 - wiring connections 161
- 3 sets busy 210
- TIA-547A
 - carrier failure standard 116
- tie lines 30
- Time and Date
 - defaults 97
- timer
 - answer 116
 - disconnect 115
- TM (see Trunk Module)
- TR64211
 - carrier failure standard 116
- Transfer Callback 140
- transparent dialing plan 24
- Trk/Line Data 110, 111

- troubleshooting 165
 - alarms 220
 - Analog Terminal Adapter 178
 - auxiliary ringer 178
 - Background Music 180
 - Digital Trunk Interface 182
 - emergency telephone 170
 - external paging 179
 - general procedure 166
 - Key Service Unit 185
 - line pools 195
 - lines 171–177
 - modules 181–187
 - network or remote users 188–197
 - optional equipment 178–179
 - replacing a telephone 169
 - Station Module 186
 - T1 signal 184
 - telephones 168–170
 - Trunk Cartridge 181
 - Trunk Module 186
 - types of problems 166
 - voltages on E&M leads 191
 - Trunk Cartridge
 - checking the state 211
 - Configuration 112
 - installation in Key Service Unit 53
 - installation planning 42
 - number attached to a module 209
 - troubleshooting 181
 - Trunk data
 - settings 119
 - defaults 92
 - Trunk mode 120
 - Trunk Module
 - DID Trunk Cartridges and RJ-21 wiring connections 75
 - troubleshooting 186
 - wiring arrangement 63
 - trunk type 119
 - Trunk/Line Data 111
 - trunks
 - Direct Inward Dialing 17
 - loop start 13
 - 2 ports busy 210
 - two-port Expansion Cartridge 54
 - module numbering 208
- ## U
-
- Unequipped 205, 210
 - unified dialing
 - directory number length 8
 - routing 8
 - starting directory number 8
 - unsupervised trunk mode 120
 - Updating state 210
 - upgrading your software 262
 - upgrading your system 257
 - Use route 138
- ## V
-
- version number
 - check device 204
 - Version Number record 247
 - VIEW->** 88
 - viewing long telephone numbers 89
 - viewing the programming for a telephone 90

W

- wall mounting Norstar telephones 79
- WinkStart signal type 121
- wiring
 - auxiliary ringer 81
 - Key Service Unit 57–58
 - Station Module 59
 - TrunkModule 59
- wiring arrangement
 - Key Service Unit 63
 - Trunk Module 63
- wiring chart
 - Auxiliary equipment 65
 - CI Trunk Cartridge 69
 - Digital Trunk Interface 67
 - E&M/DISA Trunk Cartridge 70, 71
 - Key Service Unit external loop start lines 66
 - Key Service Unit telephone 64, 65
 - Loop Start Trunk Cartridge 69
 - port numbering 60
 - Station Module 68
 - Trunk Module with DID
 - Trunk Cartridges and RJ-21 wiring connections 75
 - Trunk Module with Direct Inward Dial Trunk Cartridge 75
- wiring connections
 - verification 161

norstar

Norstar-PLUS (OX32)

Modular ICS Release 1-T1

System Coordinator Guide

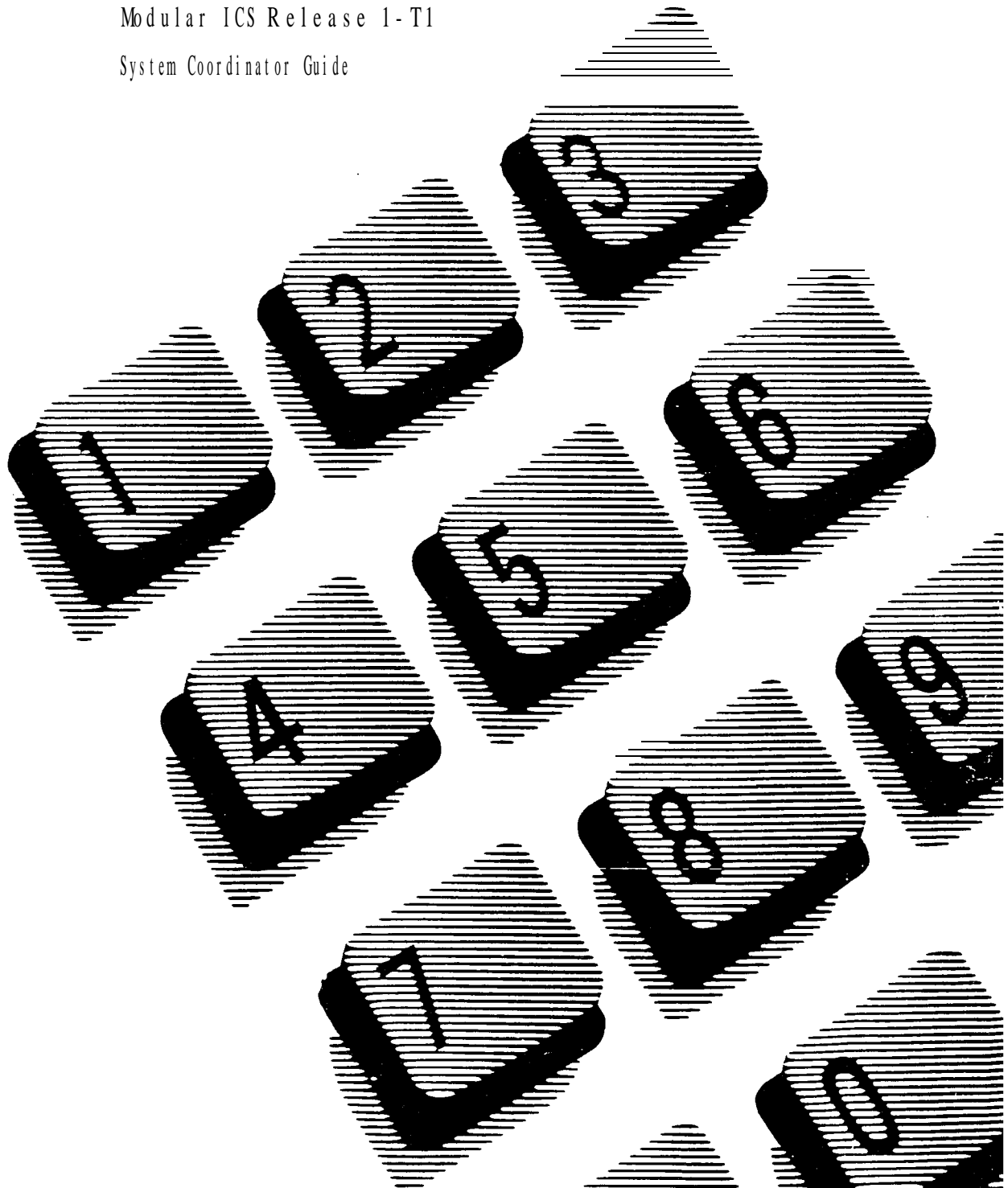

Contents

Welcome to Norstar 1

- Customizing Norstar 1
- Assisting your co-workers 2
- Your customer service representative 2

New Norstar features 3

- External direct-dial telephones 3
- Transparent dialing 3
- Expanded dialing filters 4
- Expanded Service Modes 4

Call Display services 5

- Call Display information 5
 - Call Log 7
 - Message Waiting 12
-

Programming 13

- Programming overview 13
- Before you start 14
- How to do programming 14
- Reviewing programming 16

Administration programming 17

- Entering Administration 18
- Exiting Administration 18
- Entering numbers 18
- Entering names 19

System Speed Dial 20

- Speed dial # 20
- Line selection 21
- Display digits 21
- System speed dial name 22
- Bypass restrictions 22

Names 23

- Telephone names 23
- Line names 24

Time and Date 25

- Setting the time 25
- Setting the date 26

- Direct-Dial 27
 - D-Dial1 27
- Capabilities 29
 - Dialing filters 30
 - Remote access packages 32
 - Set abilities 34
 - Line abilities 40
 - COS passwords 43
- Service Modes 45
 - Mode names 46
 - Mode times 47
 - Control sets 48
 - Finging service 49
 - Restriction service 50
 - Routing service 51
- Passwords 52
- Log Defaults 53
 - Reset all logs 53
- Call Services 54
 - Auto Call Info 54
 - Set services 55
 - VMsg centr tel#s 56
 - VMsg tel#s lines 57
- Reviewing programming 58
 - Viewing the programming for a telephone 58
 - Viewing the programming for a line 59
- Programming reminders 60
 - Norstar telephones 61
 - Prime telephones 62
 - Central answering positions 62
 - Page zones 63
 - Line pools 63
 - Miscellaneous programming 64
 - Call Pickup groups 64
 - Service Modes 65

Telephone basics 67

- Answer buttons 67
- Feature button 67
- Headset 67

- Hearing aid compatibility 68
- Hold button 68
- Incoming line group buttons 68
- Line buttons 69
- Memory buttons 69
- Release button 69
- Volume bar 69
- Wall mounting 70
- Answering the telephone 71
 - Call Display information 71
 - Call Park retrieval 72
 - Call Pickup 72
 - Call Queuing 72
 - Callback 72
 - Delayed Ring Transfer 72
 - Do Not Disturb 72
 - Handsfree 72
 - Voice Call Deny 73
 - What line indicators mean 73
 - Rings you may hear 73
- Making calls 77
 - Autodial 77
 - Direct-dial telephone 77
 - External line access code 78
 - Handsfree/Mute 78
 - Last Number Redial 79
 - Line pool access code 80
 - Saved Number Redial 80
 - Speed Dial 80
 - Voice Call 80
- Customizing your telephone 84
 - Automatic Handsfree 84
 - Button Inquiry 84
 - Dialing modes 84
 - Display contrast 85
 - Feature programming 85
 - Language choice 87
 - Moving line buttons 87
 - Pulse or tone dialing 87

- Special telephones 88
 - Alarm telephone 88
 - Central answering position 88
 - Control telephone 89
 - Direct-dial telephone 89
 - Emergency telephone 89
 - Extra-dial telephone 90
 - Hotline telephone 90
 - Prime telephone 91
- System features 92
 - Accidental Disconnect Protection 92
 - Automatic Telephone Relocation 92
 - Class of Service 92
 - Disconnect supervision 92
 - Hung lines 93
 - Internal numbers 93
 - Line assignment 94
 - Line pools 94
 - Incoming line groups 95
 - Overflow call routing 95
 - Prime line 95
 - Private lines 95
 - System Speed Dial 95
 - Target line 95
 - Set Lock 96
- Using Norstar remotely 97
 - Accessing Norstar remotely over the public network 97
 - Accessing Norstar over a private network 98
 - Using Norstar remotely 98
 - Controlling access to your Norstar system 99
 - Maintaining security 100

Telephone features 103

- One-line and two-line displays 103
- One button access 104
- Canceling a feature 105
- M7100 telephone 105
- What you can do with the features 105
- Autodial 108
 - Programming an external autodial button 108
 - Programming an internal autodial button 108

- Background Music 111
 - Listening to music 111
 - Canceling Background Music 111
- Button Inquiry 112
- Call Duration Timer 113
- Call Forward 114
 - Forwarding your calls 114
 - Canceling Call Forward 114
 - Call Forward on Busy 114
 - Call Forward (No Answer) 114
 - Overriding Call Forward 114
- Call Information 116
 - Displaying Call Information before or after answering 116
 - Displaying Call Information for a call on hold 116
- Call Log 118
 - Call Log options 118
 - Logging a call manually 119
 - Deleting old Log items 119
 - Viewing your Call Log 119
 - Viewing a Call Log item 120
 - Erasing Log items 120
 - Calling from Call Log 120
 - Call Log password 121
- Call Park 125
 - Parking a call 125
 - Retrieving a parked call 125
- Call Pickup 127
 - Directed Pickup 127
 - Group Pickup 127
- Call Queuing 129
- Camp-on 130
 - Camp a call 130
- Conference 132
 - Creating a conference 132
 - Disconnecting one party 132
 - Independently holding two calls 132
 - Putting a conference on hold 133
 - Splitting a conference 133
 - Removing yourself from a conference 133

- COS password 136
 - Changing your Class of Service 136
- Contrast adjustment 137
- Dialing modes 138
 - Choosing a dialing mode 138
- Do Not Disturb 140
 - Stop calls 140
 - Refusing to answer a call 140
 - Canceling Do Not Disturb 140
- Group Listening 141
 - Listening in a group 141
 - Canceling Group Listening 141
- Hold 142
 - Putting a call on hold 142
 - Retrieving a held call 142
 - Holding automatically 142
 - Listening on hold 142
 - Holding a call exclusively 142
- Host system signaling 144
 - Link 144
 - Pause 144
 - Programmed Release 144
 - Run/Stop 145
 - Wait for Dial Tone 145
- Language choice 146
 - English 146
 - French 146
 - Spanish 146
- Last Number Redial 147
 - Calling your last number 147
- Line pools 148
 - Using a line pool 148
- Line Redirection 150
 - Redirecting a line 150
 - Canceling Line Redirection 150
- Long Tones 155
 - Using Long Tones 155
- Messages 156
 - Sending a message 156

- Canceling a sent message 156
- Viewing your messages 156
- Replying to a message 157
- Removing items from your list 157
- Viewing your sent messages 157
- Moving line buttons 161
- Page 162
 - Making a page announcement 162
- Priority Call 164
 - Making a priority call 164
- Privacy 166
 - Creating a conference by releasing privacy 166
 - Making a private call 166
- Ring Again 167
 - Turning on Ring Again 167
 - Canceling Ring Again 167
- Ring type 168
 - Choosing a ring type 168
- Ring volume 169
- Saved Number Redial 170
 - Saving a number 170
 - Dialing a saved number 170
- Service Modes 171
 - Activating Ringing service 172
 - Canceling Ringing service 172
 - Activating the extra-dial telephone 172
 - Activating Restriction service 173
 - Canceling Restriction service 173
 - Activating Routing service 173
 - Canceling Routing service 174
 - Viewing the active Service Modes from a two-line display telephone 174
 - Viewing the active Service Modes from a one-line display telephone 174
- Speed Dial 177
 - Making a speed dial call 177
 - Programming Personal Speed Dial 177

- Time 180
- Transfer 181
 - Transferring a call 181
 - Canceling a transfer 181
- Trunk Answer 184
- Voice Call 185
 - Making a voice call 185
 - Muting voice call tones 185
 - Answering a voice call without touching your telephone 185
 - Preventing voice calls to your telephone 185
 - Canceling Voice Call Deny 185

User cards 187

- Telephone Feature Card 188
- Prime Telephone User Card 195
- M7100 Telephone User Card 199
- M7208 Telephone User Card 202
- M7310 Telephone User Card 205
- M7324 Telephone User Card 208

Glossary 211

Index 229

Welcome to Norstar

In addition to basic telephone service, your Norstar digital key system has many extra features that can greatly improve your office communications.

When a telephone system is first installed, it takes a bit of time to settle into using new equipment. Norstar minimizes this orientation by providing straightforward features and simple display-based instructions.

This guide can help you to learn the various tasks that you will perform as a system coordinator.

Customizing Norstar

The system coordinator plays an important role in customizing Norstar to suit the organization and in updating information as the office grows and changes.

Norstar can be customized at three levels:

Personal programming

Personal programming is done by individual telephone users who wish to personalize their Norstar telephones by programming features and telephone numbers onto specific memory buttons.

Administration programming

Administration programming is done by the system coordinator, when you want to change various system-wide settings and change some specific settings for each line or telephone.

Configuration programming

Configuration programming is usually done for you by the installer or customer service representative when Norstar is being installed. Specific system-wide parameters are set up in Configuration programming.



New Norstar features

External direct-dial telephones

Norstar now allows an external telephone to be a direct-dial telephone. You program the telephone numbers of each direct-dial telephone and determine which direct-dial telephone each Norstar user can reach using the direct-dial digit. See the sections on Direct-Dial and on Capabilities in the Programming chapter.

Transparent dialing

You can dial directly to other locations that are part of your private network, even if the call is long distance. The number you dial looks just like any other Norstar number for your system.

The secret is in the first digits of the dialed number. When your Norstar system receives these digits, it automatically selects an outgoing line from a line pool and adds any digits required to reach the location you're dialing. The number you dial is called a destination code. Your installer or customer service representative does the programming for transparent dialing.

As system coordinator, you are required only to activate the service modes which determine the routes to be used, depending on the time of day and day of the week. (See the next section and Service Modes in the Programming chapter for more information.)

Tips

Calls to and from these other locations are treated as external calls, even though they are part of the private network. This means that some of your Norstar features will not work on these calls, such as:

- Call Forward
- Send and Receive Message
- Ring Again
- Priority Call
- Voice Call
- Call Pickup

If you program an autodial button with a destination code, you must use the External Autodial feature code (*) and press to specify the line to use for the call.

Expanded dialing filters

You can now use dialing filters to create restrictions for feature codes that access features on other systems or on your central office switch. In certain cases, dialing one of these feature codes can allow a caller to bypass your system's dialing filters. Restricting the feature codes prevents these unauthorized calls.

Expanded Service Modes

Service Modes now let you control three different types of services by the time of day and day of the week. The three services are:

- Ringing
- Restriction
- Routing

Because of the increased number of services, three more modes have been added to the system, for a total of six service modes, in addition to normal service.

Ringing service

Up to now, you have been able to make additional phones ring by the time of day only. Now you can specify different additional ringing telephones by the time of day and the day of the week.

Restriction service

This new service gives you added flexibility in controlling unauthorized calls by changing the dialing filters after hours, on weekends, and on holidays. For information on creating and applying dialing filters see the Programming chapter.

Routing service

This new feature has been developed to let you use the cheapest available route out of several possible routes based on the call destination, time of day, and day of the week.

Your installer or customer service representative has determined charge rates by time of day and constructed a series of alternate routes for you. As system coordinator, all you need to do is turn Routing service on or off for each of the service modes.

Call Display services

Most public telephone companies offer Call Display services which provide information about an incoming call. The caller's name, telephone number and in some cases, a long distance indication, can be shown on a telephone with a display. Your Norstar system allows you to:

- view incoming call information as well as the name of the Norstar line that receives the call
- keep a log of incoming call information
- receive a display notification when you have received either a message from an internal Norstar user or a voice message from an external caller

You can access Call Display information only if you subscribe to the services offered by your public telephone company, and if you have the appropriate hardware installed. Contact your customer service representative for more information.

Call Display information

Call Display information may be shown on your telephone display when you answer an incoming call. In addition to the caller's name, telephone number and long distance indicator, if available, your Norstar system can display the name of the line that received the call.

If several users share a line, only one telephone can be designated to automatically receive Call Display information when a call is ringing on that line. If the call is transferred or camped to another telephone, the Call Display information is automatically available to that telephone.

If a line is not administered to automatically deliver Call Display information to a telephone, the user can view the information using the Call Information feature (see the Telephone features chapter) or by answering the call.

Depending on your requirements, Call Display information presents several convenient options:

- *When a caller is identified before the call is answered, you can answer using a personal greeting. You can also prepare yourself prior to answering the call by retrieving any relevant documents, or otherwise orienting yourself to the expected discussion.*
- *The long distance indicator alerts you that an incoming call is long distance and may therefore have higher priority.*
- *If you are unable to immediately attend to an incoming call, you can make a note to return the call later.*
- *You can shorten the interruption time of a call from a recognized person. For instance, you can quickly answer the call and let the party know that you are busy but will return their call soon.*
- *You can program a telephone to first display either the caller's name, number or line name. For example, an attendant might wish to see the calling number and area code first in order to transfer the call according to sales region. The salesperson's telephone could display the caller's name first so they can answer with a personal greeting.*

Call Display information allows you to answer calls on a priority basis. For example:

- *If several calls are ringing at your telephone at the same time, you can display information about the calls to decide which one is most important.*
- *If you are already on a call, information about a second call ringing at your telephone can help you to decide whether to answer the second call or remain connected to the first call.*
- *If you are in a meeting, the information associated with an incoming call can help you determine if the call is important enough to interrupt the meeting.*
- *If you have several calls on hold and wish to identify the callers, you can view the Call Display information associated with each of the calls to help you determine which one you will respond to first.*

Tips

In order for the designated telephone to automatically receive Call Display information, it must be programmed to ring for incoming calls on that line.

Before programming Call Display information you may wish to consider the following:

- Who would benefit the most from automatically receiving Call Display information?
- How are calls routed and what information is the most important to know before a call is answered? For instance, if certain lines are private to individuals, an attendant might wish to first view the line name to determine who the incoming call is for.

For further information on Call Information, see the Telephone features chapter. Programming actions are described in further detail in the Programming chapter.

Call Log

The Norstar Call Log feature uses incoming Call Display information to make a record of call details for follow-up. Call Log also records the time and date of the log entry, the number of repeated calls by the same caller, and which telephone answered the call if it was subsequently rerouted and handled by someone else in the Norstar system.

When the volume of incoming calls exceeds the ability of employees to handle all calls, or when staff are unavailable to answer calls, Call Log provides a convenient means of capturing information about missed calls.

When connected to a call that has Call Display information, the Logit feature of Call Log can be used to quickly record the caller's information for future use (see the Telephone features chapter for more information).

Tips

Call Log space is assigned to individual telephones in your system. Consider how much space each user needs.

Consider how the log will be used. Does the user want to return customer calls, track the numbers of calls unanswered, keep a record of most commonly called numbers, etc.?

Consider who is most interested in logging calls on a particular line. For instance, dentists working in a clinic may have an individual line assigned to them but prefer that the receptionist handle all of the calls logged on their line.

We strongly recommend that you limit the number of users logging calls for the same line, as this could be confusing. For example, if two users are logging calls for the same line, they do not know who the call was originally intended for, nor do they know when one of them returns a logged call. This could result in a call being returned twice.

For further information on Call Log, see the Telephone features chapter. Programming actions are described in further detail in the Programming chapter. See also the *Call Log Feature Card*. This card is available in a separately orderable Call Display Key Cap Kit. Contact your customer service representative for more information.

Sample configuration 1

Incoming calls are first answered at a central answering position (CAP) and then transferred to the required destination. The attendant wants to track all calls unanswered on the system, both during and after working hours. The users want to track their own unanswered calls and be able to return those calls from the log.

Call Log with a central answering position

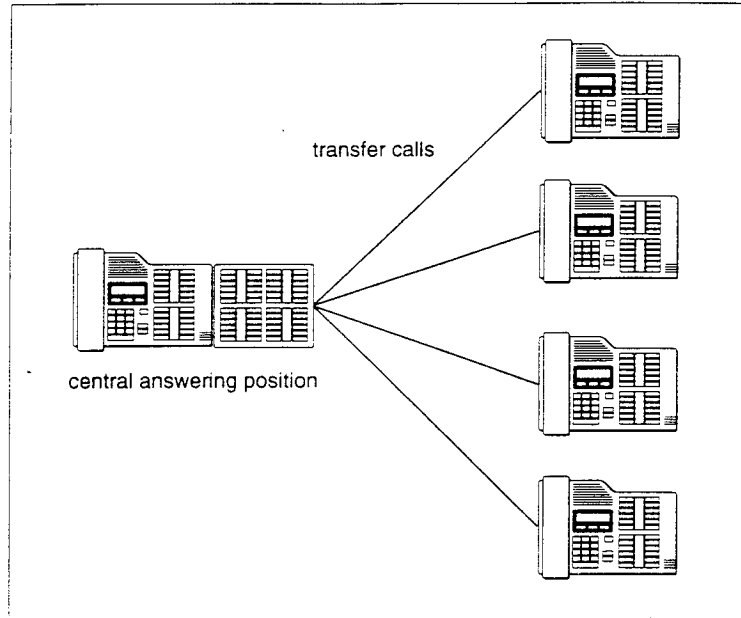

Configuration settings for CAP:

- Line assignment: All lines appear and ring at the CAP

Administration settings for CAP:

- Space/Log: Assign log space to each telephone
- Logging set: Y

Personal settings for CAP:

- Call Log options: * 8 4 - No one answered

Administration settings for telephone users:

- Logging set: N - Assign no lines.

Personal settings for telephone users:

- Call Log options: * 8 4 - Unanswered by me

Sample configuration 2

Each Norstar telephone has a unique line. The users have a variety of requirements for logging calls. Using * 8 4 the users can program logging capabilities specifically for their sets.

Call Log with dedicated lines

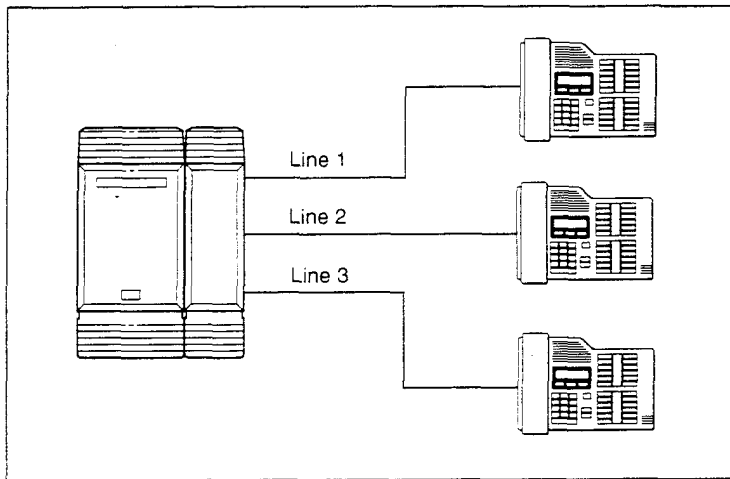

Configuration settings:

- Line assignment: Each telephone is assigned a line to appear and ring

Administration settings:

- Space/Log: Assign log space to each telephone
- Logging set: Y

Personal settings:

- Call Log options: * 8 4 - Each user chooses the appropriate option: No one answered, Unanswered by me, Log all calls, No autologging.

Sample configuration 3

The Norstar system has lines 1 and 2 appearing on all sets. The supervisor wants to log all calls for lines 1 and 2 at his/her set in order to analyze call traffic. Two users have been selected to return unanswered customer calls. To avoid confusion when logging and sharing lines, one user logs ~~no one answered~~ calls on line 1 and the second user logs ~~no one answered~~ calls on line 2. This clearly identifies who is responsible for returning calls for each line.

Call Logs with shared lines

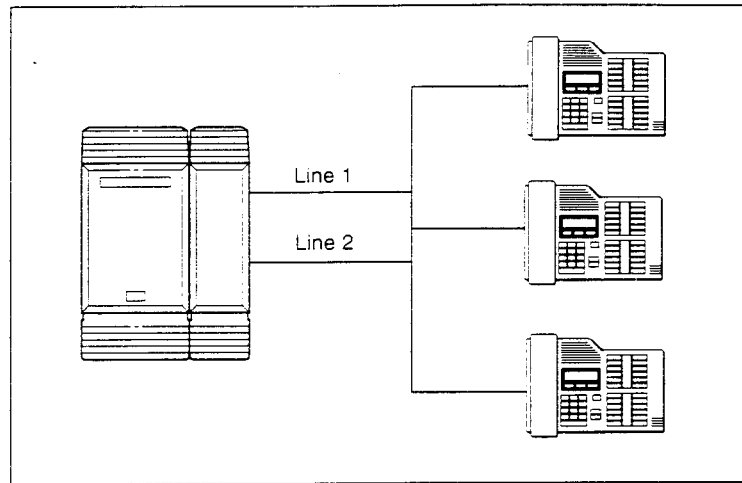

Configuration programming:

- Line assignment: Lines 001 and 002 are assigned to appear only at the supervisor's telephone. Line 001 is assigned to appear and ring at the first user's telephone. Line 002 is assigned to appear and ring at the second user's telephone.

Administration settings:

- Space/Log: Assign log space to each telephone
- Logging set: Assign the supervisor's telephone as a logging set for lines 001 and 002. Assign one user's telephone as a logging set for line 001 and the other user's telephone as a logging set for line 002.

Personal settings:

- Call log options: (Feature * 8 4) - Select **Log all calls** for the supervisor's telephone. Select **No one answered** for the user's telephones.)

Message Waiting

Norstar's Message feature allows you to send and receive internal message notification. If you have subscribed to voice messaging (provided by your public telephone company), you can:

- receive a visual indication that you have voice messages waiting
- call your voice message center to hear your messages
- clear the message waiting indication from your display

Tips

In order for a telephone to use this feature, it must have a line appearance and message waiting must be activated for that line by your public telephone company. You must also program visual message waiting indication for the telephone in Administration programming.

It is possible for two or more telephones to share a line appearance. You must determine if one, some or all of the users sharing a line will receive message waiting notification. If it is a sub-group, such as a sales team within a company, it may be appropriate to share the feature, provided that the users have an agreed upon procedure for retrieving and deleting messages.

For further information on Messages, see the Telephone features chapter. Programming actions are described in further detail in the Programming chapter.

Programming

Programming overview

When your system is installed, your installer or customer service representative programs it to work with your telephone lines, with your private network, if you have one, and with optional equipment. They also do some basic programming to make the system work properly in your office. Programming is recorded in the Norstar Programming Record.

You may wish to add to the programming your installer has done, to change how some features work, or to adapt the system to changes in your office. Administration programming lets you change settings that probably need to be updated regularly because of staff turnover or new business contacts. You can also assign some features to individual lines and telephones. This provides you with real flexibility in making your telephones work together.

There are three kinds of programming in a Norstar system: Configuration programming, Administration programming and personal programming.

Configuration programming is done for you by your installer or customer service representative. It deals mostly with how the system interacts with lines, telephones, and other equipment.

Administration programming deals with how features work for the system.

Personal programming is available to anyone through the Feature button on their Norstar telephone. It deals with how an individual telephone works.

In many cases, several kinds of programming are required to get a feature working. For instance, Norstar's Background Music feature allows you to listen to music from your telephone speaker while you work. To listen to background music you use a feature code on your telephone - personal programming. But unless there is a music source, such as a CD player, attached to your system, and unless the system is programmed to allow people to listen to background music, entering the feature code will produce a message telling you that the feature is not available.

In other cases, you will find that different aspects of a feature are controlled by different kinds of programming. For example, with Call Forward, you can forward your calls to another telephone any time you like by entering a feature code. You can also program the system so that it always forwards your calls if you are busy or if your telephone is not answered after a certain number of rings.

Before you start

Before you start, plan what programming you want to do. Record the changes in the Programming Record so you will have the information at hand. For example, if you are going to program system speed dial numbers, fill out the page in the Programming Record so you will have all the numbers and codes handy once you start programming.

How to do programming

You program the system from an M7310 or M7324 telephone. The telephone display guides you step-by-step through the process. While programming at a telephone, you cannot make or receive calls. Other users of the Norstar system may use their telephones, but cannot program any memory buttons. Only one Norstar telephone can access programming at a time.

While you do system programming, the buttons on your telephone take on special functions for navigating through the programming settings and for changing or selecting settings. These special functions are labeled on the programming overlay.

Norstar programming overlay

The programming overlay is a paper cutout that labels the telephone buttons used during programming. The programming overlay is provided at the end of this book.

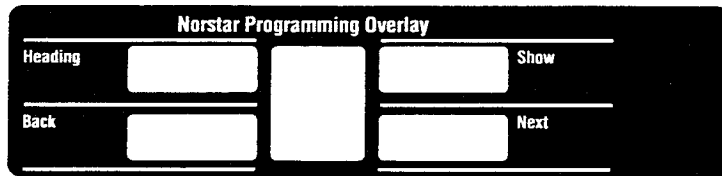

Place the programming overlay across the top four memory buttons of an M7310 or M7324 telephone.

M7310 telephone with a programming overlay

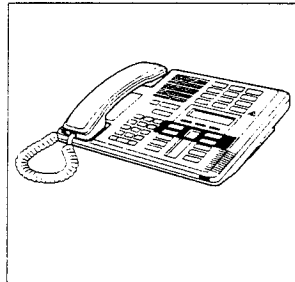

M7324 telephone with a programming overlay

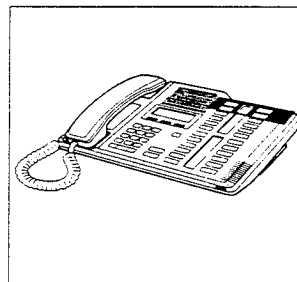

The ► indicators show which buttons can be used at each programming step. The buttons allow you to move through the headings and subheadings of Norstar programming.

moves up one level in the hierarchy of headings and subheadings

moves down in the hierarchy of headings and subheadings, or displays programming settings under a heading or subheading

moves to the next heading, subheading, or programmable setting

Norstar programming overlay

The programming overlay is a paper cutout that labels the telephone buttons used during programming. The programming overlay is provided at the end of this book.

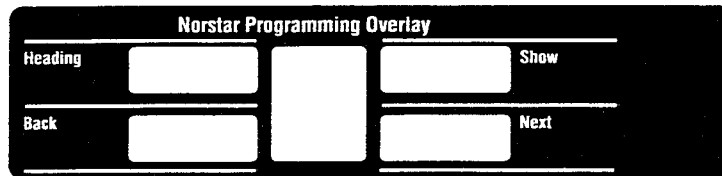

Place the programming overlay across the top four memory buttons of an M7310 or M7324 telephone.

M7310 telephone with a programming overlay

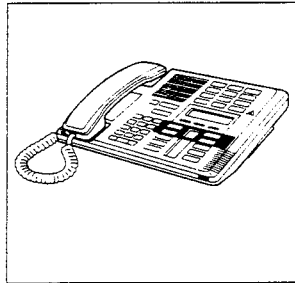

M7324 telephone with a programming overlay

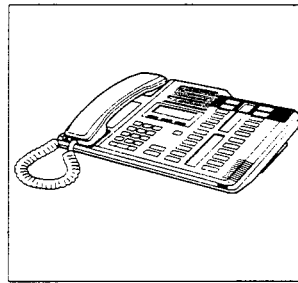

The ► indicators show which buttons can be used at each programming step. The buttons allow you to move through the headings and subheadings of Norstar programming.

- Heading moves up one level in the hierarchy of headings and subheadings
- Show moves down in the hierarchy of headings and subheadings, or displays programming settings under a heading or subheading
- Next moves to the next heading, subheading, or programmable setting

moves to the previous heading, subheading, or programmable setting

Using display buttons

Display buttons perform many functions during programming. Depending on where you are in programming, one, two, or three display buttons may be available at any one time.

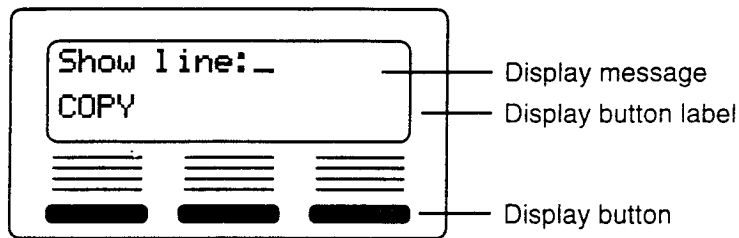

The most common display button labels are:

- CHANGE changes a programmable setting
- BKSP moves the cursor one space backward (backspace) and deletes a character, allowing you to re-enter a number or letter
- COPY copies line, telephone or capabilities programming.
- VIEW→ shows the last part of a displayed message that is longer than 16 characters
- ←VIEW shows the first part of a displayed message that is longer than 16 characters
- > moves the cursor one position to the right when programming a name
- <-- moves the cursor one position to the left when programming a name

Reviewing programming

You can use Set Profile and Line Profile to review the programming for a telephone or for a line. For more information, see Set Profile and Line Profile in the Telephone features chapter.

Administration programming

Administration programming lets you change settings for the entire Norstar system as well as settings for individual telephones and external lines.

Default programming settings are shown in bold type throughout this section. The option you see while programming may be different if that setting has been changed.

Headings and subheadings in Administration programming help you to keep track of where you are. Administration programming has nine headings:

- | | |
|--------------------------|--|
| 1. Sys speed dial | System speed dial assigns a two-digit code (01-70) for fast dialing of up to 70 telephone numbers from any Norstar telephone. |
| 2. Names | Names identifies external lines and Norstar telephones by name. |
| 3. Time and date | Time and date adjusts the time and date displayed on each Norstar telephone. |
| 4. Direct-Dial | Direct-Dial designates the telephones that can be reached by dialing a single digit. |
| 5. Capabilities | Capabilities defines dialing filters, remote access packages, line abilities and telephone abilities. It assigns restrictions and capabilities to class of service (COS) passwords, to telephones, to lines and to line/telephone combinations. |
| 6. Service Modes | Service Modes controls alternate call ringing, dialing restrictions, and call routing depending on the day of the week and the time of day. |
| 7. Passwords | Passwords changes the password that controls access to Administration programming. |

- | | |
|------------------|--|
| 8. Log Defaults | Log Defaults reallocates the Call Log space for all telephones in the system. |
| 9. Call Services | Call Services customizes the use of Call Display information. |

Entering Administration

1. Enter the Administration access code:
Feature * * A D M I N , which is also
Feature * * 2 3 6 4 6 . The display reads **Password:**
2. Enter the Administration password. The default password is ADMIN (23646). The display reads **1.Sys speed dial**. Three triangular indicators ► appear on the vertical display between the rows of buttons.
3. Place the programming overlay over the buttons pointed to by the indicators.

Exiting Administration

Norstar stores your changes automatically as soon as you alter any settings. You do not need to “save” your changes.

1. Press Rls .

Entering numbers

Always enter line numbers as three-digit numbers. Enter line numbers less than 100 with leading zeros (for example, line 002, and line 020).

Internal telephone numbers, also referred to as directory numbers (DNs), can be two to seven digits long on a non-expanded system, and three to seven digits long on an expanded system. The default DN length is two on a non-expanded system and three on an expanded system. The DN length can be changed by your customer service representative.

Entering names

You can enter letters as part of a name for various settings. The method of entering letters is always the same.

Begin with a setting that prompts you to enter a name. The display shows a cursor (**_**) to indicate where you can enter the next character. To enter a name:

1. Press the button on the dial pad with the printed letter or number that you want.

Each time you press the button, a new character is shown on the display. For example, the button for the number 3 has the letters **D**, **E**, and **F**, where:

- D** is shown after the first press
- E** is shown after the second press
- F** is shown after the third press
- 3** is shown after the fourth press
- D** is shown again after the fifth press.

(Letters are always shown in upper case.)

2. When the character that you want is displayed, press **-->** or **#** to move the cursor to the next character position.
3. Enter the next character.

To correct a character:

1. Press **<--** or ***** until the cursor is positioned beneath the character that you want to correct.
2. Enter the new character.

To delete a character:

1. Press **BKSP**.

System Speed Dial

The System Speed Dial programming section allows you to assign the external numbers your co-workers call most frequently to two-digit system speed dial codes. The numbers can then be dialed using the system speed dial codes.

1.Sys speed dial	
Speed dial #_	
	Max. 24 digits
Use prime line	
Display digits	Y
(If Display digits=N) Name	
	Max. 16 characters
Bypass restr'n	N

You can program 70 system speed dial codes ranging from 01 to 70.

Speed dial

Speed dial # lets you assign a telephone number to a two-digit system speed dial code. The number may contain 24 digits.

Begin with the display reading **1.Sys speed dial**.

1. Press **Show**. The display reads **Speed dial #**.
2. Enter the system speed dial code you want to program.
3. Press **Show**. The display shows the number currently assigned to the code, or **No number stored**.
4. Press **CHANGE**.
5. Enter the new telephone number including all digits such as an initial **9** or an area code that must be dialed to call the number manually.
6. Press **OK** to store the system speed dial number.

Tips

You can insert a host system signaling code into a system speed dial number. Pause and Run/Stop each use one character position. Link, Programmed Release and Wait for Dial Tone each use two positions. For more information on using host system signaling codes, see the Host system signaling section in Telephone features.

Use the Personal Speed Dial feature to program numbers used by only one or two people.

Line selection

You can specify the external line that is used when a system speed dial number is dialed. The options are the prime line, an external line, or a line in a line pool, or a line selected by the routing table. If you select the routing table, the number dialed is treated as a destination code and is routed according to the routing tables.

After you have programmed a system speed dial number:

1. Press **Next**. The display shows the line currently selected for that speed dial number.
2. Press **CHANGE** until the display shows the line that you want. If you choose **Use 1 line:** or **Pool code:**, you will have to enter a specific line number or pool code.

	<p style="text-align: center;">Telephone must have a line appearance to use speed dial</p> <p>If you assign a specific line to a system speed dial number, only telephones with an appearance of that line can use the speed dial number.</p>
---	--

Display digits

You can choose whether or not the telephone display shows the number dialed when you use a system speed dial number. If you choose not to display the number, you can program a name instead.

After you have programmed a line selection for a system speed dial number:

1. Press . The display reads **Display digits:**.
2. Press **CHANGE** to toggle the setting.

System speed dial name

If you choose not to display the number when a system speed dial number is dialed, you can program a name to display instead. The name can be up to 16 characters long.

After setting Display digits to N:

1. Press . The display reads **Name**.
2. Press . The display shows the currently assigned name.
3. Press **CHANGE**.
4. Enter the characters for the new name.

Tips

You can program System Speed Dial Name only if Display Digits is set to No.

For information on entering characters, see *Entering names in this chapter*.

Bypass restrictions

Bypass Restrictions allows you to choose whether or not a system speed dial number will be subject to the normally applicable dialing filter.

After programming the System Speed Dial Name:

1. Press . The display reads **ByPass restr'n:**.
2. Press **CHANGE** to toggle the setting.

Tips

Dialing filters are programmed and assigned in the Capabilities section of Administration programming.

Names

You can assign names to identify external lines, target lines and your co-workers' telephones. During a call, the name (if programmed) is shown on the telephone display instead of the external line number or internal telephone number of the caller.

2. Names	
Set names	
Show set: __	
221	Max. 7 characters
Line names	
Show line: __	
Line001	Max. 7 characters

Tips

Telephone names and line names can contain both letters and numbers, but cannot be longer than seven characters. You cannot use the # and * symbols.

You can give the same name to two or more telephones, or to a telephone and a line in your system. To avoid confusion, avoid such duplication. Use initials, abbreviations, or even nicknames to give each telephone a unique name.

Telephone names

Personalize your office communication by assigning names to the telephones in the Norstar system. A telephone's default name is its internal number, for example, 227.

Begin with the display showing **1.Sys speed dial.**

1. Press . The display reads **2. Names.**
2. Press until the display reads **Show set:.**
3. Enter the internal number of the telephone. The display shows the current name.
4. Press **CHANGE.**
5. Enter the characters of the name.

Tips

If Automatic Telephone Relocation is turned on, the name and internal number of a telephone are saved if the telephone is moved within your system.

For information on entering characters, see the Entering characters section in this chapter.

Line names

Line names allows you to assign a name to an external line. The default name is the line number, for example, **Line002**.

Begin with the display showing **1.Sys speed dial**.

1. Press . The display reads **2. Names**.
2. Press . The display reads **Set names**.
3. Press . The display reads **Line names**.
4. Press . The display reads **Show line:**.
5. Enter the line number. The display shows the current name.
6. Press **CHANGE**.
7. Enter the characters of the name.

Tips

When entering a name, press to go to the next line number. If you have not entered any characters yet, the default name is restored.

For more information on entering characters, see the Entering names section in this chapter.

Time and Date

Time and date programming allows you to set the time and date that is shown on the display when a telephone is not in use. As with any clock, this needs to be set every time your office has a power failure, and when you change between Daylight Savings and Standard Time.

3. Time and Date
Time
Date

Tips

All times and dates must be entered using numerals. For example, February would be entered as "2".

The time may be entered in either 12- or 24-hour format. If the display is in English, and the hour entered is less than thirteen, the display prompts you to specify **am** or **pm**.

The year is not shown on the telephone display, but make sure that it is set correctly. Norstar is programmed to allow for leap years.

English language displays always show the time in 12-hour format, while the alternate language displays always use the 24-hour format.

Setting the time

Begin with the display showing **1.Sys speed dial**.

1. Press until the display reads **3. Time and date**.
2. Press . The display reads **Time**.
3. Press **CHANGE**. The display reads **Hour:**. If you don't want to change the hour, skip to step 6.
4. Press **CHANGE**.
5. Enter the hour in two-digit format for the 12- or 24-hour clocks.
6. Press . The display reads **Minutes:**. If you don't want to change the minutes, skip to step 9.

7. Press **CHANGE**.
8. Enter the minutes.
9. Press . If you entered an hour less than 13, the display reads AM or PM.
10. Press **CHANGE** to toggle the setting.

Setting the date

Begin with the display showing **1.Sys speed dial**.

1. Press until the display reads **3. Time and date**.
2. Press . The display reads **Time**.
3. Press . The display reads **Date**.
4. Press **CHANGE**. The display reads **Year:**. If you don't want to change the year, skip to step 7.
5. Press **CHANGE**.
6. Enter the last two digits of the year.
7. Press . The display reads **Month:**. If you don't want to change the month, skip to step 10.
8. Press **CHANGE**.
9. Enter the month in two-digit format.
10. Press . The display reads **Day:**.
11. Press **CHANGE**.
12. Enter the day of the month in two-digit format.

Direct-Dial

Direct-Dial lets you dial designated telephones with a single digit. You can have up to five direct-dial telephones for your Norstar system. A direct-dial telephone can be inside your Norstar system or private network, or it can be outside the system in the public network. A direct-dial telephone is usually assigned to a receptionist for an entire office or for a particular department.

4. Direct-Dial	
D-Dial1	Intrnl
(if D-Dial1=Intrnl) Intrnl #	221
(if D-Dial1=Extrnl) Extrnl #	None
(if D-Dial1=Extrnl) Use prime line	
D-Dial2	None
D-Dial3	None
D-Dial4	None
D-Dial5	None

D-Dial1

For each of the five direct-dial telephones, indicate whether it is an internal or external number.

Use and **CHANGE** to toggle the setting: **Intrnl**, **Extrnl**, or **None**.

Number

Enter the internal or external numbers that the system will automatically dial when someone enters the direct-dial digit.

Use , **CHANGE**, and the dial pad to enter each of the five telephone numbers. The default number for the first direct-dial telephone is **221**.

Line selection

If you assign an external number as a direct-dial telephone, you must indicate which line to use for the call.

Use , **CHANGE**, and the dial pad to select the line for the external number.

Tips

There is just one direct-dial digit for the entire system. However, each person in your system does not reach the same direct-dial telephone when they dial this digit. See the Set abilities section of the Capabilities chapter to assign which telephone each person can reach through Direct Dial.

The digit you dial in order to get a direct-dial telephone to ring is programmed by your customer service representative.

The Norstar system cannot verify that the number you assign as an external direct-dial telephone is valid. Check the number before assigning it as a direct-dial telephone, and call the direct-dial telephone after you've assigned it in order to test it.

You cannot forward calls to any direct-dial telephone that is outside your Norstar system. See Call Forward in the Telephone features chapter.

Capabilities

Capabilities programming assigns restrictions, exceptions, and remote access capabilities to Class of Service (COS) passwords, telephones, and lines.

5. Capabilities		Mode 4 ftr	None	Show line: _	
Dialing filters		Mode 5 ftr	None	Line filters	
Show filter: _		Mode 6 ftr	None	Normal filter	03
Restr'n 01		Set lock	None	Mode 1 filter	21
Excpt'n 001		Full handsfree	N	Mode 2 filter	22
Excpt'n 002		(if Full handsfree=Y)		Mode 3 filter	23
Restr'n 02		Auto handsfree	N	Mode 4 filter	00
Rem access pkgs		HF answerback	Y	Mode 5 filter	00
Show package: _		Pickup group	NO	Mode 6 filter	00
Line pool access		Paging	Y	Remote filters	
Pool A to O		Page zone	1	Normal filter	04
Remote page		Aux. ringer	N	Mode 1 filter	31
Remote page		Direct-dial	Set1	Mode 2 filter	32
Set abilities		Forward on busy		Mode 3 filter	33
Show set: _		Forward to	None	Mode 4 filter	00
Set filters		Forward no answr		Mode 5 filter	00
Normal filter		Forward to	None	Mode 6 filter	00
Mode 1 filter		(if forwarded on no answer)		Remote pkg	00
Mode 2 filter		Forward delay	3	COS passwords	
Mode 3 filter		Allow redirect	N	Show password: _	
Mode 4 filter		Redirect ring	Y	Pswd00	None
Mode 5 filter		Hotline	None	User ftr	Deflt
Mode 6 filter		(if Hotline=Intml)		Line ftr	Deflt
Line/set filters		Intml#	None	Remote pkg	Deflt
Show line: _		(if Hotline=Extml)		Pswd01	None
Normal ftr		Extml#	None		
Mode 1 ftr		Use prime line			
Mode 2 ftr		Priority call	N		
Mode 3 ftr		Line abilities			

Dialing filters

A dialing filter is a set or group of restrictions and exceptions that specify the external numbers or feature codes that cannot be dialed from a telephone or on a line. Rather than define individual restrictions and exceptions and apply them repeatedly to telephones and to lines, dialing filters lets you assign them in one step as a single set.

In addition to creating restrictions for telephone numbers, you can create restrictions for feature codes that access features on other systems or on your central office switch. Some of these features provide the caller with dial tone after they have entered the feature code. This can provide users with an opportunity to bypass dialing filters and dial a call that would normally be restricted. Creating restrictions for the feature codes themselves prevents these unauthorized calls.

You create a dialing filter by defining a set of restrictions and its associated exceptions. You can then assign the filter to a telephone (set filter in Set abilities), to a line (line filter in Line abilities), to a particular line on a telephone (line/set filter in Set abilities), and to remote caller (Remote filter in Line abilities).

Use ADD, the dial pad, and OK to program the restrictions for each dialing filter.

Press ANY to enter a • wild card character that represents any digit in a sequence of numbers.

After programming a restriction, press to program the exceptions to that restriction. Use ADD, the dial pad, and OK to program the exceptions for each restriction.

Default filters

Filter 00 permits unrestricted dialing, and cannot be changed.

Filter 01 is preprogrammed with five restrictions and some associated exceptions.

Dialing filter defaults

Filter	Square, Hybrid, PBX, DID		Centrex	
	Restr'ns	Excpt'ns	Restr'ns	Excpt'ns
00	Unrestricted dialing			
01	0		90	
	1	1800 1555 1•1•555 1•0•555	91	91800 91555 91•1•555 91•0•555
	911	911	9911	9911
	411		9411	
	976		9976	
02 - 99	None			

Filters 02, 03, and 04, although not preset with restrictions and exceptions, are the default filter settings used later in programming.

Filter	Where the filter is programmed as a default setting in Capabilities programming
02	Set abilities Set filter:
03	Line abilities line filter:
04	Line abilities Remote filter:

Tips

Filter 00 cannot be changed.

Norstar can have up to 100 dialing filters (00 to 99).

Each programmable filter can have up to 48 restrictions. There is no limit on the number of exceptions that can be allocated to a restriction.

There is a maximum of 400 restrictions and exceptions allocated to the 100 programmable filters.

The maximum length of a restriction is 15 digits. The maximum length of an exception is 16 digits.

The • is a “wild card” that stands for any digit.

You can use * and # in a sequence of numbers in either a restriction or an exception. These characters are often used as part of feature codes for other systems or for features provided by your central office.

When restricting the dialing of a central office feature code, don't forget to create separate restrictions for the codes used for DTMF and pulse lines. For example, *67 and 1167.

Do not string together a central office feature code and a dialing sequence that you want to restrict. Create a separate restriction for each.

You can use COPY and the dial pad to copy restrictions and overrides from one dialing filter to another.

Any restriction or exception can be used in any number of filters. Each time it is used, it counts as one entry. For example, if restriction 411 exists in filters 01, 02 and 03, it uses up three entries of the 400 entries available.

Removing a restriction also removes the exceptions associated with it, and changes the identifying number of the restriction. For example, removal of restriction 01 renumbers restrictions 01 to 08 as 01 to 07.

Removing a restriction from a dialing filter has no effect on the contents of other filters even if the restriction was copied to them.

You cannot delete a filter. Removing the restrictions programmed on a filter makes it an unrestricted filter but the filter itself is not removed.

Remote access packages

Remote access packages allow you to control the remote use of Norstar line pools and the Page feature.

You create a remote access package by defining which of your system's line pools it will be able to access and whether it can use your page feature. You then assign the package to individual lines (Remote pkg in Line abilities), and to a particular class of service password (Remote pkg in COS passwords).

Use and the dial pad to select the remote access package you want to program. Then, press **CHANGE** to select the line pool access setting: **N** (No) or **Y** (Yes). After programming line pool access, press **CHANGE** to select the Remote page setting: **N** (No) or **Y** (Yes).

Remote access packages defaults

Parameter	Square	Centrex	Hybrid	PBX	DID
Package 00	Prohibits remote access to line pools and Page. Cannot be changed.				
Package 01					
Line pool access	Y for Pool A N for Pools B to O				
Remote Page	No				
Packages 02 - 15					
Line pool access	N for Pools A to O				
Remote Page	No				

Tips

You can use **COPY** and the dial pad to copy settings from one remote package to another.

The line pool access display shows an alphabetic line pool identifier, followed by a numeric line pool access code in brackets, for example, **Pool A <9>:N**. If no access code has been identified, there is nothing between the brackets, for example **Pool A < >:N**. The line pool access code can be programmed by your customer service representative.

Remote package 00 is the default setting for the Remote package setting. It permits **no** access to line pools or to remote paging. Unlike packages 01 to 15, package 00 cannot be changed.

You can define up to 16 remote access packages (00 to 15).

For remote users who call into the Norstar system to use Norstar lines for calling out, the Remote filters and Line filters still apply.

You can use **COPY** and the dial pad to copy line abilities programming from one line to another.

Set abilities

Set (Telephone) abilities programming applies dialing filters and permissions to telephones. Telephone abilities includes the following headings.

Tips

You can use **COPY** and the dial pad to copy set abilities programming from one telephone to another.

Set filter

Set filter lets you assign a dialing filter to a telephone to restrict the numbers that can be dialed from that telephone. You can assign a different dialing filter for normal service and for each of six service modes. See the Service Modes chapter for more information about service modes.

Use , **CHANGE** and the dial pad to enter the number of the dialing filter to be assigned as the set filter for each mode. The default set filters are as follows:

Default set filters

Mode	Dialing filter
Normal	02
Mode 1 (Night)	11
Mode 2 (Evening)	12
Mode 3 (Lunch)	13
Mode 4	00
Mode 5	00
Mode 6	00

Tips

Set filters do not apply to calls dialed out on E&M trunks. Someone could dial out to a destination on the private network that is restricted on the public network. To restrict calling on E&M lines, apply a dialing filter to the line rather than to the telephone.

Line/set filter

Line/set filter lets you assign a dialing filter to a specific line that appears at a specific telephone. This type of filter replaces any line or set filters which might otherwise apply. It restricts the numbers you can dial on a line, but only from this particular telephone. The same line on another telephone can have different restrictions.

As with set filters, you can apply a different line/set filter for normal mode and each of six service modes.

Use , **CHANGE** and the dial pad to enter the number of the dialing filter to be assigned as the line/set filter for each mode. The same default filters are used as for set filters.

Tips

A maximum of 255 line/set filters may be applied to lines at telephones.

If a line/set filter is assigned to a line at a particular telephone, it overrides any line filters or telephone filters which might otherwise apply.

If no line/set filters have been defined, dialed digits are filtered through (and may be rejected by either of) the set filter (if defined) and the line filter (if defined).

Set lock

Set lock limits the features that may be used or programmed at a telephone. Use CHANGE to select one of the three options: **None**, **Partial** and **Full**.

None allows you to access any feature on your telephone.

Partial prevents:

- programming autodial buttons
- programming personal speed dial numbers
- programming feature buttons
- moving line buttons
- changing the display language
- changing dialing modes (Automatic Dial, Pre-Dial, and Standard Dial)
- using Voice Call Deny
- using Administration programming
- saving a number with Saved Number Redial

Full, in addition to the restrictions outlined for Partial lock, prevents:

- changing Background Music
- changing Privacy
- changing Do Not Disturb
- using Ring Again
- using Call Forward all calls
- using Send Message
- using Trunk Answer
- activating Service Modes

Full handsfree

Full handsfree allows you to make or receive calls without picking up the receiver. It also allows you to use a headset with a Norstar telephone. Use CHANGE to select the setting: **N** (No) or **Y** (Yes).

Tips

A Handsfree/Mute button is automatically assigned to a telephone that is programmed with Full Handsfree. The Handsfree/Mute button is always located in the lower right-hand corner of the telephone.

Full Handsfree is always disabled for an M7100 telephone.

Auto handsfree

Automatic handsfree activates the handsfree microphone and speaker when you make or receive calls by pressing a line button. Use CHANGE to select the setting: **N** (No) or **Y** (Yes).

Tips

You can program automatic handsfree only if the telephone has Full Handsfree set to **Y** (Yes).

HF answerback

Handsfree answerback allows you to answer a voice call without lifting the receiver. Press CHANGE to select the setting: **Y** (Yes) or **N** (No).

Tips

Handsfree answerback is always disabled for an M7100 telephone.

Pickup group

Each telephone can be assigned to one of up to nine Call Pickup groups. Members of a Call Pickup group can answer any calls ringing at a telephone in the group. Press CHANGE to select the setting: **NO**, 1, 2, 3, 4, 5, 6, 7, 8, or 9.

Tips

You cannot pick up a call that is on a private line, or a call that is ringing only an auxiliary ringer.

Paging

Paging lets you determine whether a telephone has access to the Page feature. Press CHANGE to select the setting: **Y** (Yes) or **N** (No).

Page zone

Each telephone can be assigned to one of six zones for receiving pages. Press CHANGE to select the setting: **1**, **2**, **3**, **4**, **5**, **6**, or **NO**.

Tips

You can program Page zone only if the telephone has Paging set to Y (Yes).

A zone is any set of Norstar telephones that you want to group together, regardless of their location.

Auxiliary ringer

Auxiliary ringer lets you set whether an installed auxiliary ringer rings when a telephone receives a call. An auxiliary ringer is important in noisy environments where a Norstar telephone might otherwise not be heard. Press CHANGE to select the setting: **N** (No) or **Y** (Yes).

Direct-dial telephones

Assign which direct-dial telephone is called when you dial the direct-dial digit from this telephone. Press CHANGE to select the setting: **Set1**, **Set2**, **Set3**, **Set4**, **Set5**, and **None**.

Tips

Each telephone can call only one direct-dial telephone, although up to five direct-dial telephones can be designated in the Direct-Dial section of Administration programming. Any number of telephones can be assigned to call a particular Direct-Dial telephone.

The digit you dial in order to get the Direct-Dial telephone to ring can be programmed by your customer service representative.

Forward on busy

Forward on busy redirects your calls to another telephone on your Norstar system when you are busy on a call, or when you have Do Not Disturb activated at your telephone.

Use Show , CHANGE, and the dial pad to program the internal number of the telephone that your calls are to be directed to.

Tips

If you are busy on a target line call, another call to that target line is redirected to the prime telephone for that target line.

Line Redirection takes precedence over Call Forward busy.

Forward no answer

Forward No Answer lets you redirect your unanswered calls to another telephone on your Norstar system.

Use , **CHANGE**, and the dial pad to program the internal number of the telephone that your calls are to be directed to.

Tips

Line Redirection takes precedence over Call Forward no answer.

Forward delay

If you assign another telephone to receive your unanswered calls, you can also assign the number of times that the incoming call rings at your telephone before the call is forwarded. Press **CHANGE** to select the setting: 2, **3**, 4, 6, or 10 rings.

Tips

To estimate the delay time in seconds, multiply the number of rings by six.

Allow redirect

Allow redirect determines whether you can use the Line Redirection feature. Press **CHANGE** to select the setting: Y (Yes) or N (No).

See Line Redirection in the Telephone features chapter for more information on redirecting lines.

Redirect ring

You can program a telephone to ring briefly (a 200 millisecond burst) when a call is redirected on one of its lines. Press **CHANGE** to select the setting: Y (Yes) or N (No).

See Line Redirection in the Telephone features chapter for more information on redirecting lines.

Tips

If a telephone has redirect ring enabled, it rings briefly for redirected calls on one of its lines even if another telephone set up the line redirection.

Hotline

You can set up a telephone as a hotline, so that it automatically calls a pre-assigned number when you lift the receiver or press

. Hotline has three options: **None**, internal, and external.

Internal assigns an internal number.

External assigns an external number. If you select an external number, you can also select the line on which the call is made: the prime line, an external line, a line in a line pool, or a line selected by the routing table. If you select a line pool, you will have to specify the line pool access code. If you select the routing table, the number dialed is treated as a destination code and is routed according to the routing tables.

Use **CHANGE** to select Hotline setting.

Use , **CHANGE**, and the dial pad to program the number that is automatically dialed.

Tips

Label the telephone to inform anyone using it that Hotline is active.

A telephone's prime line, line pool access codes, and access to a line pool can be programmed by your customer service representative.

Priority call

Priority call determines whether you can use the Priority Call feature to make a voice call to another Norstar telephone even when it is busy or when it has Do Not Disturb activated. Press **CHANGE** to select the setting: **N** (No) or **Y** (Yes).

Tips

Allow this feature only when a telephone has a legitimate need for it.

Line abilities

Line abilities programming applies dialing filters, remote access dialing filters and remote access packages to lines.

Tips

You can use **COPY** and the dial pad to copy line abilities programming from one line to another.

Line filters

Specify the dialing filter to be applied to this line to restrict the numbers that can be dialed on it. A dialing filter is a set or group of restrictions and exceptions. You can assign a different dialing filter for normal service and for each of six service modes. See the Service Modes chapter for more information about service modes.

Use , **CHANGE** and the dial pad to enter the number of the dialing filter to be assigned as the line filter for each mode. The default line filters are as follows:

Default line filters

Mode	Dialing filter
Normal	03
Mode 1 (Night)	21
Mode 2 (Evening)	22
Mode 3 (Lunch)	23
Mode 4	00
Mode 5	00
Mode 6	00

Tips

If a remote user tries to use this line to place an external call, the line filter still applies.

Remote filters

Specify the dialing filter to be applied to remote callers calling in to the Norstar system on this line. A dialing filter is a set or group of restrictions and overrides.

As with line filters, you can apply a different remote filter for normal mode and for each of six service modes.

Use **CHANGE** and the dial pad to program the remote filter for each mode. The default remote filters are as follows:

Default remote filters

Mode	Dialing filter
Normal	04
Mode 1 (Night)	31
Mode 2 (Evening)	32
Mode 3 (Lunch)	33
Mode 4	00
Mode 5	00
Mode 6	00

Tips

The remote filter restricts the numbers that can be dialed on an incoming auto-answer line. If a remote user then selects a line to place an external call, the line filter applied to that line still applies.

Remote package

Specify the remote package to be applied to remote callers trying to use line pools or the Page feature on your system.

Use **CHANGE** and the dial pad to program the remote package.

Tips

Package 00 is the default remote package, which gives no remote access to line pools or to Page.

You can define Class of Service passwords that allow selected remote users to access your system line pools and page feature.

COS passwords

Class of Service passwords permit controlled access to a system's resources by internal and remote users. When you enter a Class of Service password at a telephone, the dialing filters associated with your Class of Service password apply, rather than the normal dialing filters. Similarly, when a remote user enters a Class of Service password on an incoming auto-answer line, the dialing filters and remote package associated with their Class of Service password apply, rather than the normal dialing filters and remote package.

COS passwords lets you define individual passwords and determine the dialing filters, and remote package associated with each.

Tips

Class of Service passwords for a system should be determined randomly, and should be changed on a regular basis.

Users should memorize their COS passwords instead of writing them down.

Employees' COS passwords should be deleted when they leave the company.

Typically, each user has a separate password. Several users can share a password or one user can have several passwords.

A system can have a maximum of 100 six-digit COS passwords (00 to 99).

You can use COPY and the dial pad to copy the dialling filters and remote package from one COS password to another.

COS passwords must be unique.

Pswd

Pswd defines the six-digit Class of Service password.

Use , CHANGE, and the dial pad to program the six-digit password. Use BKSP to edit numbers you have entered.

User fltr

User fltr lets you assign a dialing filter to a Class of Service password. The user filter associated with the Class of Service password replaces any normally applicable set filter, line/set filter, and remote filter.

Use , **CHANGE**, and the dial pad to program the two-digit user filter. The default setting (**Def1 t**), means that any normally applicable filters (set filter, line/set filter, or remote filter) still apply.

Line fltr

Line fltr lets you assign a specific line filter to a Class of Service password. The line filter associated with the Class of Service password replaces any normally applicable line filter.

Use **CHANGE** and the dial pad to program the two-digit line filter. The default setting (**Def1 t**), means that any normally applicable line filter still applies.

Remote pkg

Remote pkg lets you assign a specific remote access package to a Class of Service password. The remote access package associated with the Class of Service password replaces any normally applicable remote access package.

Use **CHANGE** and the dial pad to program the two-digit remote package. The default setting (**Def1 t**), means that any normally applicable remote access package still applies.

Service Modes

6. Service Modes		Day:Wed	Mode 4	Off	
Mode names		Day:Thu	Mode 5	Off	
Mode 1	Night	Day:Fri	Mode 6	Off	
Mode 2	Evening	Day:Sat	Restr'n service		
Mode 3	Lunch	Day:Sun	Mode 1	Off	
Mode 4	Mode 4	Control sets		Mode 2	Off
Mode 5	Mode 5	Show line: _	Mode 3	Off	
Mode 6	Mode 6	Line001	221	Mode 4	Off
Mode times		Show set: _	Mode 5	Off	
Day: Mon		221	221	Mode 6	Off
Mode 1: Night	Start time	23:00	Ringing service		
	Stop time	7:00	Mode 1	Off	
Mode 2: Evening			Trunk answer	Y	
Mode 3: Lunch			Extra-dial	221	
Mode 4: Mode 4			Show line: _		
Mode 5: Mode 5			Ringing sets	221	
Mode 6: Mode 6			Aux. ringer	Y	
Day:Tue		Mode 2	Off	Routing service	
		Mode 3	Off	Mode 1	Off
				Overflow	N
				Mode 2	Off
				Mode 3	Off
				Mode 4	Off
				Mode 5	Off
				Mode 6	Off

Using Service Modes, you can control three types of service by the time of day and day of week:

- alternate call ringing for certain times and days
- alternate dialing restrictions for certain times and days
- alternate call routing for certain times and days

You can program up to six different Service Modes, each with different services. For example, you may want to combine alternate call ringing with alternate dialing restrictions for lunchtime, evenings, and weekends (Service Modes 1, 2, and 3). Then you may want three separate modes to control alternate call routing.

Tips

Once you have programmed the different Service Modes, you can turn each of the services on separately. For example, Night mode might control both Ringing service and Restriction service. But you can turn on just the Ringing service part of Night mode if you wish.

You can activate the services from the designated control telephone for each Norstar telephone and line in your system. You can have one control telephone for the whole system, or different control telephones for different Norstar telephones and lines. See Service Modes in the Programming chapter and in the Telephone features chapter for instructions on programming and activating the different services.

If you want to have several services active at the same time, simply program them on for the same mode.

Mode names

The Service Mode name is shown on the display of the control telephone when the Service Mode is turned on. It identifies the active Service Mode.

Use Show , **CHANGE**, Next , and the dial pad to program the Service Mode name. For information on entering names, see the Entering names section in this chapter.

Tips

The default names of the six possible Service Modes are only suggestions, and may be changed to any other name.

A Service Mode name can be one to seven characters long.

It is recommended that you reserve certain Service Modes (modes 4, 5, and 6) exclusively for alternate call routing.

Mode times

Mode start and stop times correspond to typical hours which may be required for a Service Mode.

Use , **CHANGE**, , and the dial pad to program the start and stop times for each Service Mode, on each day.

Default Service Mode times

Service Mode	Start time	Stop time
Service Mode 1: Night	23:00	07:00
Service Mode 2: Evening	17:00	23:00
Service Mode 3: Lunch	12:00	13:00
Service Mode 4: Mode4	00:00	00:00
Service Mode 5: Mode5	00:00	00:00
Service Mode 6: Mode6	00:00	00:00

Tips

It is only necessary to program start and stop times for Service Modes that are activated automatically. See the section in this chapter on Ringing service for information on activating Service Modes.

The time may be entered in either 12 or 24-hour format. If the display is in English, and the hour entered is less than thirteen, the display prompts you to specify **AM** or **PM**.

If you assign identical start and stop times for a mode, for example, 04:00 start and 04:00 stop, the mode is in effect all day. The only exception to this is a start and stop time of 00:00; in this case the mode is off for the day.

You may assign overlapping times. For example, if Service Mode 1 is assigned from 9:00 am to 4:00 pm and Service Mode 2 is assigned from 1:00 pm to 5:00 pm, then the start time of the second Service Mode is treated as a stop time for the first Service Mode. This is also true if two Service Modes have the same start time but different stop times; the stop time of the shorter mode is treated as the start time of the longer mode.

If one Service Mode starts and stops within the times of another Service Mode, the first service temporarily ends when the second service starts. The first service then resumes when the second service has ended.

Some Service Modes start and stop at the same times each day: use COPY to copy the start and stop times from one day to the next.

	<p style="text-align: center;">Start and stop times don't span days</p> <p>When you program a Service Mode to start in the evening and stop in the morning, it does not carry over into the next day. For example, if you program Night service for Friday (10 pm to 6 am), the system turns on Night service from midnight to 6 am on Friday, and then again from 10 pm to midnight on Friday.</p>
---	--

Control sets

A control telephone turns Service Modes on and off for the lines and/or telephones assigned to it. You can assign several control telephones for your system. A control telephone for lines controls Ringing service, Restriction service and Routing service for its assigned lines; a control telephone for telephones controls Restriction service and Routing service for its assigned telephones. Assign a control telephone for each external line and telephone.

Use , **CHANGE**, , and the dial pad to program the internal number of the control telephone for each line and each telephone.

Tips

Only the external lines and telephones programmed with a control telephone can be placed into a Service Mode.

You can assign a control telephone to more than one external line or telephone, but a line or telephone cannot be assigned to more than one control telephone.

You can only apply a service in one mode at any one time to all external lines and telephones controlled by a given control telephone. You can have several modes active, as long as they are using different services.

The default control telephone for all lines and telephones is **221**.

One recommendation is to have one control telephone for all lines and a different control telephone for all telephones.

Ringling service

Indicate how Ringling service should be activated for each of the Service Modes.

Use , , and **CHANGE** to change each Service Mode setting: **Off**, **Automatic**, or **Manual**.

Manual allows you to turn the service on and off at any time from a control telephone using the Ringling service feature code.

Automatic allows you to preassign a stop and start time for a mode during which the service is active. You are still able to start and stop the service by entering the appropriate Service Modes feature code at a control telephone. If you select this setting, you will have to program start and stop times. See the section on Mode times for information on programming times.

Off prevents the service from being activated.

Trunk answer

Trunk answer allows you to answer, from any telephone, an external call that is ringing at another telephone in your office. This is useful if the other telephones have not been assigned the same lines as the telephone you are using to answer the call.

Press **CHANGE** to select the setting: **Y** (Yes) or **N** (No).

Tips

You can change the Trunk Answer setting only if Ringling service is set to **Manual** or **Automatic**.

Extra-dial telephone

Extra-dial telephone allows you to assign an additional direct-dial telephone in the Norstar system for each operational Service Mode.

Use **CHANGE** and the dial pad to enter the internal telephone number of the extra-dial telephone.

Tips

The extra-dial telephone is activated during a Service Mode by entering the Ringing service feature code from a direct-dial telephone. This does not activate the Ringing service unless the direct-dial telephone is also a control telephone.

Ringing sets

For each line, you can assign additional telephones and an auxiliary ringer to ring for incoming calls.

Use , **ADD** and the dial pad to enter the internal telephone numbers of the additional ringing telephones for each line.

Auxiliary ringer

Indicate whether the auxiliary ringer (if installed) also rings when Ringing service is on. Press **CHANGE** to select the setting: **Y** (Yes) or **N** (No).

Tips

The default ringing telephone is **221**. This means that all lines ring at telephone 221 when Ringing service is on.

You can use **COPY** and the dial pad to copy Ringing set and Auxiliary ringer programming from one line to another.

If you have an auxiliary ringer programmed to ring for calls on an external line, and you transfer a call on that line without announcing the transfer, the auxiliary ringer will ring for the call transfer.

Restriction service

Indicate how the alternate dialing restrictions should be activated for each of the Service Modes.

Use , , and **CHANGE** to change each Service Mode setting: **Off**, Automatic, or Manual.

See the section in this chapter on Ringing service for descriptions of the three settings.

See the section on Line abilities in the Capabilities chapter for instructions to assign dialing restrictions to the Service Modes.

Routing service

Indicate how alternate call routing should be activated for each of the Service Modes.

Use , , and **CHANGE** to change the Service Mode setting: **Off**, Automatic, or Manual.

See the section in this chapter on Ringing service for descriptions of the three settings.

The routes have already been assigned to the Service Modes by your customer service representative. Routes were selected to take advantage of the least expensive routing available.

Overflow

Indicate whether the system should select the normal route if the programmed route is busy.

Use , and **CHANGE** to toggle the Overflow setting between **No** and Yes.

Tips

If when you make a call the programmed route is busy, you hear the expensive route warning tone and see a display indicating that an expensive route will be used. To avoid using the normal route, release your call.

Passwords

The Administration password allows access to Administration programming. It prevents unauthorized or unintentional changes to settings. To ensure security, distribute the password only to selected personnel. Keep a record of your password in a secure place, and change it periodically.

The password is a one to six-digit number. The default Administration password is , which is the same as .

Use , **CHANGE** and the dial pad to enter the new Administration password. Press **OK** to accept the programmed password.

Tips

The password is easier to remember if the digits correspond to the letters in a word.

If you forget the Administration password, you cannot access Administration programming. Call your customer service representative to assign a new Administration password.

If you press **CHANGE** but do not enter a new password, the existing password is erased. Anyone can then access Administration programming without a password.

Log Defaults

If you subscribe to Call Display services, external calls can be tracked in a Call Log. Log Defaults programming customizes how log space is allocated to telephones in the system.

8. Log Defaults
Reset all logs
Space/log

Reset all logs

Reset all logs allows you to reallocate the Call Log space equally to all telephones in your system.

Use and the dial pad to enter the space allocation for the Call Log at each telephone. Press **OK** to accept the settings and end Administration programming. The system automatically reallocates Log space.

Tips

Use this heading only if you want to allocate an equal amount of log space to all the telephones in your system. If you want to assign specific amounts of log space to individual telephones use **Log Space** in **9. Call Services**.

Reallocating Call Log space may destroy Call Log data at telephones that lose space.

There are 600 Call Log spaces available in the system. There are no spaces allocated by default. Changing the space allocation using Log Defaults defines the log space available to all telephones in the system. Any remaining unassigned log space is available in a log pool, and can be reallocated in Call Services programming.

Call Services

If you subscribe to Call Display services, external calls are identified on the display. Call Services programming allows you to customize how this information is used.

9. Call Services	
Auto Call Info	
Show line: _	
Line 001	None
Set services	
Show set: _	
Autolog/ShowVMsg	
Line001	
Logging set	N
Show extl VMsg	N
Log space	
Log:0	Pool:600
Log passwr	None
1stDisplay	Name
VMsg centr tel#s	
VMsg center 1	
Max. 24 digits	
VMsg center 2	
VMsg center 3	
VMsg center 4	
VMsg center 5	
VMsg tel#s -> lines	
Show line: _	
L001 VMsgrCentr	1

Auto Call Info

Auto Call Info allows you to specify which telephone displays the Call Display information when a call is ringing on an external line. (After the call is answered, Call Display information is always shown at the telephone that answered the call.)

For each line, use **SHOW**, **CHANGE** and the dial pad to enter the internal number of the telephone to display Call Display information.

Tips

In order for a telephone to display the Call Display information for calls on an external line, it must also be programmed to ring for that line.

Set services

Set services programming allows you to customize how Call Display information is used at each telephone. Begin by entering the telephone's internal number. With the display reading Autolog/ShowVMsg, press SHOW to view the settings for each line assigned to the telephone.

Logging set

Logging set allows you to specify whether the telephone automatically logs Call Display information for calls on an external line. The line must appear on that telephone but it does not have to be a ringing line. Press CHANGE to select the setting: **N** (No) or **Y** (Yes).

Show extl VMsg

If you subscribe to a voice message service, you can access that service through your Norstar system. Show extl VMsg lets you set whether your Norstar telephone will indicate when you have a voice message waiting for you on a particular line. The line must appear on that telephone. Press CHANGE to select the setting: **N** (No) or **Y** (Yes).

Log space

Log space determines the number of items that can be stored in the Call Log for each telephone. Use Show , ADD and REMOVE to redistribute the log space. There is no log space assigned by default.

Tips

There must be space available in the log pool in order for you to add space to a Call Log.

System-wide log space allocation is performed in Log Defaults programming. If you want to allocate the same log space to all telephones, it may be appropriate to use Log Defaults programming instead.

Log password

Log password allows you to clear any Call Log password programmed with the Call Log feature. Press **CHANGE** to clear the programmed password.

Tips

You program a Call Log password using the Call Log Password feature. See the Telephone features chapter for more information.

1stDisplay

Depending on the services you subscribe to, Call Display information may contain up to three parts: the name of the caller, the number of the caller, and the name of the line in your Norstar system that the call is on. For each telephone, you can determine which information is displayed first. Press **CHANGE** to select the setting: **Name**, **Number** or **Line**.

Tips

The Call Information feature is used to display and scroll through all of the Call Display information: the caller name, number and line number. See the Telephone features chapter for more information.

You may see **Unknown name** or **Unknown number** on the display if the information is not available from your telephone company. You may see **Private name** or **Private number** on the display if the caller blocks that information.

VMsg centr tel#s

If you subscribe to a voice message service, you can access that service through your Norstar system. This setting specifies the external telephone numbers that can be dialed by the Message feature to retrieve voice messages. Use **Show**, **Next**, **CHANGE**, and the dial pad to enter the external telephone number.

Tips

The display does not show that external voice messages are waiting unless Show extl VMsg is set to Yes.

The number that is dialed by the Message feature for a particular line is determined by VMsg tel#s lines.

You can program up to five voice message center numbers, but most systems require only one. .

VMsg tel#s lines

If you subscribe to a voice message service, you can specify which voice message center is used for each external line that can receive message waiting indication. For each line, press **CHANGE** to select the setting: 1, 2, 3, 4, 5, or N (None).

Reviewing programming

Set Profile and Line Profile let you view but not change the programming settings for each Norstar telephone and line.

As many as four people in the Norstar system can use Set Profile or Line Profile at the same time. You access Set Profile or Line Profile from any M7310 or M7324 telephone, even while you are on a call.

If someone is using Configuration or Administration programming, you can still access Set Profile and Line Profile from another Norstar telephone. The latest programming changes can be seen as soon as they are made.

Set Profile and Line Profile let you review the following Configuration and Administration programming headings:

Set Profile	Line Profile
Set name	Line name
Line Access	Trunk data (physical lines only)
Set abilities	Received number (target lines only)
Set services	Line data
	Line abilities (physical lines only)
	Service Modes
	Call information
	Voice message center

Viewing the programming for a telephone

From an M7310 or M7324 telephone:

1. Press * * S E T . The display reads **Show set:**.
2. Enter the internal number of the telephone whose programming you want to review. The display shows the internal number and name.
3. Use **BACK**, **SHOW**, and **NEXT** to navigate through the settings.

Viewing the programming for a line

From an M7310 or M7324 telephone:

1. Press * * L I N E The display reads **Show line:**.
2. Enter the number of the line whose programming you want to review. The display shows the line number and name.
3. Use **BACK**, **SHOW**, and **NEXT** to navigate through the settings.

Programming reminders

This section contains a number of programming reminders designed to help you record your programming and distribute the information to your co-workers. Photocopy the appropriate pages, then fill in the information.

You can check the programmed setting in the *Programming Record* and or by using Set Profile and Line Profile.

Prime telephones

Prime telephone operator	
Internal number	_____
Lines answered at the prime telephone	_____
_____	_____

Prime telephone operator	
Internal number	_____
Lines answered at the prime telephone	_____
_____	_____

Prime telephone operator	
Internal number	_____
Lines answered at the prime telephone	_____
_____	_____

Prime telephone operator	
Internal number	_____
Lines answered at the prime telephone	_____
_____	_____

Central answering positions

CAP operator	Internal number

Page zones

Page zone	Location
1	
2	
3	
4	
5	
6	

Line pools

Pool	Access code	Use
A	-----	
B	-----	
C	-----	
D	-----	
E	-----	
F	-----	
G	-----	
H	-----	
I	-----	
J	-----	
K	-----	
L	-----	
M	-----	
N	-----	
O	-----	

Miscellaneous programming

Direct-dial telephones	1 _____	2 _____
	3 _____	4 _____
	5 _____	
DISA DN (used to change COS)	_____	
Direct-dial digit	—	
Call Park prefix	—	
Dial first to make external calls	—	

Call Pickup groups

Pickup group	Names of group members
—	
—	
—	

Service Modes

Service Mode 1	Service Mode 2	Service Mode 3
Name	Name	Name
_____	_____	_____
Monday Start --:-- Stop --:--	Monday Start --:-- Stop --:--	Monday Start --:-- Stop --:--
Tuesday Start --:-- Stop --:--	Tuesday Start --:-- Stop --:--	Tuesday Start --:-- Stop --:--
Wednesday Start --:-- Stop --:--	Wednesday Start --:-- Stop --:--	Wednesday Start --:-- Stop --:--
Thursday Start --:-- Stop --:--	Thursday Start --:-- Stop --:--	Thursday Start --:-- Stop --:--
Friday Start --:-- Stop --:--	Friday Start --:-- Stop --:--	Friday Start --:-- Stop --:--
Saturday Start --:-- Stop --:--	Saturday Start --:-- Stop --:--	Saturday Start --:-- Stop --:--
Sunday Start --:-- Stop --:--	Sunday Start --:-- Stop --:--	Sunday Start --:-- Stop --:--

Service Mode 4	Service Mode 5	Service Mode 6
Name	Name	Name
_____	_____	_____
Monday	Monday	Monday
Start __:--	Start __:--	Start __:--
Stop __:--	Stop __:--	Stop __:--
Tuesday	Tuesday	Tuesday
Start __:--	Start __:--	Start __:--
Stop __:--	Stop __:--	Stop __:--
Wednesday	Wednesday	Wednesday
Start __:--	Start __:--	Start __:--
Stop __:--	Stop __:--	Stop __:--
Thursday	Thursday	Thursday
Start __:--	Start __:--	Start __:--
Stop __:--	Stop __:--	Stop __:--
Friday	Friday	Friday
Start __:--	Start __:--	Start __:--
Stop __:--	Stop __:--	Stop __:--
Saturday	Saturday	Saturday
Start __:--	Start __:--	Start __:--
Stop __:--	Stop __:--	Stop __:--
Sunday	Sunday	Sunday
Start __:--	Start __:--	Start __:--
Stop __:--	Stop __:--	Stop __:--

Telephone basics

This section covers the basic features of your Norstar telephone and optional equipment that may be attached to it.

Answer buttons

You can use an answer button to monitor calls on another person's telephone. All calls to the monitored telephone appear on the answer button. The calls may also ring at the telephone with the answer button, depending on system programming. Answer buttons are useful for a secretary who monitors incoming calls for one or several managers.

If more than one call is ringing at the manager's telephone, the first call appears on the secretary's answer button. Any subsequent calls appear on intercom buttons if they are available.

More than one secretary may have an answer button for a single manager. This allows two or more secretaries to handle calls for a busy manager.

Each telephone can handle calls for up to four other people using separate answer buttons for each person.

You cannot make calls using answer buttons.

Feature button

You use the Feature button to invoke Norstar features. See the Telephone features chapter.

Headset

A headset lets you keep both hands free while you are on a call without others overhearing your telephone conversations.

If you plug a headset into your telephone while you are on a call, your telephone's microphone and speaker (or your receiver if you are on a regular call) are turned off and your headset microphone and earpiece are turned on.

You must have the Handsfree feature assigned to your telephone if you wish to use a headset. You cannot use a headset on an M7100 telephone.

While you are using the headset, the receiver and the switch in the telephone cradle do not work.

Using a headset

To answer a call, press  .

While on a call using the headset, press  to turn your headset on and off.

To change to a handsfree call while you are on a call using your headset, unplug your headset. Your telephone's microphone and speaker turn on and the call becomes a handsfree call. (It is a good idea to put the call on hold while you do this.)

You may see this display when you try to use a headset.

Need Handsfree	You are attempting to use a headset, but Full Handsfree is not programmed for your telephone, or you have accidentally plugged your telephone receiver into the headset jack on the bottom of the telephone.
-----------------------	--

Hearing aid compatibility

The receivers on all Norstar telephones are compatible with hearing aids as defined in the FCC rules, Part 68, section 68.316. Not all hearing aids are optimized for use with a telephone.

Hold button

You use the Hold button to put calls on hold. See the Hold section in the Telephone features chapter. It is also used in place of **OK** on telephones with one-line displays.

Incoming line group buttons

You have one incoming line group button for each incoming line group assigned to your telephone. You use an incoming line group buttons just like line button, except you cannot use it to make a call.

Line buttons

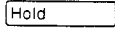
You have one line button for each line assigned to your telephone. Press the line button to select the line you want to answer or use to make a call. Having several line buttons allows you immediate access to more than one line. The M7100 telephone does not have line buttons and can have a maximum of two lines. Press  to switch between its two lines, one active and one on hold.

Memory buttons

Memory buttons are the buttons with indicators on the M7208, M7310, and M7324 telephones, and the dual buttons without indicators on the M7310 telephone. There is also a single memory button, without an indicator, on the M7100 telephone. Memory buttons can be used as answer, autodial, line, incoming line group, and programmed feature buttons. Line, incoming line group, intercom and answer buttons must have indicators.



Autodial buttons

Autodial buttons let you dial numbers by pressing a single button. See the Autodial section in the Telephone features chapter.

Programmed feature buttons

Programmed feature buttons allow you to invoke Norstar features by pressing a single button. See Customizing your telephone in this chapter.

Release button

Pressing  ends a call. You do not have to put the receiver down.  also ends feature programming.

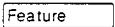
While you are on a call, do not press  to end a feature you are using. If you do, you will disconnect the call. Use  instead.

Volume bar

The volume bar controls the volume of the receiver, telephone ring, handsfree speaker, and headset. Press either end of the volume bar  to adjust the volume.



Wall mounting

Norstar telephones can be mounted on a wall. Contact the installer or customer service representative if you wish to have any telephones in your system wall-mounted.

Answering the telephone

Your Norstar telephone can receive many different types of calls. Your telephone display tells you what type of call you are receiving.

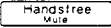
There are many ways to answer a call, depending on Administration programming and the type of call you are receiving:

- Pick up the receiver.
- Pick up the receiver and press a line button (if the call is not on your prime line).
- Press  (to talk without using the receiver). See Handsfree in this section for more information.
- Press  and press a line button (to talk without the receiver and if the call is not on your prime line).
- Press a line button (to talk without the receiver and if Automatic Handsfree is assigned to your telephone).
- Just speak (to answer a voice call, which is described in the Telephone features chapter).

Call Display information

If you have subscribed to Call Display services from your local telephone company, one line of information about an external caller is displayed after you answer. If your telephone is programmed to receive Call Display information automatically, that information is shown before you answer. Depending on the setting in Administration programming and the external information available, either the caller's name or telephone number is displayed.

When you transfer an external call to another Norstar user, this information is displayed on the recipient's telephone.

There may be a delay between the time your telephone rings and when Call Display information is available. If you answer a call before the Call Display information arrives, that information may not be available for the call.

Call Park retrieval

You can dial a retrieval code from any telephone in the system to pick up a call that has been parked. See the Telephone features chapter for instructions.

Call Pickup

Call Pickup lets you use your telephone to answer a call that is ringing at someone else's telephone. See the Telephone features chapter for instructions.

Call Queuing

Call Queuing allows you to answer the call with the highest priority when you have more than one call ringing at your telephone. See the Telephone features chapter for instructions.

Callback

When you direct a call you have answered to another telephone, the system monitors the call to make sure someone answers it. If no one answers the call within a programmable length of time, the system directs it back to you.

Callback generates a variety of displays. Most occur after a programmable delay and are listed in this section. Some occur immediately if the telephone to which you are directing a call is out of service or otherwise unavailable. These are listed with the descriptions of the features in which they occur.

Delayed Ring Transfer

If no one answers a call within a programmable length of time, the system transfers the call to the prime telephone.

Do Not Disturb

If you do not wish to receive calls, turn on Do Not Disturb. See the Telephone features chapter for instructions.

Handsfree

You can answer calls without lifting the receiver.

1. Press the line button for the ringing call. (This step is not necessary if you have a prime line assigned to your telephone.)

2. Press . The telephone's internal microphone and speaker are automatically turned on.

Voice Call Deny

If you do not wish to receive voice calls, turn on Voice Call Deny. See the Telephone features chapter for instructions.

Tips

A prime telephone receives calls that go unanswered at other telephones. For more information, see Special telephones.

What line indicators mean

- | | |
|---|---|
| ▶ Flashing on and off for equal lengths of time | There is an incoming call on the line. |
| ▶ Flashing on and off more quickly | You have placed a call on hold. |
| ▶ Flashing on for longer than off | Someone else has put a call on hold on that line. |
| ▶ On, not flashing | You are connected to the call on that line or the line is in use elsewhere. |
| Off | The line is free. |

Rings you may hear

- | | |
|---------------------------------|--|
| A double beep every ten seconds | A call has been camped to your telephone. |
| A long single ring | There is an external call on the line for you. |
| A shorter double ring | There is an internal call on the line for you or a call is being transferred to you. |
| A brief single ring | A call is being redirected on one of your redirected lines. You cannot answer this call. See Line Redirection in the Telephone features chapter. |
| Three beeps descending in tone | You are receiving a priority call. |

Displays

You may see some of the following displays when you receive a call on your telephone and while you are answering that call:

S	This indicates a long-distance call. (May be available with Call Display services.)
247>221	Either you are receiving an internal call from telephone 247 forwarded by telephone 221 or you have an answer button for telephone 221 and an internal call from 247 is ringing on 221.
221 TRANSFER	You are connected to an internal call. Press <u>TRANSFER</u> to transfer the call.
221 calling	You are receiving a call from telephone 221.
Call 221? YES NO	You have received a Ring Again offer for a call to an internal telephone. Press the flashing internal line button or <u>YES</u> to call the number again. On the M7100 telephone, just lift the receiver. Otherwise, press <u>NO</u> or wait 30 seconds for the Ring Again offer to expire. For an explanation of Ring Again, see the Telephone features chapter.
Camped: 221 CALLBACK	The person to whom you camped the call did not answer it. The call has come back to you. Press the line button or <u>CALLBACK</u> to reconnect to the call.
Line001 TRANSFER	You are connected to an external call. Press <u>TRANSFER</u> to transfer the call.
Line001>221	Either you are receiving an external call forwarded from telephone 221 or you have an answer button for telephone 221 and an external call is ringing on that telephone.
Line001 transfer	The call on line 001 is being transferred to you by someone else in your Norstar system.
Line001 waiting	A camped call is waiting. Press the line button or use Call Queuing to answer the call. Press <input type="text" value="Hold"/> if you have an M7100 telephone.

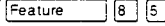
No calls waiting	You tried to use Call Queuing but no call was ringing at your telephone.
No line selected	There is no call ringing at your telephone. If you have a flashing line button but your telephone is not ringing, press the line button to answer the call on that line.
Not in service	The telephone you directed a call to is not in service or is otherwise unavailable. The call is returned to your telephone.
Parked call CALLBACK	Nobody answered the call you parked. The call has come back to you.
Pick up receiver	You have used the Call Queuing feature without picking up the receiver. Auto Handsfree has not been assigned to your telephone. You must use the receiver or  to answer a call.
Priority > 221 BLOCK	You are receiving a priority call. If you are on another call, inform the person you are speaking to that the call is about to be put on hold. Press the flashing line indicator of the priority call or wait until the call connects automatically (in eight seconds). The priority call goes through when you hear the next beep. Your active call is placed on Exclusive Hold. It will be reconnected automatically when the priority call ends (unless you transfer the priority call, in which case you must press the line button of your original call to reconnect). Use DND () or press BLOCK to reject a priority call.
Release a call	You have no free line buttons on which to receive a call. Release one of your current calls and try again to answer the incoming call.
Use line pool? YES NO	You have received a Ring Again offer for a line pool. Press the flashing internal line button or YES to use the line pool. On the M7100 telephone, just lift the receiver. Otherwise, press NO or wait 30 seconds for the Ring Again offer to expire.

Prime telephone displays

If yours is a prime telephone, you may see the following displays:

DND from 221	The person at telephone 221 has forwarded a call to you using Do Not Disturb.
DND transfer	The system has transferred a call to you from a telephone in Do Not Disturb mode.
DRT Line001	Nobody answered this call so the system transferred it to you.
Line001 callback CALLBACK	Someone has camped, parked or transferred a call on line 001, but no one has answered it. Press CALLBACK or the line button to connect to the call.
Line001 to prime	There is no telephone that can receive a call on line 001 so the system has transferred it to you.
Line015>Line187	The call coming in on line 015 was intended for target line 187. Line 187 is busy so the call has come to you.

Tips



There are three indications of an incoming call: ringing, a line button flashing, and a message on the display. You will not necessarily receive all three indications for any particular call. You may have a line that has been set up not to ring at your telephone. If so, you will see only a flashing line button. If there is no button free for a camped call to appear, you will get a special ring and a message on your display, but no line button will flash. If someone makes a voice call to you, you will hear a beep followed by their voice. There are many possible combinations, depending on how your system is set up. See Lines in the System features section for more information on the use of lines.

If you receive a priority call and your telephone has no free internal line buttons, you cannot transfer the call or do anything else except release it.

On M7100 telephones, you can answer a second call by pressing **Hold** . Your active call is put on hold and you are connected to the waiting call. You can have no more than two calls at a time.

Making calls

There are many ways to make a call. Depending on Administration programming and the type of call, these are the ways to make a call:

- Pick up the receiver and dial.
Norstar supports three methods of dialing. See Dialing modes in the section on Customizing your telephone and in the Telephone features chapter.
- Pick up the receiver, press a line button, and dial (if the call is not on your prime line).
- Press  and dial (to talk without using the receiver). See Handsfree/Mute in this section for more information.
- Press , press a line button, and dial (to talk without the receiver and if the call is not on your prime line).
- Press a line button and dial (to talk without the receiver and if Automatic Handsfree is assigned to your telephone).
- Use one of the features that make dialing easier.

The features that make dialing easier are described in this section.

Autodial

You can program telephone numbers onto memory buttons for one-touch dialing. See the Telephone features chapter for instructions.

Direct-dial telephone

You can dial a direct-dial telephone with a single digit. The direct-dial telephone is usually in a central location, such as a receptionist's desk. It can be a telephone in your Norstar system, or outside your system in the private or public network. If the direct-dial telephone is in your Norstar system, it also often functions as a prime telephone or central answering position (CAP).

Your system can have up to five direct-dial telephones programmed in Administration.

Tips

The direct-dial digit is programmed by the installer or customer service representative.

You cannot forward calls to a direct-dial telephone that is outside your Norstar system.

External line access code

The external line access code is the number you dial to get an external line. You may need to use an external line access code if your prime line is an internal line and you have no external line buttons. The code connects you to a line pool through your internal line.

If your prime line is an external line, or if you select an external line on your telephone, you will not need an external line access code.

Your installer or customer service representative assigns the external line access code in Configuration programming.

Handsfree/Mute

Making calls without lifting the receiver

You can make calls without lifting the receiver.

1. If you don't have a prime line assigned to your telephone, press a line button.
2. Press . The telephone's internal microphone and speaker are automatically turned on.
3. Dial your call.
4. Speak normally.

Muting handsfree

You can switch off the telephone microphone so that you can speak privately to someone in your office while you are on a handsfree call.

1. Press . The microphone is turned off.

You can turn the microphone back on again and continue your handsfree call.

1. Press .

Changing a regular call to handsfree

You can turn any regular call into a handsfree call.

1. Press  and hang up the receiver.

Changing a handsfree to a regular call

You can turn a handsfree call into a regular call.

1. Lift the receiver.

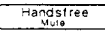

Tips

The indicator next to  is solid when you are in handsfree mode. It flashes when you mute the microphone.

In open-concept environments, use the receiver when handsfree communication is not necessary or when you need privacy during a call, or alternatively, use a headset.

Direct your voice toward the telephone. The closer you are to the telephone, the easier it is for the microphone to transmit your voice clearly to your listener.

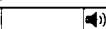
Wait for your caller to finish speaking before you speak. The microphone and speaker cannot both be on at once. Your caller's voice may be cut off if you both speak at the same time. Noises such as a tapping pencil could be loud enough to turn on your microphone and cut off your caller's speech.

To prevent a possible echo, keep the area around your telephone free of paper and other objects that might screen your microphone. Turning down the microphone's volume (press   ) while speaking) also prevents echo.

Place the telephone so that any unavoidable local noise (such as an air conditioner) is behind it. This limits the amount of disruptive background noise.

A Handsfree/Mute button is assigned to a telephone by the system coordinator in Administration programming.

The Handsfree/Mute feature is not available on M7100 telephones.

Last Number Redial

You can redial the last number you called with a single button. See the Telephone features chapter for instructions.

Line pool access code

A line pool access code is a number you dial to get a line pool. You can have several different line pools for your system, each one giving you access to a different set of external lines. It is one way of sharing lines across telephones in a system.

Your installer or customer service representative programs the line pool access codes.

Saved Number Redial

If there is a number that you dial frequently, you can store it and then dial it using the Saved Number Redial feature. See the Telephone features chapter for instructions.

Speed Dial

You can dial a programmed number using the Speed Dial feature. Speed dial codes 01 to 70 are the same for your whole system, and are programmed by the system coordinator. See the Speed Dial section of the Programming chapter for instructions to program Speed dial codes 01 to 70.

Speed dial codes 71 to 94 are for your personal use. See Speed Dial in the Telephone features chapter for instructions to program and use Speed Dial.

Voice Call

You can call another telephone in your system without making it ring. See the Telephone features chapter for instructions.

Displays

221 busy
PRIORITY LATER

The telephone you have called has no internal lines available. Press LATER to use the Ring Again or Message features or press PRIORITY to make a priority call.

9_
QUIT BKSP

You are dialing using Pre-Dial. To erase an incorrect digit, press the left end of  or BKSP. When the number is complete, select a line or lift the receiver.

<p>95551234 TRANSFER</p>	<p>This prompt remains on your display as long as you are on a call you have dialed. To transfer the call, press <u>TRANSFER</u>.</p>
<p>Already joined</p>	<p>Your telephone is already connected to the telephone you are trying to call. Check your active line buttons, and return to that call.</p>
<p>Calling 221 LATER</p>	<p>Wait for the telephone to be answered, or press <u>LATER</u> to use the Ring Again or Messages features.</p>
<p>Calling 221 PRIORITY LATER</p>	<p>Wait for the telephone to be answered. If no one answers, press <u>LATER</u> to use the Ring Again or Messages features, or press <u>PRIORITY</u> to make a priority call.</p>
<p>Can't ring again</p>	<p>You cannot use Ring Again on your current call. You can only use Ring Again while you have a busy signal on an internal call or line pool request or while an internal call is ringing.</p>
<p>Do not disturb PRIORITY LATER</p>	<p>The telephone you are calling is in Do Not Disturb mode. Press <u>LATER</u> to use the Ring Again or Messages features, or press <u>PRIORITY</u> to make a priority call.</p>
<p>Expensive route</p>	<p>You have dialed a number, but the least expensive route that the system is programmed to use is busy. Unless you release the call, it will go through on a more expensive route.</p>
<p>Hidden number</p>	<p>The last number you dialed or the number you saved for Saved Number Redial was a speed dial number that displayed a name rather than the number. The number will be dialed correctly, but you cannot see it.</p>
<p>In use: 221</p>	<p>The line you have chosen is in use at another telephone. Use a different line, or wait until the line is free.</p>
<p>Incoming only</p>	<p>You have pressed a button that is used for incoming calls only. Press a line, line pool, or intercom button.</p>
<p>Invalid number</p>	<p>You have entered a number that does not exist.</p>

Line denied	You have attempted to use someone else's private line.
Line in use	The line you have chosen is in use. Try another. If the line remains in use and never seems to clear, it may be hung. See Lines in the System Features section for information on hung lines.
Line001 TRANSFER	Enter the digits of the number you want to dial.
No button free	You have tried to make or receive a call when no line button was available.
No last number	You have not dialed an external telephone number since the last power interruption or system reset.
No line selected	Either you have no prime line or your prime line is busy. Select a line manually before dialing.
No number saved	You have tried to save the number of an incoming call. You can only save numbers that you have dialed yourself.
No saved number	You have tried to use Saved Number Redial, but have not first saved a telephone number. The Saved Number Redial memory is empty.
Not in service	You have entered the number of a telephone that is not in service.
On another call LATER	The telephone you have called is on another call. Press <u>LATER</u> to use the Ring Again or Message features.
Restricted call	The call you are trying to make is not allowed by your Class of Service. Make your call on a line or telephone that is not restricted, or use a Class of Service password to bypass the restriction.
Ring Again? YES NO EXIT	Press <u>YES</u> to use Ring Again. Press <u>NO</u> to send a message. See Message and Ring Again in the Telephone features chapter.

Select a line

Either you have no prime line, or the prime line is in use, or the line programmed for an autodial number, speed dial number, or Hotline is in use. Select a line and dial again.

Send message?
YES NO

Press YES to send a message. See Messages in the Telephone features chapter.

Your number

You have dialed your own number.

Customizing your telephone

You can change the way a telephone works in several ways. Some of the following features are assigned to telephones in Administration programming; others can be programmed at individual telephones.

Automatic Handsfree

Automatic Handsfree lets you make or answer a call without having to pick up the receiver or press . The telephone's internal microphone and speaker turn on automatically when you press a line or intercom button to make or answer a call.

The system coordinator assigns Automatic Handsfree capability to a telephone in Administration programming.

This feature is not available on M7100 telephones.

Button Inquiry

* 0

You can check the function of any line, intercom, or memory button on your Norstar telephone.

1. Press * 0.
2. For all telephones other than the M7100 telephone, press the button you want to know about.
3. Read the display.

Dialing modes

Your Norstar telephone has three dialing modes:

- Automatic Dial lets you dial a number as soon as you press a programmed memory button or dial-pad button. You do not have to select a line, lift the receiver, or press .
- Pre-Dial lets you dial a number first and then select a line. This gives you a chance to check the number and change it if necessary.
- Standard Dial lets you select a line first and then dial a number.

You can change the dialing mode for your telephone at any time. See the Telephone features chapter for instructions.

Display contrast

You can set the contrast level of your telephone display. See the Telephone features chapter for instructions.

Feature programming

Feature * 3

You can program a feature code onto a memory button.

1. Press Feature * 3.
2. For all telephones other than the M7100 telephone, press the memory button you want to program.
3. Enter the feature code you want to program onto the button.

Erasing a programmed feature button

You can erase a memory button.

1. Press Feature * 1.
2. For all telephones other than the M7100 telephone, press the button.
3. Press Hold or OK to erase the button.

Displays

<Feature name>
SHOW OK

The name of the feature assigned to a button is displayed when you press the button.

SHOW appears when there is more information available. Press # or SHOW for additional information.

1234567890123...
VIEW→ OK

Press # or press VIEW→ or ←VIEW to view a number that is too long to fit on the display. Press Hold or OK when you are finished.

Enter code:

If you are checking a speed dial button, enter the two-digit speed dial code that you want to check.

F_
QUIT CLEAR

Enter the feature code, or press Ris or QUIT to quit programming or CLEAR to clear out the numbers you have entered. The system accepts the entry as soon as you enter a valid feature code.

Feature code:
QUIT

Press Feature and enter the feature code you want to program onto the button. You cannot enter invalid codes

Feature moved	You have programmed a button with a feature that was already programmed onto another button. The feature has moved to the button you just programmed. Its original button is blank.
Hold or release	You cannot program an autodial or feature button while you are on a call.
Press a button EXIT	Press the button you want to check. Press <input type="text" value="Feature"/> or EXIT when you are finished.
Program and HOLD	Enter the number you want to program and press <input type="text" value="Hold"/> . To erase the button, just press <input type="text" value="Hold"/> .
Program and OK QUIT OK	Enter the number you want to program and press OK . To erase the button, just press <input type="text" value="Hold"/> or OK .
Release calls	You have tried to use Button Inquiry while you are on a call or have calls on hold.

Tips

You can enter a feature code by pressing a memory button programmed with that feature code. In some cases, pressing the button a second time cancels the feature.

When you program a button with the line pool feature code, you must enter a line pool access code after the feature code. The programmed line pool button accesses a specific line pool, not the line pool feature.

When you are labeling or replacing a button cap, use Button Inquiry (*) so that you don't accidentally activate a feature.

On the M7100 telephone, Button Inquiry shows your internal number, and the function assigned to your single memory button.

Any memory button not programmed as an external or internal line, target line, answer button, or Handsfree/Mute button, is available for programming features. You cannot erase line, incoming line group, intercom, answer, or Handsfree/Mute buttons.

The following feature codes cannot be programmed onto a memory button: Long Tones and any code beginning with * except Language Choice and Contrast Adjustment.

Language choice

You can select one of three languages for your Norstar telephone. See the Telephone features chapter for instructions.

Moving line buttons

You can move external lines to different buttons on your telephone. You can use this feature to arrange your lines in the way that makes the most sense to you. See the Telephone features chapter for instructions.

Pulse or tone dialing

If your external lines use pulse dialing, you can switch temporarily to tone dialing to communicate with devices such as answering machines, to access the features that PBX systems may offer, or to use another Norstar system remotely. (See Using Norstar remotely in this chapter for more information).

1. Press # while on an active line. Once you hang up, your telephone returns to pulse dialing.

Special telephones

You can assign several special functions to the telephones in your Norstar system. Except where noted, you do not need special hardware. A special function is assigned to a telephone either by your installer or customer service representative or by the system coordinator.

Alarm telephone

An alarm telephone displays Norstar's system alarm codes, should they occur. It is a Norstar telephone with a two-line display (M7310 or M7324 telephones) that the installer or customer service representative has assigned as an alarm telephone.

If an alarm message appears on the alarm telephone's display, follow these instructions:

1. Record the alarm number.
2. Press **TIME** and record the time displayed.
3. Call your installer or customer service representative and report the alarm code.
4. After speaking to your installer or customer service representative, press **CLEAR**.

Displays

Alarm: 61-4-2
TIME CLEAR

Report this alarm and the time it occurred to your installer or customer service representative.

Central answering position

A central answering position (CAP) is a Norstar M7324 telephone that your installer or customer service representative programmed as a CAP. There can be from one to five CAPs in a Norstar system. It is best if the CAP is also the prime telephone and direct-dial telephone for the lines and telephones it serves.

You can connect one or two Norstar CAP modules to the CAP to increase the number of lines it can handle to 120.

The CAP module displays the busy and not busy status of the telephones in your system by using the triangular indicators beside internal autodial buttons.

You can send up to 30 messages from a CAP.

For more information, see the *Norstar Central Answering Position User Card*.

Control telephone

The control telephone lets you place the telephones and external lines for which it has responsibility into and out of service modes. See Service Modes in the Telephone features chapter.

Direct-dial telephone

You can dial a direct-dial telephone with a single digit. The direct-dial telephone is usually in a central location, such as a receptionist's desk. It is usually a prime telephone and a central answering position (CAP).

There can be up to five direct-dial telephones inside and outside your system, but each telephone in the system can reach just one direct-dial telephone. There is a single direct-dial digit for the whole system that lets each telephone call its assigned direct-dial telephone.

Each direct-dial telephone can send up to 30 messages and can invoke service modes to activate the extra-dial telephone.

Your installer or customer service representative sets up direct-dial telephones. The system coordinator assigns telephones to direct-dial telephones in Administration programming.

Emergency telephone

The emergency telephone is a single-line telephone (not a Norstar telephone) that functions independently of the Norstar system. You can use the emergency telephone when your Norstar system is not working. If there is a power-failure, or a system error that disables telephone service, the emergency telephone provides basic telephone service on an external line.

The emergency telephone is usually located near the Key Service Unit (KSU). Each KSU can have two emergency telephones; each Trunk Module can have one additional emergency telephone.

Depending on your hardware, your system may not support emergency telephones. See your customer service representative for information.

Extra-dial telephone

In *Service Mode's Ringing service*, a second telephone can be assigned to ring on calls made to a direct-dial telephone. There may be one extra-dial telephone for each service mode. The system coordinator programs *Service Modes in Administration programming*.

Hotline telephone

You can call a programmed internal or external telephone number simply by picking up the receiver of the hotline telephone (or by pressing ).

Put a notice by the hotline telephone to let people know which number will be dialed when they lift the receiver.

If the hotline telephone is set up to dial an external number using the prime line, there must be an external prime line assigned to the telephone. If not, the hotline call will fail.

The system coordinator uses *Administration programming* to set up the hotline telephone, the telephone number it dials, and the line on which that number is dialed.

Bypassing a Hotline

Press a line button, or use the *Pre-Dial* or *Automatic Dial* feature before you pick up the receiver or press  on a hotline telephone. See the section on *Customizing your telephone* for more information on *Pre-Dial* and *Automatic Dial*.

Displays

Line in use	The line assigned to the Hotline is in use. Make the call using normal methods or wait until the Hotline line is free.
No free lines	The Hotline has been set up to dial an external number on a prime line but the hotline telephone has an internal prime line and no access to line pools. Either the line pool assigned to the telephone is busy, or the telephone does not have access to a line pool. This must be corrected in Configuration and Administration programming.
No line selected	The Hotline has been set up to dial an external number on a prime line but the hotline telephone does not have a prime line. This must be corrected in Configuration or Administration programming.

Prime telephone

Each line in a Norstar system can be assigned a prime telephone. Calls not answered at their normal destinations are transferred to the prime telephone. The prime telephone is usually the receptionist's telephone. The installer or customer service representative programs a prime telephone for a line.

See the section on Answering the telephone for the displays that may occur at a prime telephone.

System features

The following features are available for the entire Norstar system.

Accidental Disconnect Protection

If you accidentally drop the receiver back into the telephone cradle while answering a call, you can quickly retrieve the call.

1. Pick up the receiver again or press . You are reconnected to your call.

Automatic Telephone Relocation

If Automatic telephone relocation is enabled in programming by your installer or customer service representative, you can move your telephone from one Norstar jack to another without it losing any of its custom programming.

Class of Service

You can use the Class of Service feature to change the dialing filters that normally apply to a specific telephone and its lines. Each person in the Norstar system can be assigned a different Class of Service password by the system coordinator.

When you enter a Class of Service password at a telephone or on a line, you override the filters that normally apply, with the filters assigned to your Class of Service password. See the Telephone features chapter for instructions.

See Using Norstar remotely in this chapter for information on Class of Service and using Norstar from outside your office.

Disconnect supervision

When Disconnect Supervision is assigned to a line, the Norstar system monitors it to detect if an external caller hangs up. This allows the system to release the line for other uses. Your installer or customer service representative assigns disconnect supervision to loop start lines. E&M and DID trunks are always supervised.

Hung lines

A line that has been redirected using Line Redirection may remain busy after a call is over. If this happens, the outgoing line for the redirection will also remain busy. These are hung lines and you must clear them.

The only real indication of a hung line is a line indicator that has been solid for a long time. However, the solid line indicator may also indicate a genuine call in progress. Make reasonably sure that the line is indeed hung before clearing it or you may cut off a real conversation.

You can clear a hung line only at the telephone that was used to redirect the line.

1. Press * at the telephone that was used to redirect the line.
2. Press the button of the redirected line.
3. Press or SHOW.
4. Press or DROP. The hung line is cleared.

Clearing the redirected line clears the outgoing line for the redirection as well.

Internal numbers

Each telephone in the Norstar system has its own internal number. The length of internal numbers in your system may be from 2 to 7 digits for a *non-expanded system*, or 3 to 7 digits for an *expanded system*. All numbers in your system are the same length. Your installer or customer service representative sets the length of internal numbers (also called the DN length).

To find out your internal number, use the *Button Inquiry* feature (*) on an intercom button. On the M7100 telephone, Button Inquiry shows your internal number followed by the function assigned to your single-memory button.

Line assignment

Any of the lines in your system may be assigned to any of your telephones. Your installer or customer service representative assigns lines to telephones in Configuration programming.

Lines can be assigned to appear only, appear and ring, or to ring only.

Usually, only the lines that are appropriate for a particular person appear at that person's telephone. When a line is assigned to a telephone it is automatically given a line button on that telephone, if a button is available. The M7100 telephone has no line buttons for its lines.

Calls on lines that ring but do not appear at a telephone are presented at an intercom button.

You may be able to answer a call on a line that does not appear or ring at your telephone. To pick up such a call, use Call Pickup, Call Park, or Trunk Answer. See the Telephone features chapter for details.

A telephone may have buttons assigned for lines 1 to 3, but have only lines 1 and 2 programmed to also ring. An incoming call on any of the three lines causes a line button indicator to flash, and the telephone can be used to answer the call. This is especially useful for people who monitor other telephone lines, but want only their own lines to actually ring.

Line pools

A line pool allows each telephone access to external lines from a group (or "pool") of external lines. You can access such lines by pressing an intercom button and entering a line pool access code or by pressing a memory button programmed with the line pool feature code and a line pool access code.

Incoming line groups

Lines can be assigned to an incoming line group to provide line concentration for incoming calls. You can then assign the incoming line group to appear at a telephone rather than each individual line. This frees up memory buttons for programming features or autodial numbers.

You can assign the same incoming line group to several telephones.

You answer calls on an incoming line group in the same way as you answer calls on a line.

Overflow call routing

If a call comes in for a target line that is busy, Norstar routes the call to the prime telephone for that target line. If there is no prime telephone assigned to the target line or if a call cannot be directed to a target line, the call goes to the prime telephone for the external line used.

Prime line

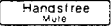
Your telephone can be programmed to select an internal or external line or a line pool automatically whenever you lift the receiver or press . This is your prime line.

Private lines

A private line is exclusive to a particular telephone. Calls that are put on hold or left unanswered on a private line cannot be picked up at any telephone except the prime telephone.

System Speed Dial

Speed dial codes 01 to 70 are the same for the entire system. See Speed Dial in the Programming chapter for details.

Target line

A target line is used to route a call directly to a particular telephone or group of telephones. Target lines are only used for incoming calls on E&M or DID lines. A single E&M or DID line may provide connections to several different target lines. This allows each person or department in the office to have their own number without having a separate external line for each number.

Set Lock

Set (telephone) Lock limits the ways in which you can customize your telephone. There are three levels of Set Lock: Full, Partial, and None.

Full Set Lock lets you change the contrast of your telephone's display, your ring type, ring volume, speaker volume, and use Button Inquiry.

Partial Set Lock allows you to forward your calls, turn on Do Not Disturb and Service Modes, and use the Background Music, Send Message, Ring Again, Privacy, and Trunk Answer features.

None (No Set Lock) allows you to access all features that are programmed for your telephone.

The system coordinator assigns Set Lock to each telephone in Administration programming.

Set Lock does not affect call handling features.

Using Norstar remotely

You can use the lines, and some of the features, of a Norstar system from outside that system. You can do this over the public telephone network when you are away from the office, or you can call from another system, over a private network.

Remote users can access Norstar lines, line pools and the Page feature. The exact facilities available to you through remote access vary depending on how your system is set up.

Examples

A sales representative who spends a great deal of time on the road needs to make long distance calls to the European office. Your Norstar system has a leased line to Europe with reduced transatlantic charges. You provide that sales representative with a Class of Service password that gives access to the transatlantic line. The sales representative can then telephone into the Norstar system from a hotel, enter their Class of Service password, and use the leased transatlantic line to make calls.

The manager of one of your branch offices also needs to talk to the European office. They use a private network line between the branch office and the head office to access the head office's Norstar system and use its transatlantic lines.

Accessing Norstar remotely over the public network

You can use Norstar remotely over the public telephone network.

1. Dial the Norstar system's remote access number.
2. If you hear a stuttered dial tone, enter a COS password.
3. Wait for the system dial tone.

Accessing Norstar over a private network

You can access Norstar remotely using a private network line.

1. Select the private network line or the line pool that contains private network lines.
2. Dial the remote access number, if needed.
3. If you hear a stuttered dial tone, enter a COS password.
4. Wait for system dial tone.

Using Norstar remotely

Once connected to a remote Norstar system you can do any one of the following:

- Enter the DISA internal number followed by a COS password to change your Class of Service.
- Dial the number of someone on the remote Norstar system.
- Dial a line pool access code and make an external call.
- Dial a Destination code.
- Enter a Page feature code (60 through 63). Use instead of when entering the feature codes. See Page in the Telephone features chapter.

Tones

You may hear some of the following tones while accessing Norstar remotely.

Busy tone

You have done one of the following:

- Dialed a busy number on the Norstar system. Your call will be disconnected after five seconds.
- Dialed a busy line pool access code. You will hear system dial tone again after 5 seconds.

Norstar system dial tone

You may:

- Enter the DISA internal number followed by a COS password to change your Class of Service.
- Dial the number of someone on the remote Norstar system.
- Dial a line pool access code and make an external call.
- Dial a Destination code.
- Enter a Page feature code (60 through 63) using instead of .

Fast busy tone

You have done one of the following:

- Entered an incorrect COS password. Your call will be disconnected after five seconds.
- Taken too long while entering a COS password. Your call will be disconnected after five seconds.
- Tried to use a line pool or feature not permitted by your Class of Service. You will hear system dial tone again after five seconds.
- Dialed a number in the Norstar system which does not exist. Your call will be disconnected after five seconds.

Stuttered dial tone

Enter your COS password.

Controlling access to your Norstar system

It is important that you maintain the security of your Norstar system by limiting access to authorized users and limiting those users to just those features they need.



Remote users can make long distance calls

Remember that a remote user can make long distance calls that will be charged to your company and can make page announcements in your office.

Direct Inward System Access

You can control access to your Norstar system with Direct Inward System Access (DISA). If your installer or customer service representative programs the line used for remote access to automatically answer a call and wait for a DISA internal number, callers will hear a stuttered dial tone and must enter a Class of Service password before they are allowed into the system. Access to your Norstar system from the public telephone network should always be controlled with DISA.

If you are setting up access to your system from another Norstar system over a private network, you may not need DISA. If your installer or customer service representative programs your E&M line to automatically answer a call (without DISA,) callers from remote Norstar systems will receive system dial tone immediately. Callers can still dial the DISA internal number and enter a Class of Service password at this point.

Class of Service

To control which feature a remote user can access, you can assign a remote filter and remote package to the line used for remote access. The remote filter restricts the numbers that can be dialed on the line; the remote package restricts the use of line pools and the Page feature. To change the restrictions for the line, the user can enter their Class of Service password when the system answers with DISA or can dial the DISA internal number and enter their Class of Service password.

Maintaining security

To maintain the security of your system, the following practices are recommended:

- Warn anyone to whom you give the remote access number to keep it confidential.
- Change Class of Service passwords often.
- Warn anyone to whom you give a Class of Service password to remember it and not to write it down.
- Remove the Class of Service password of anyone who leaves your company.

Tips

To use the system remotely, you must use a telephone with tone dialing to call the system.

Remote access is possible only on DID lines, and E&M and loop start lines that your installer or customer service representative programs to auto-answer calls.

If the loop start line used for remote access is not supervised, auto-answer will not function and the caller will hear ringing instead of a stuttered tone or the system dial tone.

To use features on a remote Norstar system, press * followed by the feature code. Even if you are calling from a Norstar system, press * instead of .

In certain situations, you may experience lower volume levels when using Norstar remotely.

Telephone features

To use a Norstar feature, enter the feature code and watch your telephone display for instructions. Different displays come up at different times, depending on how you invoke the feature and on the choices you make while using the feature. If you want more information about a display, look it up in the Displays section of each feature listing.

The displays shown in this book use a three-digit internal number, which is the default for an expanded system. (A non-expanded system has a 2-digit internal number default.)

One-line and two-line displays

All Norstar telephones have displays that give you information about your calls and guide you through Norstar features. The M7100 and M7208 telephones have a one-line display. The M7310 and M7324 telephones have a two-line display.

The second line of a two-line display shows the functions of the three buttons directly below it. If you have a telephone with a two-line display, you can use these display buttons.

Some display buttons, such as TRANSFER and ALL, are simply shortcuts. If you have a telephone with a one-line display, these shortcuts are not available.

Other display buttons, such as OK and SHOW, perform essential functions. If your telephone has a one-line display, you can use the following buttons instead of these display buttons:

<u>OK</u>	Hold	<u>CANCEL</u>	#
<u>QUIT</u>	Rts	<u>VIEW</u>	#
<u>ADD</u>	*	<u>OUERRIDE</u>	#
<u>SHOW</u>	#	<u>BKSP</u>	◀▶

All displays listed in this book are shown as they appear on the two-line display. If you are using a telephone with a one-line display, ignore both the second line of the display shown in this book, and the instructions for using display buttons.

Common feature displays

You may see the following displays when you use a feature.

Access denied	Someone is using Configuration or Administration programming. You cannot use programming features. Try again later.
Denied in admin	You have tried to use a feature, but you have not been given access to it in Administration programming. See your system coordinator.
Feature timeout	You have taken more than 15 seconds to press a button in response to a display.
Inactive feature	You have entered a feature code that is used by an application program that your system does not have.
Invalid code	You have entered an invalid feature code.
Not available	You have tried to use a feature that is not available in the present setup of your Norstar system.
Set locked	You cannot use the feature you have chosen because your telephone is locked in Administration programming. See Set lock in the Programming chapter.

One button access

You can program most Norstar feature codes onto telephone memory buttons so that you can use the feature by pressing a single button. Whenever the instructions tell you to enter a feature code, you can do so by pressing a memory button programmed with the feature code. See the procedures in the Feature programming section.

Canceling a feature

Some features change the way your telephone works. To make your telephone work normally again, you must cancel the feature. To cancel a feature, press , then and the feature code. For example, to cancel Call Forward () , press .

If a feature code is programmed onto a memory button, you may be able to cancel the feature by pressing the memory button again, while the feature is active.

If you change your mind in the middle of using a feature, you can back out by pressing or . Be aware that pressing disconnects any active call.

M7100 telephone

Because the M7100 telephone does not have any line buttons it sometimes works slightly differently from other Norstar telephones. Where other telephones may require you to select a line button to answer a call, on the M7100 telephone you simply pick up the receiver. Where other telephones require you to select a line button to take a call off hold, you press on the M7100 telephone. The M7100 telephone cannot have a button. You will find special instructions for the M7100 telephone in the Tips section of some feature descriptions.

What you can do with the features

The telephone features help you with your daily business communications. You can use a variety of features to accomplish a task. For detailed information on how to use a particular feature go to the corresponding section in this chapter.

Answer a call

- Call Information
- Call Pickup
- Conference
- Group Listening
- Handsfree/Mute
- Privacy

Change your telephone defaults

- Button Inquiry
- Contrast Adjustment
- Class of Service
- Dialing modes
- Do Not Disturb
- Feature programming
- Language choice
- Moving line buttons
- Privacy
- Ring type
- Ring volume

Check the length of a call

- Call Duration Timer
- Time

Communicate within your office

- Page
- Priority call
- Ring Again
- Voice call

Handle many calls at once

- Call Queuing
- Hold

Have your calls answered at another telephone

- Call Forward
- Line Redirection
- Service Modes

Log your incoming calls

- Call Log

Make calls quickly without having to dial the whole number

- Autodial
- Last Number Redial
- Messages
- Speed Dial
- Saved Number Redial

Make calls to numbers outside your Norstar system

- Dialing
- Host system signaling
- Line pools
- Transfer

Autodial

You can program memory buttons for one-touch dialing of internal or external telephone numbers.

Programming an external autodial button

1. Press * .
2. Select the button you want to program. This is not necessary for the M7100 telephone.
3. If you want to include a line selection for this number, press the line or intercom button. To select a line pool, press a programmed line pool button, or press and enter a line pool access code. For the M7100 telephone, you can select a line only.
4. Enter the number.
5. Press or **OK**.

Programming an internal autodial button

1. Press * .
2. Select the button you want to program. This is not necessary for the M7100 telephone.
3. Enter the number.

Displays

987_
QUIT BKSP OK

Continue to enter digits until the number is complete. Press or **BKSP** to erase an incorrect digit. Press or **OK** when you are finished.

Access denied

Someone is programming the system. Wait 5 minutes and try again.

Autodial full

The memory allotted to autodial numbers in your Norstar system is full.

Button erased

While programming External Autodial, you pressed or **OK** before entering any digits. This erases the button.

Enter digits QUIT OK	Enter the number you wish to program exactly as you would if you were dialing it yourself.
Hidden number	The last number you dialed was hidden.
Hold or release	You cannot program an autodial button while you are on a call. Finish your call or place it on hold before programming an autodial button.
Incoming only	You have selected a target line or an incoming line group. These lines are used for incoming calls only. Choose another line.
Intercom #: _ QUIT	Enter the internal telephone number you wish to program.
Invalid number	You are programming an internal autodial button, and have entered a number that is not an internal number on your system. Enter a valid internal number. If the number you are entering is a destination code, use external autodial.
Press a button QUIT	Press the memory button you want to program.
Program and HOLD	Enter the number you want to program onto the button, then press <input type="text" value="Hold"/> .
Program and OK QUIT OK	Enter the number you want to program onto the button, then press <input type="text" value="Hold"/> or OK . You may include a line or line pool selection in an autodial sequence by selecting the line before entering any digits.
Programmed	The number is stored on the button.

Tips

If the power to your Norstar system is off for more than three days, autodial numbers may be lost from the memory.

Autodial numbers must be programmed onto memory buttons. They can not be programmed onto line, incoming line group, answer or Handsfree/Mute buttons.

You can program host system signaling codes as part of a number on an external autodial button. See *Host system signaling*.

If you do not include a line selection in an autodial number, the call will use your prime line, if you have one. If you select a line before pressing the autodial button, any line selection programmed onto the autodial button is ignored.

When programming an autodial number to use a line pool, use and the line pool access code, or a programmed line pool button.

To program a destination code on an autodial button, use external autodial, press to specify the line you want to use, then enter the destination code as the number to dial.

You can copy the telephone number from a Last Number Redial button or Saved Number Redial button onto an autodial button. *Simply enter the Last Number Redial feature code or Saved Number Redial feature code when the Autodial feature asks you to enter a number.*

You cannot program an autodial button using Last Number Redial if the last number dialed was a speed dial number that was programmed to display a name and not the number.

If you press as the line for an external autodial number, you must include a valid line pool access code or a destination code. *If line pool access codes or destination codes are changed, autodial numbers based on them will no longer function correctly.*

Background Music

Feature 8 6

Listening to music

You can listen to music through your telephone speaker.

1. Press Feature 8 6.

The music stops automatically if you make or answer a call.

Your installer or service representative makes this feature available to all telephones in Configuration programming. You will need to supply a music source, such as a radio, attached to your KSU.

! License needed for radio or TV broadcasts

In accordance with U.S. copyright law, a license may be required from the American Society of Composers, Authors and Publishers or a similar organization if radio or TV broadcasts are transmitted through the Background Music feature of this telecommunication system.

Northern Telecom Inc. hereby disclaims any liability arising out of the failure to obtain such a license.

Canceling Background Music

Feature # 8 6

You can stop the background music.

1. Press Feature # 8 6.

Displays

Music OFF The Background Music feature is off.

Music ON The Background Music feature is on.

Button Inquiry

 * 0

You can check the function of any line, intercom, or programmed button on your Norstar telephone.

1. Press * 0.
2. For all telephones other than the M7100 telephone, press the button you want to know about.
3. Read the display.

Displays

001 <LINENAME>
SHOW OK

You have used Button Inquiry on a line button. The display shows the number and name of the line. Press **SHOW** to view the redirection status of the line.

123456789012345...
VIEW→ OK

Press or press **VIEW→** or **←VIEW** to view a number that is too long to fit on the display. Press or **OK** when you are done.

221 <SETNAME>
NEXT VIEW→

You have used Button Inquiry on an intercom button. The display shows the directory number of the telephone, and the assigned name. Press **NEXT** to see the first line assigned to ring at the intercom button.

<Feature name>
SHOW OK

The name of the feature assigned to a button is displayed when you press the button. **SHOW** appears when there is more information available. Press or **SHOW** for additional information.

Press a button
EXIT

Press the button you want to check. Press or **EXIT** when you are finished.

Release calls

You have tried to use Button Inquiry while you were on a call or had calls on hold.

Tips

On the M7100 telephone, Button Inquiry shows your internal number followed by the function assigned to your single memory button.

When you are labeling or replacing a button cap, use Button Inquiry so that you won't accidentally activate a feature.

Call Duration Timer

Feature

You can see how long you spent on your last call or how long you have been on your present call.

1. Press .
2. Read the display.

Displays

221 02:47

The display shows the last call you made, or the current call, and the total elapsed time in minutes and seconds.

Line001 01:45

You parked your last call. The display shows the length of time the call was parked.

Make call first

You have not made a call since your telephone's clock was last reset.

Call Forward

Feature 4

Forwarding your calls

You can have all your calls forwarded to another telephone in the Norstar system.

1. Press Feature 4 .
2. Enter the number of the internal telephone that you want your calls forwarded to.

Forwarding remains in effect until you enter the Cancel Call Forward feature code.

Canceling Call Forward

Feature # 4

You can start to receive your calls again.

1. Press Feature # 4 .

Call Forward on Busy

Call Forward on Busy redirects calls to another telephone when you are busy with a call. The system coordinator sets up Call Forward on Busy in Administration programming.

Call Forward (No Answer)

Call Forward (No Answer) forwards unanswered calls to another telephone. The system coordinator sets up Call Forward (No Answer) in Administration programming.

Overriding Call Forward

You can call someone who has their calls forwarded to you.

1. Dial that person's number. Your call rings at that person's telephone even though they are forwarding their calls to you.

Displays

Forward denied

You cannot forward calls to the number you have chosen. There are several reasons why this can happen. For instance, you cannot forward your calls to a telephone that has been forwarded to your telephone.

Forward to:

Dial the internal number of the telephone that you want your calls to be forwarded to.

Forward>221 CANCEL	Your calls are being forwarded to telephone 221. Press Feature <input type="text"/> # <input type="text"/> 4 or CANCEL when you want to stop forwarding your calls.
Not in service	Two or more telephones are linked in a forwarding chain, and one of them is out of service or is being used for programming.

Tips

When a call is forwarded, it does not ring but its line indicator still flashes on your telephone. You can answer the call by pressing the button next to the flashing indicator.

If the telephone to which you forwarded your calls does not have the same external lines as your telephone, the forwarded calls appear on intercom buttons.

Telephones that have Call Forward on Busy active can still receive priority calls.

Call Forward on Busy does not forward camped calls.

When Call Forward is active, all calls go to the call forward destination, regardless of the Call Forward on Busy and Call Forward no Answer settings.

You can use the Do Not Disturb feature to forward your calls to the prime telephone.

Note the differences between Line Redirection and Call Forward. Call Forward forwards all calls that arrive at a particular telephone to another telephone within the Norstar system. Line redirection redirects only the lines you specify, no matter which telephones they appear on, to a telephone outside the Norstar system.

If you are one of a group of people who regularly forward their calls to one another, be aware that it is possible to set up forward loops where a call is forwarded from one telephone to another in a circle, and is never answered anywhere.

Calls that are redirected by Line Redirection are not affected by any of the Call Forward features.

Call Information

Feature 8 1 1

Call Information lets you display information about incoming calls. This information is more detailed than the Call Display information you automatically receive. See Answering the telephone in this chapter for details. For external calls, you can display the caller's name, telephone number, and the line name. For an internal call, you can display the caller's name and their internal number. You can obtain information from ringing, answered, or held calls.

Names and numbers for external calls are displayed only if you have subscribed to Call Display services from your telephone company.

Displaying Call Information before or after answering

To find out who is calling or to display information about your current call:

1. Press **Feature** **8** **1** **1**. For an internal call, the caller's name and the internal number are displayed.

For an external call, Call Display information is displayed according to how this feature is programmed in Administration programming.

2. Press **#** or **VIEW** to display more information about an external call.

Displaying Call Information for a call on hold

To obtain information about your held call:

1. Press **Feature** **8** **1** **1**. The display reads ► **Select a call**.
2. Select the line on hold. If the call is an internal call, the caller's name and internal number are displayed. If the call is an external call, the caller's information is displayed.
3. Press **#** or **VIEW** to display more information about an external call.

Displays

▶5551 234
EXIT VIEW

You are on an active call with a caller at 555-1234.

▶5551 234
EXIT VIEW

You are on an active long distance call with a caller at 555-1234.

Tips

Call Display information becomes available between the first and second ring of an alerting call. If you answer before the Call Display information is available on your display, and you press

Feature 8 1 1, you will only see the line number or line name.

Call Log displays the same information as Call Information, along with the date and time of the call, and the number of times the caller called.

If your telephone automatically displays Call Display information for a call, you still need to press Feature 8 1 1 before you can press # or VIEW to display more information about the call.

Call information is available for calls even if they have been transferred, forwarded or rerouted in some way.

Call Log

Call Log creates a list of records of incoming external calls. The log could contain the following information for each call:

- sequence number in the Call Log
- name and number of the caller
- indication if the call was long distance
- indication if the call was answered (and identification of who answered it)
- time and date of the call
- number of repeated calls from the same source
- name of the line that the call came in on

Call Log can help you to:

- keep track of abandoned or unanswered calls
- track patterns for your callers (for example volume of calls and geographical location of calls)
- record caller information quickly and accurately
- build a personal telephone directory from log items

Log space is assigned to each telephone. Since a log can become full, Call Log has an Autobump feature that can automatically delete an old log item when a new call is logged.

Names and numbers for external callers are displayed only if you have subscribed to Call Display services from your local telephone company.

Call Log options

Feature * 8 4

You can select the type of calls that will be stored in your Call Log.

1. Press * 8 4 . The display shows the current option.
2. Press # or **NEXT** to change the option.
3. Press or **OK** to select the display option.

Logging a call manually

Feature 8 1 3

If your calls are not automatically logged, Logit lets you manually log call information when you are connected to an external call. Being able to store information for your current call can be helpful in many situations. For example, you may want to:

- record a caller's information without using paper and pencil
- record only selected calls that you personally choose, as opposed to using Call Log automatically
- quickly record caller information before a caller hangs up

To manually log an external call:

1. Press Feature 8 1 3 .

Deleting old Log items

Feature 8 1 5

Your log has a set number of items that it can hold. When it becomes full, new calls cannot be logged. When your log is full, Autobumping automatically deletes your oldest call log item when a new call is logged.

To enable autobumping:

1. Press Feature 8 1 5 .

To disable autobumping:

1. Press Feature # 8 1 5 .

Viewing your Call Log



Feature 8 1 2

You can view the information stored in your Call Log. To view your log:

1. Press Feature 8 1 2 . The display shows the number of previously read items (Old) and the number of new, unread items (New) in the log.
2. Press * or OLD to view old items; press # or NEW to view new items.
3. Press 0 or RESUME to display the last item you viewed, the last time you viewed your Call Log.



Viewing a Call Log item

To view the information for a call log item:

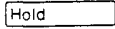

1. Press   or **MORE**.

Erasing Log items

You should routinely erase log items that you've read, to make space for new items in your log.

1. Display the item you want to erase.
2. Press  or **ERASE**.
3. Press  to exit.



If you accidentally erase an item, you can retrieve it.

1. Press  or **UNDO** immediately after accidentally erasing an item.
2. Press  to exit.

Calling from Call Log

You may find it helpful to place calls from within your Call Log. The number stored for each call may vary depending on the type of call. For example, if the call was placed from a Centrex or PBX system, the first few numbers may need to be "trimmed" before you can make the call. If the number that you want to call is long distance or if you want to use a line pool, you may need to add numbers.

To place a call:

1. Display the log item for the call you want to place.
2. Display the associated telephone number.
3. Press   or **TRIM**, once for every digit that you want to remove.
4. Dial any extra digits required.
5. Press an external line or line pool button.
6. Lift the receiver. (This is not necessary if Handsfree is programmed at your telephone.) The displayed number is dialed.

Call Log password

You have the option of accessing your Call Log through a password. If you forget your password, there is a facility in Administration programming to clear it. You can then enter a new password from your telephone.

To assign a password to your Call Log:

1. Press * 8 5 . The display reads **New Password:**.
2. Enter your four-digit password. The display reads **Repeat New:**.
3. Re-enter your four-digit password. The display reads **Password changed**, which confirms that your password has been assigned.

To change your Call Log password:

1. Press * 8 5 . The display reads **Old Password:**.
2. Enter your old password. The display reads **New Password:**.
3. Enter your new four-digit password. The display reads **Repeat New:**.
4. Re-enter your password. The display reads **Password changed**, which confirms that your password has been changed.

After assigning a password to your Call Log, you may later decide that you do not want to use a password at all. To delete an assigned password:

1. Press * 8 5 . The display reads **Old Password:**.
2. Enter your old password. The display reads **New Password:**.
3. Press or **OK**. The display reads **No Pswd assigned**, which confirms that your password has been deleted.

To enter Call Log using your password:

1. Press 8 1 2 to enter Call Log. If you have programmed a password, the display reads **Password:**.
2. Enter your four-digit password.

Displays

1:Unknown call	The caller's name and number are unknown.
1:Unknown name	The caller's name is unavailable.
1:Unknown number	The caller's number is unavailable.
12:KATE SMITH NEXT ERASE MORE	_ indicates a new item.
12)KATE SMITH NEXT ERASE MORE) indicates that the call was answered.
12\$KATE SMITH NEXT ERASE MORE	\$ indicates a long distance call.
49/1234567890123 NEXT ERASE MORE	/ indicates that there is more information for a call. Press [Left Arrow] or MORE to display the remaining information.
Autobumping OFF	The Autobumping feature is disabled.
Autobumping ON	The Autobumping feature is enabled.
Call for you	There is one new item in the Call Log.
Call logged	The call was successfully logged with Logit.
Call(s) bumped	One or more log entries have been deleted by the Autobumping feature.
Calls for you	There are two or more new items in the Call Log.
Hold or release	Hold or release your active call before entering Call Log.
In use: SETNAME	The external line is in use.
Item erased	The item was erased from the Call Log.
Jan 4 9:00a 3X NEXT ERASE MORE	The repeat call counter, shown along with time and date, indicates the number of calls you have received from the same caller.

Line001 J227 NEXT ERASE MORE	This call was answered at another telephone (227).
Line001 JLogit NEXT ERASE MORE	This call was manually logged.
Line001 NEXT ERASE MORE	This call was not answered.
Log is empty	Your Call Log is empty.
Log is full	Your log is full. No additional calls can be logged until you either turn Autobumping on, or delete some items in your log.
Messages & Calls MSG CALLS	There are one or more items in your message waiting list, and there are one or more new items in your Call Log.
New calls begin	You have viewed your last old item and will now view your new log items.
No free lines	All lines in the pool are in use.
No info to log	No information is available for the call.
No log assigned	No log space has been assigned to the telephone.
No new items	There are no new calls in the Call Log.
No old items	There are no old or viewed items in the Call Log.
No resume item	The resume item is no longer in the Call Log due to Autobumping, repeat call update, or log reallocation.
Private name	The caller's name is private.
Private number	The caller's number is private.
Release calls	Release your active call before entering Call Log.

Tips

You may want to use the overlay, that is provided in the *Call Log Feature Card*. This card is available in a separately orderable Call Display Button Cap Kit. Contact your service representative for information.

The long distance indicator, as well as the caller's name and number, may not be shown in the log, depending on the Call Display services provided by your local telephone company.

For tips on programming Call Logs, see the Call Display services section.

Call Information displays but does not store the same information as Call Log.

Call Park

 Feature 7 4

Parking a call

You can suspend a call so that it can be retrieved from any telephone in your system.

1. Press Feature 7 4 .
2. Use the Page feature to announce the retrieval code displayed by your telephone.

Retrieving a parked call

1. Select an internal line. (On the M7100 telephone, pick up the receiver.)
2. Dial the Call Park retrieval code.

Displays

Already parked	The person you were talking to has already parked your call. You cannot park the same call.
Get call first	You have attempted to use Call Park with no active call on your telephone. If the call you wish to park is on hold, reconnect to it before you park it.
Invalid number	You have entered an invalid retrieval code.
No call on: 101	There was no call on the retrieval code you entered.
No call to park	You have attempted to park a call, but there are no calls at your telephone.
Park denied	You have tried to park a conference call. Split the conference and park the calls separately. The person who retrieves the calls can reconnect the conference.
Parked on: 402 PAGE EXIT	Record the code shown. Use Page (<input type="text"/> Feature <input type="text"/> 6 <input type="text"/> 0) or press PAGE to announce the call and its retrieval code.
Parking full	All available retrieval codes are in use. Transfer the call or take a message instead.

Tips

When you park a call, the system assigns one of nine codes for the retrieval of the call. These codes consist of the *Call Park* prefix, which may be any digit from 0 to 9, and a two digit call number between 01 and 09. For example, if the *Call Park* prefix is 4, the first parked call is assigned *Call Park* retrieval code 401.

Your installer or customer service representative sets the *Call Park* prefix.

Your installer or service representative also sets the *Call Park* Callback delay in Configuration programming. External calls parked for longer than the program delay are returned to your telephone.

Call Park can be disabled by your installer or customer service representative.

Call Pickup

You can pick up a call that is ringing at another telephone.

Directed Pickup

Feature 7 6

You can answer any telephone that is ringing in your Norstar system.

1. Press Feature 7 6.
2. Enter the internal number of the ringing telephone.

Group Pickup

Feature 7 5

Your Norstar system can be divided into as many as nine Pickup groups. If you are a member of a pickup group, you can pick up a call that is ringing at any telephone in your pickup group.

1. Press Feature 7 5.

Displays

Already joined

You are already connected to the telephone that made the call you are trying to pick up. This can happen if you are on a call to a co-worker, your co-worker dials the number of a telephone in your pickup group, and you attempt to pick up that call.

Denied in admin

Your telephone is not a member of a Pickup group.

No button free

You have tried to pick up a call when you have no line button available.

Pickup denied

There is no call that you can pick up or the call that was ringing has already been answered.

You have tried to pick up a call on someone else's private line.

Pickup:

Enter the internal number of the telephone that is ringing. (You may use an internal autodial button to do this.)

If you decide not to answer a ringing call after you have activated Directed Pickup, press .

Tips

Call Pickup cannot be used on private lines. Group Pickup cannot be used to retrieve a camped call.

To use Directed Pickup, the telephone must be ringing. If, for example, the auxiliary ringer is ringing, but the call is not ringing at a telephone, the call cannot be answered using Directed Pickup. It must be answered normally at a telephone that has a flashing indicator for the call, or by using Trunk Answer.

If a call is ringing on an answer button, you can use Directed Pickup to answer the call by entering the internal number of any member of the answer group.

If there is more than one incoming call at a telephone in a pickup group, a call ringing on the prime line is answered first followed by calls on external lines and, finally, calls on internal lines.

You can assign telephones to one of nine Pickup groups in Administration programming.

Call Queuing

Feature

When you have more than one call ringing at your telephone, you can choose the call that has the highest priority.

1. Press .

Displays

No call waiting

There are no calls waiting to be answered

Pick up receiver

You have answered a call, using Call Queuing, but you do not have Handsfree assigned to your telephone. Pick up the receiver to speak with the caller.

Tips

Call Queuing answers incoming external calls before callback, camped, and transferred calls.

Camp-on

Feature 8 2

Camp a call

You can transfer an external call to another telephone, even if all its lines are busy.

1. Press Feature 8 2.
2. Dial the number of the telephone you want to camp the call to.

Displays

221 Camp max CALLBACK	You tried to camp a call to a telephone that already has a camped call. The call has come back to you. Press the CALLBACK button or the line button to reconnect to the call. On the M7100 telephone, just pick up the receiver.
221 DND CALLBACK	The person to whom you redirected a call has Do Not Disturb active on the telephone. The call has come back to you. Press the CALLBACK button or the line button to reconnect to the call. On the M7100 telephone, just pick up the receiver.
Camp denied	You have tried to camp an internal call. You can only camp external calls.
Camp to: CANCEL	Dial the number of the internal telephone to which the call will be sent.
Camped: 221 CALLBACK	The telephone to which you camped a call did not answer the call. The call has come back to you. Press CALLBACK or the line button to reconnect to the call. On the M7100 telephone, just pick up the receiver.
Line001 hung up	A call you camped has come back to you, but the caller hung up before you could reconnect.
Make call first	You have no call to camp. If the call you want to camp is on hold, take it off hold and then camp it.

Not in service CALLBACK	The telephone to which you have camped a call is out of service or is being used for Configuration or Administration programming. The call has come back to you. Press CALLBACK or the line button to reconnect to the call. On the M7100 telephone, just pick up the receiver.
Release a call	The line that the camped call is on is in use or that line does not appear at your telephone. Release the line or release an internal line.

Tips

Camp-on is a form of transfer.

Camped calls appear on a line button on the receiving telephone, if one is available. If there is no line button available, you receive a message on the display and hear Camp tones.

Conference

Feature

Creating a conference

You can talk to two people at once.

1. Make sure you have two calls, one active and one on hold.
2. Press .
3. Take the held call off hold (this is automatic on the M7100 telephone).

Disconnecting one party

You can disconnect one party from a conference and continue talking to the other.

On an M7208, M7310 or M7324 telephone:

1. Press the line button of the call that you want to disconnect. The call that you want to keep is automatically put on hold.
2. Press . The call is disconnected.
3. Press the line button of the held call to speak to the remaining person.

On an M7100 telephone:

1. Press , to place one caller on hold. Press again if necessary, to put the caller you want to keep on hold.
2. Press . The call is disconnected.
3. Press to speak to the remaining party.

Independently holding two calls

For all Norstar telephones except the M7100 telephone, you can put the two people on hold independently so that they cannot talk to each other.

1. Press the line button of one person. The other person is automatically put on hold.
2. Press . The second person is put on hold.

You can re-establish the conference.

1. Take one call off hold.
2. Press .
3. Take the other call off hold.

Putting a conference on hold

You can put a conference on hold, allowing the other two people to continue speaking to each other.

1. Press .

You can reconnect to the conference.

1. Press either of the held line buttons (for the M7100 telephone, press). You are reconnected.

Splitting a conference

You can talk with one person while the other person is on hold.

On an M7208, M7310 or M7324 telephone:

1. Press the line button of the person you want to speak to. The other person is automatically put on hold.

On an M7100 telephone:

1. Press . The first party is on hold.
2. Press , if necessary, to switch parties.

You can reestablish the conference.

1. Press .
2. Take the held call off hold. This is not necessary for the M7100 telephone.

Removing yourself from a conference

You can remove yourself from a conference, and connect the other two callers through your Norstar system.

1. Enter the Transfer feature code .

Displays

3 Parties only	You are trying to add a fourth party to your conference call, or to join two conferences together. Release one call from the conference before adding another, or keep the two conferences separate.
Access denied	Privacy control cannot be used on internal or conference calls.
Conf. on hold	You have put a conference call on hold.
Conference busy	You have tried to make a conference call, but your system is already handling its maximum number of conference calls.
Line001 221 TRANSFER	You are on a conference with the two lines or telephones shown. You can drop out of the conference and leave the other two parties connected (Unsupervised Conference) by pressing TRANSFER or entering the Transfer feature code.
Make calls first	You have tried to set up a conference call, without having made the calls that are to be connected. Make both calls first.
Make second call	You have tried to set up a conference call while connected to only one caller. Put your first call on hold, make a second call, and enter the Conference feature code again.
No free lines	You have put a conference call on hold from your M7100 telephone, then tried to get another line. Your M7100 telephone can handle only two lines at a time, and your conference call is using both of them.
Press held line	You have activated the Conference feature with one call active and another on hold. Press the line of the call on hold to bring that person into the conference.

Tips

Only the person who established the conference can process the conference in any of the ways just described.

You can have a maximum of three people in a Conference.

When you remove yourself from a conference using the Transfer feature, and both callers are from outside your system, one of the callers must have called you on a disconnect supervised line, or the call will be disconnected.

If you are using an M7100 telephone:

- Your conference is connected as soon as you enter the Conference feature code. There is no need to take the second call off hold.
- You cannot independently hold two calls.
- You cannot join an existing two-party call to establish a Privacy conference although you can use the Privacy feature for calls at your telephone.

You can also create a conference by releasing privacy on a call. See the Privacy feature for details.

When a third person joins a conversation on a line that has privacy turned off, the call becomes a conference. All the rules applicable to a conference apply except that there is only one line in use, instead of the normal two. This means that you cannot split a conference set up using Privacy.

In certain situations, you may experience lower volume levels when using the Conference feature with two external calls.

COS password

Feature 6 8

Changing your Class of Service

Norstar uses dialing filters, setup by the system coordinator, to restrict the numbers you can dial on a line or from a telephone. When you enter your Class of Service (COS) password at a telephone, the dialing filters associated with your Class of Service password apply, rather than the normal dialing filters.

To change the dialing filters on a line or telephone:

1. Press Feature 6 8 .
2. Enter your six-digit COS password.

Displays

(Blank display) Enter your password. It will not be shown on the display.

Invalid Password You have entered a password that is not programmed into your system.

Tips

If you use your Norstar system from outside the office, you may have to enter a Class of Service password to gain access to the system. See Using Norstar remotely.

You must enter a Class of Service password each time you wish to make a call that is normally restricted on a line or telephone.

Norstar allows up to 100 Class of Service passwords.

The system coordinator defines Class of Service passwords and dialing filters in Administration programming.

Contrast adjustment

 *

You can set the contrast level of your telephone display.

1. Press * .
2. Choose the contrast level you like best. The number of contrast levels available varies from one Norstar telephone to another.

Displays

Contrast level 2
DOWN UP OK

Press a number on the dial pad, or UP or DOWN for the contrast level you want. Press or OK to set the new contrast level.

Dialing modes

Feature * 8 2

Your Norstar telephone has three dialing modes: Automatic Dial, Pre-Dial, and Standard Dial. All three modes support on-hook dialing. (On-hook dialing means dialing a call without picking up the receiver.) The special features of the Automatic and Pre-Dial modes are available only when you dial on-hook.

Standard Dial lets you make a call by selecting a line and dialing the number. If you have a prime line, it is selected automatically when you lift the receiver or press Handsfree .

Automatic Dial lets you dial a number without selecting a line. Your prime line is selected as soon as you start dialing a number. Automatic Dial does not work if your telephone has no prime line or if your prime line is in use.

Pre-Dial lets you enter a telephone number, check it, then change it before actually making the call. The call is not dialed until you select a line or line pool, or pick up the receiver. You can pre-dial both external and internal numbers. You must, however, select the correct type of line (external or internal) for the type of number you have entered.

Choosing a dialing mode

You can set the dialing mode of your telephone.

1. Press Feature * 8 2.
2. Choose the dialing mode you want.

Displays

Standard dial
NEXT OK

The current dialing mode is shown. Press # or NEXT until the dialing mode you want appears. Press Hold or OK to select the displayed dialing mode.

Tips

The Dialing Modes feature code cannot be programmed onto a memory button.

Standard Dial does not support on-hook dialing on an M7100 telephone. If you have an M7100 telephone, use the Automatic Dial or Pre-Dial feature for on-hook dialing.

Telephones connected to an Analog Terminal Adapter (ATA) cannot use Automatic Dialing.

Automatic Dial is only available if a telephone has a prime line assigned.

If your telephone starts ringing while you are pre-dialing a number, you can stop the ringing by turning on Do Not Disturb (Feature). This does not affect numbers you are entering.

You cannot pre-dial a telephone number if all the lines on your telephone are busy.

Do Not Disturb

 Feature 8 5

Stop calls

You can stop calls from ringing at your telephone.

1. Press Feature 8 5.

Only priority calls will ring at your telephone. A line button will flash when you receive a call, but the call will not ring.

Refusing to answer a call

While you are on a call, you can refuse to answer a second call (including a priority call).

1. Press Feature 8 5 while your telephone is ringing.

Canceling Do Not Disturb

 Feature # 8 5

You can cancel Do Not Disturb.

1. Press Feature # 8 5.

Displays

Allow calls

Your telephone will receive calls normally.

Do not disturb

Your telephone is in Do Not Disturb mode.
To cancel Do Not Disturb, press

 Feature # 8 5.

Tips

If you use Do Not Disturb while an external call is ringing, the call is forwarded to the prime telephone. It may also be answered by anyone whose telephone shares the line it is on. Once you turn Do Not Disturb on, calls will be forwarded to the prime telephone only if there is no other telephone on which the line appears. (The Delayed Ring Transfer feature transfers all unanswered calls to the prime telephone after a specified time.)

Do Not Disturb also prevents voice calls from alerting at your telephone. Voice calls are presented as normal intercom calls.

Group Listening

Feature 8 0 2

Listening in a group

You can let people in your office listen in on a call.

1. Press Feature 8 0 2 .

You hear the caller's voice through your telephone's speaker. Continue to speak to the caller through the telephone receiver. Your telephone's microphone is off, so the caller will not hear people in your office.

Canceling Group Listening

Feature # 8 0 2

You can cancel Group Listening for the current call.

1. Press Feature # 8 0 2 .

Group Listening is canceled automatically when you hang up.

Displays

Make call first

You have tried to use Group Listening when you are not on a call.

Pick up receiver

You have tried to use Group Listening without picking up the receiver.

Tips

Keep the receiver away from the speaker, or you may hear feedback. The higher the volume, the more the feedback. Press Rls to prevent feedback when hanging up.

You can switch a Group Listening call to handsfree by pressing Handsfree Mute . To switch back to Group Listening, enter the Group Listening feature code again.

Hold

Putting a call on hold

You can temporarily suspend a call.

1. Press .

When a call is on hold, its indicator flashes on all telephones that have access to the line. The call can be retrieved from any of these telephones.

Retrieving a held call

You can connect to a call on hold.

1. Press the flashing line button of the held call.

Holding automatically

You can switch from one call to another and have your calls put on hold automatically.

1. Press the line button of the caller you want to speak to. Your current caller is put on hold automatically.

Listening on hold

If you have been put on hold, you can hang up the receiver while you wait for the other person to return.

1. Press .
2. Hang up the receiver.
3. Press the line button of the call. You may hear indications from the far end that you are on hold (for example, tones or music).
4. When the person you were talking to returns you will hear them through your telephone speaker. Lift the receiver and talk.

Holding a call exclusively

You can put a call on Exclusive Hold so that it can be retrieved only at your telephone.

1. Press or . The line appears busy on all other telephones, and the call cannot be picked up by anyone else in the office.

Displays

On hold: LINENAM

You have placed one or more calls on hold.
The name of the line that has been held the longest is displayed.

Tips

On the M7100 telephone, alternates between two lines; one active, one on hold. The M7100 telephone cannot retrieve a call placed on hold by another telephone.

If Automatic Handsfree has been assigned to your telephone, use the Handsfree/Mute feature instead of Listen on Hold.

Host system signaling

You can access host systems, such as private branch exchanges (PBX) from Norstar by using host system signaling features (also known as end-to-end signaling). These features either send a special signal to the host system or allow you to program delays required by host systems in external autodial or speed dial sequences.

Link

Feature

If your Norstar system is connected to a private branch exchange (PBX), you can use a Link signal to access special features.

The Link signal can also be included as part of a longer stored sequence on an external autodial button or in a speed dial code. The Link symbol () uses two of the 24 spaces in a dialing sequence.

Pause

Feature

The Pause feature enters a 1.5 second delay in a dialing sequence on an external line. This is often required for signaling remote devices, such as answering machines, or when reaching through to PBX features or host systems.

You can program more than one pause in an external autodial or speed dial sequence.

The Pause symbol () uses one of the 24 spaces in a dialing sequence.

For pulse dialing, inserts a 1.5 second pause into the dialing sequence.

Programmed Release

Feature

The Programmed Release feature performs same function as in a programmed dialing sequence. When the system encounters Programmed Release in a dialing sequence, it stops dialing and hangs up the call.

The Programmed Release symbol () takes up two of the 24 spaces in a programmed dialing sequence.

Run/Stop

Feature * 9

Run/Stop inserts a break point into a sequence of dialed numbers or characters used for automatic dialing. This may be necessary when you are connecting to a PBX or similar host system.

For example, you may call a company with an automated attendant that instructs you to dial the internal number you need. You can program the company number, a Run/Stop, then the internal number on one external autodial button. Press the autodial button once to dial the company number. When you hear the automated attendant, press the autodial button again to dial the internal number.

The Run/Stop symbol (■) uses one of the 24 spaces in an autodial or speed dial sequence.

Wait for Dial Tone

Feature 8 0 4

Wait for Dial Tone causes a sequence of numbers to pause until dial tone is present on the line before continuing to dial. This is useful if you must dial a remote system and then wait for dial tone from that system before dialing the rest of your number.

The Wait for Dial Tone symbol (■) uses two of the 24 spaces in an autodial or speed dial sequence.

Displays

Invalid code

You have entered a code that can only be used in a programmed autodial or speed dial sequence, not on a call you dial directly. Programmed Release and Run/Stop are for use in programmed dialing sequences only.

Tips

If your external telephone lines use pulse dialing, you can temporarily switch to tone dialing by pressing after selecting the line. Tone dialing lets your Norstar telephone communicate with devices and services that respond to tone signals, such as automatic switchboards, and fax or answering machines.

If your Norstar system is connected to a private branch exchange (PBX), program Link onto a memory button for one-touch access.

Language choice

You can select the language used on the display of each Norstar telephone. Norstar supports three languages: English, French and Spanish. Button caps are available for each language.

English

Feature * 5 0 1

To select English as the language for your telephone display:

1. Press Feature * 5 0 1.

French

Feature * 5 0 2

To select French as the language for your telephone display:

1. Press Feature * 5 0 2.

Spanish

Feature * 5 0 3

To select Spanish as the language for your telephone display:

1. Press Feature * 5 0 3.

Displays

En español...	Telephone display messages will be in Spanish.
En français...	Telephone display messages will be in French.
In English...	Telephone display messages will be in English.

Tips

When your system is first installed, all telephones use English.

You can program a memory button for one-touch switching between languages. Program Feature * 5 0 1 onto the button. Press the button to change the language. You cannot program Feature * 5 0 2 or Feature * 5 0 3 onto a memory button.

Last Number Redial

Feature 5

Calling your last number

You can redial the last external number you dialed.

1. Press Feature 5 .

Displays

Hidden number

The last number you dialed was a speed dial number that displayed a name rather than the number. The number will be dialed correctly, but you cannot see it.

No last number

You have not dialed an external telephone number since the last power interruption or system reset.

Tips

If you have a programmed Last Number Redial button, you can use Button Inquiry (Feature *) to check the last number before you dial it.

Last Number Redial records a maximum of 24 digits.

You can copy a number onto an autodial button using Last Number Redial.

Line pools

Feature 6 4

Using a line pool

A line pool is a group of external lines that can be shared by many telephones. You can use a line in a line pool to make an external call.

1. Press Feature 6 4.
2. Enter a line pool access code.

If you have a free internal line, you can enter a line pool access code on an internal line. (You do not need the Line Pool feature code.)

Everyone in the office should have a list of the line pool access codes for the line pools their telephones can use.

Displays

Code:	Enter a line pool access code.
Denied in admin	Access to the line pool you requested is denied in programming. See your installer or customer service representative.
Invalid code	You have entered an invalid line pool access code.
Line in use	The line chosen by the system for your line pool request became active before connecting with your call. Retry the line pool request.
No button free	There is no free button on which the line pool line can appear.
No free lines	You have tried to access your line pool, but there are no lines in the line pool or all the lines are busy. Use Ring Again or call again later.

Tips

You do not usually need to enter the Line Pool feature code to use a line pool. Simply dial the line pool access code on an internal line.

To program an autodial or speed dial number to use a line pool, press and enter a line pool access code.

When you program a button with the line pool feature code, you must enter a line pool access code after the feature code. The programmed line pool button accesses a specific line pool, not the line pool feature.

If you program a button with a indicator to access a line pool, when all the lines in a line pool are busy, the indicator for the line pool button turns on. The indicator turns off when a line becomes available.

Your Norstar system can have 15 line pools, and a telephone can be programmed to access any number of them.

You can use a line pool only to make external calls.

If no lines are available in the line pool, you can use Ring Again at the busy tone. You will be notified when a line in the line pool becomes available. See Ring Again.

Your installer or service representative gives telephones access to line pools in Configuration programming. Each line pool is assigned a line pool access code in Configuration programming.

Line Redirection

Feature 8 4

Redirecting a line

Line Redirection lets you send your external calls to a telephone outside the office. You may choose to redirect all your external lines or only some of them.

1. Press Feature 8 4 .
2. Select the outgoing line to be used for redirected calls.
3. Enter the number to which calls will be redirected.
4. Select the lines to be redirected.

Canceling Line Redirection

Feature # 8 4

You can cancel Line Redirection.

1. Press Feature # 8 4 .
2. Select the lines that redirection is to be canceled for.

Displays while redirecting lines

9_
 QUIT BKSP OK

Continue entering digits. Press or **BKSP** to delete incorrect digits. Press Hold or **OK** when you are finished.

Access denied

You cannot perform line redirection on an M7100 telephone.

Denied in admin

Line Redirection is not allowed on your telephone. See your system coordinator.

Enter digits
 QUIT OK

Enter the telephone number to which you wish to redirect calls using one of the following methods:

Press an external autodial button.

Enter an external telephone number (max 24 digits) then press Hold or **OK**.

Press Hold or **OK** if the line you have chosen as the outgoing line is a private network line that does not require you to dial digits.

In use: 221	You have tried to program redirection while someone else is programming redirection. Only one person can program line redirection at a time.
Incoming only	The line you are trying to use for redirecting calls is for incoming calls only. Choose an outgoing line.
Intercom	You selected the intercom button as the facility to place the call on. Enter a line pool code or a destination code.
Invalid number	You have entered an invalid line pool code or an invalid destination code.
Line denied	You have selected a line that is private to another telephone. Only the owner of a private line can redirect it.
Line Redirection QUIT ADD REMOVE	Press * or ADD to begin redirection. Press # or REMOVE to cancel a previous redirection.
No line to use	You have one external line on your telephone, but you need a second line to perform line redirection. Redirect your external line using a line pool as the outgoing line.
Outgoing line	You are attempting to redirect a line and the line you have chosen is the outgoing line you have selected as a destination. You cannot redirect a line to itself. Select another line.
Pool code: _ QUIT	Enter a valid line pool access code.
Programmed	You have successfully redirected a line or successfully canceled redirection of a line.
Redir by 221 OVERRIDE	You have attempted to redirect a line, but someone else has already redirected that line. Press * or OVERRIDE to override the previous redirection and redirect the line as you wish.

Redirect denied	You have attempted to redirect calls on an incoming line group. You can only redirect calls on individual lines, you cannot redirect calls on an incoming line group.
Restricted call	The destination you have chosen for line redirection is restricted.
Select line out QUIT	<p>Select the line that will be used to redirect calls out of the system, using one of the following methods:</p> <ul style="list-style-type: none"> • Press an external line button. • Press <input type="text" value="intercom"/> and dial a line pool access code. • Press a line pool button. • Press an external autodial button.
Select line(s) QUIT ALL	Press the lines to be redirected. To undo a line selection, press it again. Press ALL to redirect all your lines.
Select line(s) ALL OK	Continue to press the lines to be redirected. Press <input type="text" value="Hold"/> or OK when you are finished.
Unequipped line	The line you are attempting to redirect cannot be redirected because the hardware does not support redirection.

Displays while canceling redirection

Redir by 221 OVERRIDE	This line is redirected by someone else. Press <input type="text" value="*"/> or OVERRIDE to cancel redirection of the line.
Select line(s) QUIT ALL	Press the lines that are no longer to be redirected. The lines light up as you press them. Once you cancel redirection for a line you cannot restore it by pressing the line again. Press ALL to cancel redirection for all your lines. When you are finished, press <input type="text" value="Hold"/> or OK .
Select line(s) ALL OK	Continue to press the lines that are no longer to be redirected. Press <input type="text" value="Hold"/> or OK when you are finished.

Tips

Note the differences between Line Redirection and Call Forward. Call Forward forwards all calls that arrive at a particular telephone to another telephone within the Norstar system. Line Redirection redirects only the lines you specify, no matter which telephones they appear on, to a telephone outside the Norstar system. Line Redirection takes precedence over Call Forward.

You redirect lines at a telephone, but once redirected, the lines are redirected for the entire system.

You can only redirect lines that appear at line buttons on your telephone.

You can answer the telephone if it rings while you are in the middle of programming Line Redirection, but none of the Norstar call handling features are available until the feature times out. If you need to use a Norstar feature to process the call, quit Line Redirection programming by pressing . Do not press or you will disconnect the call you are trying to process.

While you are programming Line Redirection you will not receive any indication of calls that do not actually ring at your telephone.

The system does not check that the number you give for Line Redirection is a valid one. If you redirect to an invalid number, redirection will fail. Using an autodial button to enter the redirection number helps avoid this possibility. An autodial button used for line redirection must have a specific line programmed onto it.

If you use **ALL** to redirect all your lines, it is important that you wait until all the lines on your telephone light up before pressing or **OK**. If you press or **OK** before all the lines light up, those lines not lit will not be redirected.

Be careful to avoid redirection loops. If for example, you redirect your lines to your branch office and your branch office redirects its lines to you, you can create a redirection loop. If these calls are long distance, you end up paying long distance charges needlessly.

The system can be set up so that redirected calls give a brief ring on telephones in the Norstar system as they are redirected. These calls cannot be answered within the system until you cancel redirection.

The line chosen for redirecting calls on other lines can still be used normally when it is not busy on a redirected call. To avoid redirection failing because the chosen line is in use, choose a line pool with several lines in it.

In certain situations, callers may experience lower volume levels when you redirect calls to an external location.

You cannot use the Line Redirection feature on an M7100 telephone, or a telephone connected to an ATA.

Long Tones

Feature 8 0 8

Using Long Tones

The Long Tones feature lets you control the length of a tone so that you can signal devices such as fax or answering machines which require tones longer than the standard 120 milliseconds.

1. While on a call, press Feature 8 0 8 .
2. Press the dial pad buttons to produce the appropriate tones. Each tone sounds for as long as you hold down the button.

Displays

Long Tones:

At the appropriate time, press any dial pad button. Hold each button down for as long as necessary. Press Feature or Hold to cancel Long Tones.

Make call first

You have tried to use Long Tones when you are not on a call.

Tips

Long tones can be used on any call except a conference call. You can use internal lines of the Norstar system to activate a device connected to an Analog Terminal Adapter in another area of your office, or external lines to access devices outside the Norstar system.

Messages

The Messages feature allows you to leave a message on the display of another Norstar telephone, and lets you know if you have any messages waiting. The Messages feature uses a message waiting list to keep a record of your internal messages and your (external) voice mail messages (if you subscribe to a voice message service with visual message waiting indication).

From your message waiting list, you can:

- view your messages
- call back the internal caller who left a message
- erase an internal message
- call your voice message center that left a message(s)
- clear a message sent by your voice message center (the message still remains at the center until it is erased there)

Sending a message

Feature 1

You can leave a message on the display of another telephone in your Norstar system.

1. Press Feature 1.
2. On a telephone with a two-line display, press **ADD**. (This step is not necessary on a telephone with a one-line display.)
3. Enter the internal number of the person you want to send the message to. The person's display reads **Message for you**.

Canceling a sent message

Feature # 1

You can cancel a message that you have sent to someone.

1. Press Feature # 1. The display reads **Cancel for:**
2. Enter the internal number of the person you sent the message to.

Viewing your messages

Feature 6 5

On a telephone with a one-line display:

1. Press Feature 6 5. The display shows the first message.
2. Press ***** or **#** to move through your messages.

On a telephone with a two-line display:

1. Press **MSG**. the display shows the first message you received.
2. Press **NEXT** to move through your message.

Replying to a message

You can call the person (or your voice message center) who sent a message while viewing the message.

On a telephone with a one-line display:

1. Press **0**.

On a telephone with a two-line display:

1. Press **CALL**.

If you wish to call your voice message center using a line other than the programmed line, exit your message list and dial the voice message center telephone number using normal dialing methods.

Removing items from your list

You can erase a message while you are viewing it in your message list. If the message is from your voice message center, this only erases the message notification at your telephone. You still need to erase the voice message at your voice message center. Refer to your voice message center documentation.

On a telephone with a one-line display:

1. Press **Hold**.

On a telephone with a two-line display:

1. Press **ERASE**.

Viewing your sent messages

Feature **1**

On a telephone with a two-line display, you can view the messages you have sent.

1. Press **Feature** **1**.
2. Press **SHOW** to display your first sent message.
3. Press **NEXT** to move through your sent messages.

Displays

1. 221 NEXT ERASE EXIT	You are reviewing the messages you have sent. Press * or * , or NEXT to view the next message. Press Hold or ERASE to erase the message on the display. Press 0 to call the person or voice message center.
221 called NEXT CALL ERASE	You are reviewing your messages. Press NEXT to see the next message. Press CALL to reply to the message. Press ERASE to erase the message.
Can't send ms9	You have tried to send a message to a Norstar Analog Terminal Adapter. The Norstar Analog Terminal Adapter does not have a display so it cannot show a message.
Cancel denied	You have entered an invalid number when attempting to cancel a message.
Cancel for:	Dial the internal number of the telephone you sent a message to and now want to cancel.
Cleared>LINENAM NEXT	You have cleared an external message from your message waiting list. The message itself still exists in your voice message center until you erase it there.
Erased> 221 NEXT	You have erased an internal message.
Hold or release	You have tried to access your message waiting list while on an active call. Hold or release the call.
In use: 221	You are trying to call from your message waiting list. The line that you are trying to use is being used by the identified Norstar user.
L001:LINENAMUMs9 NEXT CALL CLEAR	You are viewing your message list. The display shows the number and name of the line that was used for your voice mail message.
Message denied	You have tried to send a message to an invalid internal number or to a telephone that is out of service.

<p>Message for you MSG</p>	<p>You have one item in your message waiting list, and you have no new items in your Call Log. Press <input type="text" value="Feature"/> <input type="text" value="6"/> <input type="text" value="5"/> or MSG to review the message.</p>
<p>Message list SHOW ADD EXIT</p>	<p>SHOW appears only if you have outstanding messages. Press SHOW to review messages you have sent. Press ADD to send a new message.</p>
<p>Message to:</p>	<p>Enter the internal number of the telephone you want to send a message to.</p>
<p>Messages & Calls MSG CALLS</p>	<p>You have one or more messages and one or more new Call Logs.</p>
<p>Messages for you MSG</p>	<p>You have several new messages and no new Call Logs. Press <input type="text" value="Feature"/> <input type="text" value="6"/> <input type="text" value="5"/> or MSG to review the messages.</p>
<p>No button free</p>	<p>You have no line button free with which to reply to a message.</p>
<p>No messages</p>	<p>You do not have any messages to cancel or there are no messages to scan through.</p>
<p>No number stored</p>	<p>There has been no number programmed for the voice message center. To program the number, see the Programming chapter.</p>
<p>Release calls</p>	<p>You replied to a message while on an active call. Release your call before entering your message waiting list.</p>
<p>Start of list NEXT</p>	<p>You are at the beginning of your list of messages. Press NEXT to move through your messages.</p>
<p>Their list full</p>	<p>You are trying to send a message to a telephone whose message waiting list is full.</p>
<p>Your list full</p>	<p>You have tried to send a message but your telephone's list of sent messages is full. Cancel one of the messages you have sent, if possible, or wait until you have received a reply to one of those messages.</p>

Tips

You can send up to four messages to different telephones, including your voice message center. If your telephone is a direct-dial telephone or a central answering position, you can send up to 30 messages.

You can receive up to four messages from different telephones, including your voice message center. A single message from your voice message center may pertain to several voice messages.

Any message can be canceled either by the person who sent it or by the person who received it.

If your reply to a message is forwarded or is answered at another telephone using the Call Pickup feature, the message remains on your telephone until you cancel it or successfully contact the telephone that sent the message.

Moving line buttons

Feature * 8 1

You can move external lines to different buttons on your telephone. You can use this feature to arrange your lines in the way that makes the most sense to you.

1. Press Feature * 8 1 .
2. Press the button you want to move the line from.
3. Press the button you want to move the line to.

Displays

Exchanged	The two buttons you selected have exchanged position.
Invalid location	You have tried to move a line to a button that cannot be used as a line button, such as a Handsfree/Mute button, or an answer button.
Move line from: QUIT	Press the button of the line you want to move. Press Feature or QUIT when you have finished moving lines.
Move line to: QUIT	Press the button you want to move the line to. Neither of the buttons is erased. The lines, or the line and feature, simply switch places.
Press a line	The button you are trying to move is not a line button. If you are trying to switch a line and a feature, move the line to the feature button and not vice versa.

Tips

You cannot move intercom, answer or Handsfree/Mute buttons.

You cannot move incoming line group buttons onto a CAP module.

Page

Feature 6 0

Making a page announcement

You can make announcements over the Norstar system.

1. Press Feature 6 0.

2. Choose a page type.

Page types are:

1 through the telephone speakers (internal page)

2 through an external speaker (external page)

3 both internal and external (combined page)

3. If necessary, choose a zone.

4. Make your announcement.

5. Press Rls.

Displays

Denied in admin	Your telephone has not been programmed to allow paging.
Enter zone: ALL	Enter the desired zone number (0-6) or press ALL to page to all zones. (0 equals all zones.)
Invalid zone	You have entered a page zone code that is not between 0 and 6.
Page choice: SETS SPKR BOTH	Select the type of page you want by pressing: <input type="text"/> 1 or SETS — internal page <input type="text"/> 2 or SPKR — external page <input type="text"/> 3 or BOTH — combined page
Page timeout	The time allotted for paging has expired.
Paging ALL	You are making a page. The display shows the page zone you have chosen. Press <input type="text"/> Feature <input type="text"/> or <input type="text"/> Rls when you are finished.
Paging busy	A page is already being made in the page zone you have requested.

Tips

Instead of entering the Page feature code followed by the page type, you can enter the following shortcut codes.

Internal and zone (0 to 6)
External (code 2 has no zones)
Combined and zone (0 to 6)

You can make an announcement to one person by placing a voice call to their telephone.

Page zone 0 equals all zones.

When you make a page that uses external paging equipment (external page or combined page), the Long Tones feature is automatically activated for the external paging system only. This allows you to control optional equipment with the Long Tones feature.

Each Norstar telephone is assigned access to paging and is assigned to one of six page zones, or to none, in Administration programming.

Make sure that everyone who needs to make page announcements has a list showing which telephones are in which page zones.

Priority Call

Feature 6 9

If you get a busy signal or a Do Not Disturb message when you call someone in your office, you can interrupt them. Use this feature for urgent calls only.

Making a priority call

1. Press Feature 6 9.
2. Wait for a connection, then speak.

A person who receives a priority call while on another call has eight seconds to accept or reject the call. If the person does nothing, the Priority Call feature puts their active call on exclusive hold and connects your call.

Displays

Call blocked	You tried to place a priority call to another Norstar telephone. The person you called has blocked your call. Try to call later.
Denied in admin	You have tried to make a priority call, but this feature has not been assigned to your telephone.
Make call first	You have attempted to use the Priority Call feature before you made call.
Please wait	The party you are calling has eight seconds to decide whether to accept or reject your priority call.
Priority denied	The telephone you are calling has already received a priority call or is unable to receive priority calls.

Tips

If the telephone receiving the priority call is in a conference call, the other two parties are automatically put on hold when the priority call is accepted.

Each Norstar telephone is given permission to make priority calls in Administration programming.

You can make a priority call only while your telephone display shows one of the following prompts:

221 busy
PRIORITY LATER

Calling 221
PRIORITY LATER

Do not disturb
PRIORITY LATER

On another call
PRIORITY LATER

Privacy

Feature 8 3

Lines in your system can be configured to have automatic privacy. If a line is not programmed with privacy, anyone with the line assigned to their telephone can join your call, and form a conference by pressing the line button. If a line is programmed with privacy, only one person at a time can use the line.

Creating a conference by releasing privacy

If a line is programmed with privacy, you can turn privacy off for a call, allowing another person with the same line to join in your conversation and form a conference.

1. Press Feature 8 3 .
2. Tell the other person to press the line button and join your conversation.

Making a private call

If a line is programmed to not have privacy, you can turn privacy on for a call, preventing other people with the same line to join in your conversation.

1. Press Feature 8 3 .

Displays

Access denied	Privacy control cannot be used on internal or conference calls.
Make call first	You have tried to use the Privacy feature when you are not on a call.
Privacy is OFF	You have released privacy for your call.
Privacy is ON	You have turned privacy on for your call.

Tips

When a third person joins a conversation on a line that has privacy turned off, the call becomes a conference. All the rules applicable to a conference apply except that there is only one line in use, instead of the normal two. This means that you cannot split a conference set up using Privacy.

Ring Again

 Feature 2

If you can't get through to someone on your Norstar system because their telephone is busy or there is no answer, you can have the Norstar system tell you when they hang up or next use their telephone.

You can also use Ring Again to tell you when a busy line pool becomes available.

Turning on Ring Again

1. Press Feature 2 before you hang up.

Using Ring Again cancels any previous Ring Again requests at your telephone.

Canceling Ring Again

 Feature # 2

To cancel a Ring Again request:

1. Press Feature # 2 .

Displays

Can't ring again

You cannot use Ring Again on your current call. You can only use Ring Again while you have a busy signal on an internal call or line pool request, or while an internal call is ringing.

Ring Again?

YES NO EXIT

Press **YES** to use Ring Again. Press **NO** if you prefer to send a message.

Ring type

Feature * 6

You can choose one of four distinctive rings for your telephone. This makes it easier to identify your telephone in an open office.

Choosing a ring type

1. Press Feature * 6.
2. Choose the ring type you want.

Displays

Ring type: 1
NEXT OK

Press 1, 2, 3, 4 or NEXT. You hear the selected ring for two seconds. Repeat until you hear the ring you prefer, then press Hold or OK.

Ring volume

Feature * 8 0

You can set the volume at which your telephone rings.

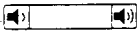
1. Press Feature * 8 0. The telephone rings.
2. Press  to adjust the volume.

Displays

Press VOLUME bar

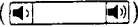
Press either side of the volume bar
() to adjust the volume.

Saved Number Redial

Feature

You can save the number of the external call you are on (providing you dialed the call) so that you can call it again later.

Saving a number

1. Press while you are still on the call.

Dialing a saved number

You can dial a saved number.

1. Press when you are not on a call.

Displays

Hidden number

You have saved a speed dial number that displays a name rather than the number. The number will be dialed correctly, but you cannot see it.

No number saved

You have tried to save the number of an incoming call. You can only save numbers that you have dialed yourself.

No saved number

You have tried to use Saved Number Redial, but have not first saved a telephone number. The Saved Number Redial memory is empty.

Tips

If you have a programmed Saved Number Redial button, you can use Button Inquiry (*) to check the last number before you dial it.

Saved Number Redial records a maximum of 24 digits.

You can copy a number onto an autodial button using Saved Number Redial.

Each telephone can save only one number at a time with Saved Number Redial, not one number for each line.

Service Modes

You can use Service Modes to make your Norstar system handle calls differently on different days and at different times of the day. Service Modes offers you three services: Ringing service, Restrictions service and Routing service.

Ringing service allows you to make additional telephones ring for incoming calls on external lines. For instance, all incoming external calls can also ring at a security guard's telephone during the night, or calls to one receptionist can also ring at another receptionist's telephone during lunch.

As part of Ringing service, you can also activate the Trunk Answer feature, an auxiliary ringer and an extra-dial telephone for each mode. The Trunk Answer feature lets you answer a ringing call anywhere in the system from any telephone in the system, whether or not you are using a line button for the line the call is on. Trunk Answer is only available for lines that have been placed in Ringing service, and then only if Trunk Answer is enabled for that mode. For each line, you can program an auxiliary ringer to ring for incoming calls. You can also activate an extra direct-dial telephone to ring for calls to a direct-dial telephone during a Ringing service mode. For more information on direct-dial and extra-dial telephones, see Telephone basics.

Restriction service allows you to assign alternative restrictions to lines and telephones, as well as alternate remote access packages.

Routing service allows you to assign alternate routes to calls that use the system's routing tables. In this way you can take advantage of lower costs available on particular routes on certain days and at certain times. The alternate routes are programmed by your installer or customer service representative.

Your system usually operates in normal mode. Service Modes offers you six additional modes. You can program which services are in effect during each mode in Administration programming.

You can activate each service manually from a control telephone, or you can create a schedule that automatically turns modes on and off at specified times for each day of the week. When you activate a service manually, you override the automatic schedule of modes. The Service Mode schedule is created in Administration programming.

For information on control telephones, see Special telephones in Telephone basics.

Activating Ringing service

1. From a control telephone, press .
2. Press **NEXT** to move through the Ringing service modes until the display shows the mode you want to activate.
3. Press **OK** to select the mode, or press **QUIT** to exit the feature without making any changes.

Canceling Ringing service

	<p style="text-align: center;">Do not confuse activating normal service with canceling a Service Mode</p> <p>Setting the Service Mode to Normal is not the same as canceling Ringing service using <input type="text" value="Feature"/> # <input type="text" value="8"/> <input type="text" value="7"/> <input type="text" value="1"/>. If you set the Service Mode to Normal, normal service overrides Ringing service and remains in effect until you manually cancel it, despite any automatic scheduling of alternative Service Modes. If you cancel Ringing service, you return to the automatic Service Mode schedule.</p>
---	---

1. From a control telephone, press # .

Activating the extra-dial telephone

You can redirect calls to your direct-dial telephone to an extra-dial telephone. If your telephone is also a control telephone, this will also activate Ringing service.

1. From a direct-dial telephone, press .

Activating Restriction service

1. From a control telephone, press . The display reads **Password:**.
2. Enter the Administration password.
3. Press **NEXT** to move through the Restriction service modes until the display shows the mode you want to activate.
4. Press **OK** to select the mode, or press **QUIT** to exit the feature without making any changes.

Canceling Restriction service

	<p style="text-align: center;">Do not confuse activating normal service with canceling a Service Mode</p> <p>Setting the Service Mode to Normal is not the same as canceling Restriction service using <input type="text" value="Feature"/> # <input type="text" value="8"/> <input type="text" value="7"/> <input type="text" value="2"/>. If you set the Service Mode to Normal, normal service overrides Restriction service and remains in effect until you manually cancel it, despite any automatic scheduling of alternative Service Modes. If you cancel Restriction service, you return to the automatic Service Mode schedule.</p>
---	---

1. Press # .
2. Enter the Administration password.

Activating Routing service

1. From a control telephone, press . The display reads **Password:**.
2. Enter the Administration password.
3. Press **NEXT** to move through the Routing service modes until the display shows the mode you want to activate.
4. Press **OK** to select the mode, or press **QUIT** to exit the feature without making any changes.

Canceling Routing service

	<p style="text-align: center;">Do not confuse activating normal service with canceling a Service Mode</p> <p>Setting the Service Mode to Normal is not the same as canceling Routing service using <input type="text" value="Feature"/> <input type="text" value="#"/> <input type="text" value="8"/> <input type="text" value="7"/> <input type="text" value="3"/>. If you set the Service Mode to Normal, normal service overrides Routing service and remains in effect until you manually cancel it, despite any automatic scheduling of alternative Service Modes. If you cancel Routing service, you return to the automatic Service Mode schedule.</p>
---	--

1. From a control telephone, press .

Viewing the active Service Modes from a two-line display telephone

When a Service Mode is active, the control telephone display reads **Service Modes ON**.

1. Press **MODES**. The display shows the first active Service Mode.
2. If there are several active Service Modes, press **NEXT** to move through the modes.
3. Press **EXIT** to exit the feature.

Viewing the active Service Modes from a one-line display telephone

1. Press . The display reads **Service Modes ON**.
2. Press . The display shows the first active Service Mode.
3. Press to move through the active Service Modes.
4. Press to exit.

Displays

<Mode> Restr'n
EXIT NEXT

You are viewing the active Service Modes. Press **#** or **NEXT** to see the other active Service Modes. Press **RIS** or **EXIT** to quit.

<Mode> Restr'n
QUIT OK NEXT

The name of the current Restriction service mode is displayed. Press **#** or **NEXT** to see the other Ringing service modes. Press **Hold** or **OK** to select the desired mode.

<Mode> Ringing
EXIT NEXT

You are viewing the active Service Modes. Press **#** or **NEXT** to see the other active Service Modes. Press **RIS** or **EXIT** to quit.

<Mode> Ringing
QUIT OK NEXT

The name of the current Ringing service mode is displayed. Press **#** or **NEXT** to see the other Ringing service modes. Press **Hold** or **OK** to select the desired mode.

<Mode> Routing
EXIT NEXT

You are viewing the active Service Modes. Press **#** or **NEXT** to see the other active Service Modes. Press **RIS** or **EXIT** to quit.

<Mode> Routing
QUIT OK NEXT

The name of the current Routing service mode is displayed. Press **#** or **NEXT** to see the other Ringing service modes. Press **Hold** or **OK** to select the desired mode.

<Mode> until *
QUIT OK NEXT

Press **Hold** or **OK** to select this Service Mode, **#** or **NEXT** to see the next available Service Mode, or **RIS** or **QUIT** to exit. If you select this mode it will be in effect until the next automatic Service Mode takes effect.

Denied in admin

You are trying to activate a Service Mode from a telephone that is not a control telephone or direct-dial telephone, all service modes are disabled in Administration programming, or you are trying to activate Ringing service from a control telephone that has no lines assigned to it.

No services ON

You have entered the Show Service Modes feature code and there is no active mode.

Password: _

You have entered the Restriction service or Routing service feature code. Enter the Administration password.

**Service Modes ON
MODES**

There is a Service Mode active in your system. Press ***** or **MODES** to view the active Service Modes.

Tips

The system coordinator sets up Service Modes in Administration programming. Restrictions used in Restriction service are programmed by the system coordinator in Administration programming. Routes used in Routing service are programmed by your installer or customer service representative.

Ringing service makes additional telephones ring for incoming external calls. It does not suppress your normal ringing assignment.

Automatic service modes are indicated by an asterisk (*) before the name of the service mode on the display. You can neither manually activate nor cancel automatic service modes, although you can override them with manual modes.

The control telephone can override automatic service modes at any time by entering a Service Modes feature code, and selecting a different mode; this override remains in effect until it is canceled. If you select a mode with an asterisk (*), the next automatic service mode comes into effect at the programmed time.

Direct-dial calls to a direct-dial telephone ring at the extra-dial telephone (designated in Administration programming) only when you enter the Ringing service feature code (**Feature**) at that direct-dial telephone. Note that only the extra-dial telephone is activated, not the actual service mode (unless that direct-dial telephone is also a control telephone).

Norstar provides six service modes named Night, Lunch, Evening, Mode 4, Mode 5, and Mode 6. The system coordinator can change these names to suit your business.

You can program the Trunk Answer feature to be available during Ringing service in Administration programming. For information on using Trunk Answer, see the Trunk Answer section.

Speed Dial

Feature 0

Making a speed dial call

You can quickly dial external telephone numbers that have been programmed onto speed dial codes.

1. Press 0 .
2. Enter the appropriate two-digit speed dial code.

Norstar provides two types of speed dial: system and personal. System speed dial codes are from 01 to 70. The system coordinator assigns numbers to system speed dial codes for the entire system in Administration programming. Personal speed dial codes are from 71 to 94 and may have different numbers assigned to them on each telephone. Users can program their own personal speed dial numbers.

Programming Personal Speed Dial

Feature * 4

You can add or change a personal speed dial number on your telephone.

1. Press * 4 .
2. Enter the code that you want to associate with a telephone number.
3. If you want to include a line selection for this number, press the line or intercom button. To select a line pool, press a programmed line pool button, or press and enter a line pool access code. For the M7100 telephone, you can only select a line pool.
4. Enter the number you want to program.
5. Press or **OK**.

Displays

9_
QUIT BKSP OK

Continue entering the number you wish to program. You can change the number by pressing **BKSP** or . When you are finished, press or **OK**.

Access denied	You have tried to program a personal speed dial number while someone else on the system is in Configuration or Administration programming.
Autodial full	You have tried to enter a new personal speed dial number, but the memory for these numbers in your system is full.
Enter code:	Enter a two-digit code (71 to 94) for the personal speed dial number you want to program.
Enter digits QUIT OK	Enter the telephone number you wish to program exactly as you would if you were dialing it normally. When you are finished, press <input type="text" value="Hold"/> or OK .
Invalid code	You have entered a code outside the code range (01-70 for system, 71-94 for personal).
Line in use	The line associated with the speed dial number you are trying to use is busy.
No number stored	There is no number stored on the speed dial code you have dialed.
Program and HOLD	If you want to program a line or line pool selection for this speed dial number, select the line or line pool. Otherwise, enter the telephone number exactly as you would if you were dialing it normally. When you are finished, press <input type="text" value="Hold"/> .
Program and OK QUIT OK	If you want to program a line or line pool selection for this speed dial number, select the line or line pool. Otherwise, enter the telephone number you wish to program exactly as you would if you were dialing it normally. When you are finished, press OK .
Select a line	There is no line associated with the speed dial number you are trying to use. Select a free external line or line pool and enter the Speed Dial feature code again.
Speed dial>	Enter a two-digit speed dial code (01-94). You must enter the zero for codes 01 to 09.
Unknown number	The system cannot dial the number stored. Reprogram the number.

Tips

There is no difference between using personal speed dial and using system speed dial. They differ only in how you program them.

Speed dial numbers may include host system signaling codes.

To program a speed dial number for a line pool, press a programmed line pool button or press and enter the line pool access code. Do not use the line pool feature code.

Although it may look like an internal number, you can program a destination code as a speed dial number, since it is actually an external number. In programming, you must press as the line to use for dialing the destination code.

Speed dial numbers are subject to the same dialing filters as regularly dialed numbers. System speed dial numbers can be programmed to bypass dialing restrictions.

Normally, speed dial numbers are shown on the display while they are being dialed. System speed dial numbers may be programmed to show a name instead of the number, keeping the actual number confidential.

Time

Feature 8 0 3

You can display the current date and time while you are on a call.

1. Press Feature 8 0 3 .

Displays

Apr 9 9:54 am

The display shows the current date and time.

Transfer

Feature 7 0

Transferring a call

You can transfer a call to a telephone in your Norstar system, within the Norstar network, or external to Norstar:

1. Press Feature 7 0 .
2. Call the person you want to transfer the call to.
3. If you want to talk to the person you are transferring the call to, wait for them to answer, and speak to them before proceeding.
4. When you are ready to complete the transfer, press **RLS** or **JOIN**.

Canceling a transfer

You can reconnect to the person you are trying to transfer at any time before the transfer is complete.

1. Press Feature # 7 0 or **CANCL**.
2. If you are not reconnected to your original call, press **RLS** and then press the line key of the original call, which is now on hold.

Displays

221 > 222
CANCL RETRY JOIN

You are talking to the person you want to transfer the call to. Press **RETRY** if you decide to transfer the call to someone else. Press **RLS** or **JOIN** to transfer the call.

221 busy
CANCL RETRY JOIN

All the lines on the telephone you are trying to call are busy. Press **RETRY** to enter a new internal number. Press **JOIN** to transfer the call anyway.

221 hung up
CANCL RETRY

The internal caller you were trying to transfer hung up before the transfer was complete.

221 no reply
CALLBACK

The person to whom you tried to transfer a call did not answer. Press **CALLBACK** or the flashing line button to reconnect to the call. On the M7100 telephone, lift the receiver.

Call transferred

The transfer was successfully completed.

182 / Transfer

<p>Do not disturb CANCL RETRY JOIN</p>	<p>The person you tried to transfer a call to has Do Not Disturb active on their telephone. Press <u>JOIN</u> to transfer the call anyway. Press <u>RETRY</u> to transfer the call to someone else. Press <u>CANCL</u> or the flashing line button to reconnect to the call (on the M7100 telephone, press <input type="text" value="Feature"/> # <input type="text" value="7"/> <input type="text" value="0"/>).</p>
<p>Invalid number CANCL RETRY</p>	<p>You entered an invalid internal number. Press <u>RETRY</u> and enter the number again.</p>
<p>Line001 hung up</p>	<p>The external caller you were transferring hung up before the transfer was complete.</p>
<p>Line001>221 CANCL RETRY JOIN</p>	<p>Press <u>JOIN</u> to transfer the call on line 001 to telephone 221. Press <u>RETRY</u> if, after talking to the person at extension 221, you decide to transfer the call to someone else.</p>
<p>Make call first</p>	<p>You have tried to use the Transfer feature when you have no call to transfer.</p>
<p>Not in service CANCL RETRY</p>	<p>The telephone to which you are trying to transfer a call is out of service.</p>
<p>Restricted call CANCL RETRY</p>	<p>You cannot transfer the call because of telephone or line restrictions.</p>
<p>Still in transfer CANCL RETRY</p>	<p>Complete the transfer in progress before you access a new feature, answer another alerting call or select an outgoing line.</p>
<p>Transfer denied CANCL RETRY</p>	<p>Your transfer cannot be completed for one of these reasons:</p> <ul style="list-style-type: none"> • All the resources needed to perform a transfer are in use. Try again later. • You have tried to transfer an external call to another external party. Some restrictions apply. See Tips at the end of this section. • You cannot transfer your conference call. See Tips at the end of this section.
<p>Transfer to: CANCL</p>	<p>Enter the internal number of the person you want to transfer the call to. Press <u>CANCL</u> to cancel the transfer and return to your call.</p>
<p>Transfer to:22_ CANCL RETRY</p>	<p>Press <u>RETRY</u> if you entered the wrong internal number or if the person you are transferring the call to is unavailable.</p>

Tips

If an external call is transferred to a busy telephone, or not answered after a few rings, the call automatically rings you back and the display indicates that the telephone was busy or that no one answered.

While on a conference call, you can remove yourself from the conference and connect the other two callers using the Transfer feature. However, if both of the other people are from outside the system, at least one of the outside callers must have called you and that call must be on a disconnect supervised line.

When transferring an external call to an external number, the external call you are trying to transfer must have been an incoming call on a disconnect supervised line.

In certain situations, you may experience lower volume levels when using transferring an external call to an external person, or when transferring two external callers from a conference call.

Depending on how a private network call is routed, it may not always be possible for the system to return a transferred call to you if the transferred call is not answered. When transferring a call to a private network destination, it is a good idea to stay on the line until the person you are transferring the call to answers your call.

You cannot use Last Number Redial, Saved Number Redial, or a speed dial code when calling the person you want to transfer a call to.

You cannot use the Line Pool feature code to access a line pool when calling the person you want to transfer a call to. To use a line pool, use a programmed line pool button, or press and enter a line pool access code.

You cannot use Priority Call or Ring Again when calling the person you want to transfer a call to.

If you have an auxiliary ringer programmed to ring for calls on an external line, and you transfer a call on that line without announcing the transfer, the auxiliary ringer will ring for the call transfer.

Trunk Answer

Feature

The Trunk Answer feature lets you answer a ringing call anywhere in the system from any telephone in the system, whether or not you are using a line button for the line the call is on. Trunk Answer is only available for lines that have been placed in a Service Mode, and then only if Trunk Answer is enabled for that Service Mode.

To answer a call using Trunk Answer:

1. Press .

Displays

Line denied	You have tried to pick up a call on someone else's private line.
No button free	You have tried to pick up a call when you have no line button available.
Pickup denied	The call that is ringing is on a line that is not in a Service Mode.

Tips

If there is more than one incoming call on lines in a Service Mode, the Trunk Answer feature picks up the external call that has been ringing the longest.

Trunk Answer works only with calls that are ringing on lines for which a Service Mode is active and if Trunk Answer is enabled in Administration programming.

Voice Call

Feature 6 6

Making a voice call

You can make an announcement or begin a conversation through the speaker of another telephone in the system.

1. Press Feature 6 6.

Muting voice call tones

When a voice call begins at your telephone, you hear a beep every 15 seconds as a reminder that the microphone is on. You can stop it beeping.

1. Pick up the receiver or press Handsfree Mute.

Answering a voice call without touching your telephone

If Handsfree Answerback is assigned to your telephone, you can respond to a voice call without touching the telephone.

1. When someone makes a voice call to you, simply start talking. Your telephone's microphone picks up your voice.

Preventing voice calls to your telephone

Feature 8 8

You can prevent your telephone from receiving voice calls.

1. Press Feature 8 8. Voice calls will ring like regular internal calls. Your other calls proceed normally.

Canceling Voice Call Deny

Feature # 8 8

You can cancel Voice Call Deny.

1. Press Feature # 8 8.

Displays

Dial voice call

Dial the internal number or press the internal autodial button of the person to whom you want to speak.

Microphone muted

Your handsfree microphone is muted. Press Handsfree Mute or pickup your receiver to respond to the voice call.

186 / Voice Call

No voice call

The telephone receiving the call cannot accept voice calls for one of the following reasons: it is active or ringing with another call; it is in Call Forward mode; it is in Do Not Disturb mode; it has Voice Call Deny turned on; it is not a Norstar telephone.

Your call proceeds automatically as a regular ringing call.

Voice call

The line is open for you to speak.

Tips

Once you have answered a voice call, you can put it on hold, transfer it, or otherwise treat it as a normal call.

The system coordinator assigns Handsfree Answerback to a telephone in Administration programming. You can not assign Handsfree Answerback capability to the M7100 telephone.

User cards

This chapter includes reproductions of the *Telephone Feature Card*, the *Prime Telephone User Card* and the *Norstar Telephone User Cards*. You can photocopy parts of this chapter for co-workers who do not have the original cards.

To best assist your co-workers, you should familiarize yourself with general Norstar feature operation and with the specific operation of each Norstar telephone model.

188 / Telephone Feature Card

Using Norstar features

Using a Norstar* feature

- Press and enter the desired feature code on the dial pad.
or
Press a programmed memory button.
- Follow the display messages.

On a two-line display telephone, some features are also available on display buttons.

Programming memory buttons

You can program memory buttons for one-touch access to frequently used features.

- Press * .
- Press the memory button that you want to program. (This step is not necessary on the M7100 telephone.)
- Press and enter the feature code on the dial pad.

You can also program frequently dialed numbers, using the following codes:

* External autodial: Store an external number for one-touch dialing.
 * Internal autodial: Store an internal number for one-touch dialing.
 See your Telephone User Card for details.

* You cannot program line, incoming line group, intercom, answer, or Handsfree/Mute buttons.

Norstar features

- | | | | |
|-------------------------------|--|--|--|
| Background Music | <input type="text" value="Feature"/> <input type="text" value="8"/> <input type="text" value="6"/> | Cancel <input type="text" value="Feature"/> * <input type="text" value="8"/> <input type="text" value="6"/> | |
| | Listen to music (provided by your office) through your telephone speaker when you are not on a call. | | |
| Button Inquiry | <input type="text" value="Feature"/> * <input type="text" value="0"/> | | |
| | Check what is programmed on any button. Use when labeling buttons. | | |
| Call Duration Timer | <input type="text" value="Feature"/> <input type="text" value="7"/> <input type="text" value="7"/> | | |
| | Briefly display the approximate length of your current or most recent call. | | |
| Call Forward | <input type="text" value="Feature"/> <input type="text" value="4"/> | Cancel <input type="text" value="Feature"/> # <input type="text" value="4"/> | |
| | Send your calls to another telephone in your Norstar system. | | |
| Call Park | <input type="text" value="Feature"/> <input type="text" value="7"/> <input type="text" value="4"/> | | |
| | Put a call on hold so that it can be picked up from any telephone in your Norstar system. The display shows a three-digit retrieval code.
To retrieve a parked call, press <input type="text" value="intercom"/> and dial a retrieval code on any telephone in your Norstar system. On the M7100 telephone, just lift the receiver and dial the retrieval code. | | |
| Call Pickup - directed | <input type="text" value="Feature"/> <input type="text" value="7"/> <input type="text" value="6"/> | | |
| | Answer any ringing telephone.
Press <input type="text" value="Feature"/> <input type="text" value="7"/> <input type="text" value="6"/> and dial that telephone's extension number. | | |
| Call Pickup - group | <input type="text" value="Feature"/> <input type="text" value="7"/> <input type="text" value="5"/> | | |
| | Answer a call that is ringing at another telephone in your pickup group. The external call that has been ringing longest is answered first. | | |

Telephone Feature Card / 189

Call QueuingFeature 8 0 1

Answer the next call. If more than one call is waiting, priority is given to incoming external calls over callback, camped, or transferred calls.

Camp-onFeature 8 2

Re-route a call to another telephone even if all its lines are busy.

Press Feature 8 2, then dial the extension number of the receiving telephone.

Class of service passwordFeature 6 8

Change the dialing filters on a line or telephone, or gain external access to your system. Dialing filters determine which numbers you can dial.

Press Feature 6 8 and enter a password provided by your system coordinator to change your class of service.

ConferenceFeature 3

Establish a conference call between yourself and two other parties.

1. Make or answer the first call.
2. Put the first call on hold.
3. Make or answer the second call.
4. After the second call is connected, press Feature 3.
5. Press the line or intercom button of the first held call (not required on the M7100 telephone).
6. Press Ris to end the conference call.

To remove yourself from a conference permanently (unsupervised conference):

Press Feature 7 0. The other two callers remain connected. (Some external lines may not support this feature. See your system coordinator.)

To put a conference on hold:

Press Hold. The other two callers can still talk to each other.

To split a conference:

Press the line or intercom button of one caller to consult privately while the other caller is on hold. To re-establish the conference, press Feature 3.

To disconnect one party:

Press the line or intercom button of the caller you want to disconnect, then press Ris.

Press the line or intercom button of the remaining caller to resume your conversation.

To independently hold two calls:

Press the line or intercom button of the first caller, then press Hold. The second caller is automatically put on hold. To re-establish the conference, retrieve one call from hold, press Feature 3, then retrieve the second call from hold.

Contrast adjustmentFeature * 7

Adjust the contrast of your display.

Press Feature * 7, then press a number from 1 to 9 (depending on your telephone). Press Hold to set your choice.

Dialing modesFeature * 8 2

Choose one of three methods of dialing.

1. Press Feature * 8 2.
2. Press # to select the mode.
3. Press Hold to store the mode.

Standard Dial: Select a line, then dial the number. (Standard Dial is always available, even when another dialing mode is selected.)

190 / Telephone Feature Card

Automatic Dial: Dial the number without choosing a line button first. Your prime line is automatically selected for the call.

Pre-Dial: Dial the number, then press a line button to place the call. Edit the number by pressing **[←]** **[→]** before placing the call.

Do Not Disturb Feature **Cancel** Feature
 When you are not on a call prevent incoming calls, except priority calls, from ringing at your telephone. When you are on a call, block an incoming priority call.

Group Listening Feature **Cancel** Feature
 Use both the receiver and speaker while you are on a call. To avoid electronic feedback, keep the receiver away from the speaker during the call, and press **[Ris]** to hang up.

Hold
 Temporarily suspend a call.
 To retrieve a held call, press the line button for the held call. (Press on the M7100 telephone.)

Exclusive Hold
 Feature or Feature
 Temporarily suspend a call and prevent other telephones from picking it up.

Language Choice Feature
 Select English as the language for the telephone display.
 Feature
 Select French as the language for the telephone display.
 Feature
 Select Spanish as the language for the telephone display.

Last Number Redial Feature
 Automatically redial the last external telephone number that you dialed.

Line pools Feature
 With a line pool, telephones can share several lines for making calls.
 1. Press Feature or **Intercom**.
 2. Enter a line pool access code. (See your system coordinator for a list.)

Line Redirection Feature **Cancel** Feature
 Send calls arriving on an external line to another telephone outside your Norstar system. (Some external lines may not support this feature. See your system coordinator.) This feature is not available on the M7100 telephone.

Link Feature
 Generate a Link signal **[Lk]** to access a PBX or other host exchange.

Long Tones Feature
 Generate a tone for as long as you hold down a button. This is used to communicate with devices like fax or answering machines. Long tones are in effect only for your current call.

Telephone Feature Card / 191

Messages

Feature [] [] 1

Cancel Feature [] # [] 1

Send a message to a Norstar telephone's display to have someone call you back.

To view and reply to your messages:

1. Press Feature [] [] 6 [] 5 [] .
2. Press * and # to view your message list.
3. Press 0 to call the person who left you the message.

To erase a message:

1. Press Hold [] while viewing a message.

Moving line buttons

Feature [] * [] 8 [] 1

Change the position of your line or incoming line group buttons.

1. Press Feature [] * [] 8 [] 1 .
2. Press the line button that you want to move.
3. Press the button that you want to move the line to.
4. Press [Ris]. The two buttons are exchanged.
5. Switch the button caps.

Line buttons cannot be exchanged with intercom, answer or Handsfree/Mute buttons.

Page

Feature [] [] 6 [] 0 and code (1 to 3) and zone (0 to 6)

Make a page announcement through either the internal (code 1) or external (code 2) speakers, or both (code 3). Zone 0 pages all zones.

Internal page

Feature [] [] 6 [] 1 and zone (0 to 6)

Make a page announcement to all, or to a specific group of, Norstar telephones, through the telephone speakers. Zone 0 pages all zones.

External page

Feature [] [] 6 [] 2

Make a page announcement through an external loudspeaker system.

Internal and external page

Feature [] [] 6 [] 3 and zone (0 to 6)

Make a page announcement through both your Norstar telephone speakers and an external loudspeaker system. Zone 0 pages all zones.

Pause

Feature [] [] 7 [] 8

Program in an external autodial sequence to insert a 1.5 second delay ☺.

For pulse dialing: * also inserts a 1.5 second delay.

Priority Call

Feature [] [] 6 [] 9

Interrupt a person who is on a call or using Do Not Disturb.

A person on another call can press Feature [] [] 8 [] 5 to block your priority call.

Privacy

Feature [] [] 8 [] 3

Change the privacy setting for an external line. If a line normally has privacy, this permits another telephone that shares the line to join your call by selecting the line while you are using it. If a line normally has privacy disabled, this prevents another telephone that shares the line from joining your call by selecting the line while you are using it. The privacy setting is re-established once you end your call or when you enter the Privacy feature code again.

192 / Telephone Feature Card

Programmed Release	Feature <input type="text"/> * <input type="text"/> 8 <input type="text"/> 9
	Program at the end of an external autodial number to automatically release ■ the call.
Ring Again	Feature <input type="text"/> 2 Cancel Feature <input type="text"/> # <input type="text"/> 2
	Monitor a busy or unanswered telephone, or a busy line pool within your system. Ring Again signals you to call back when the telephone or line pool becomes available.
Ring type	Feature <input type="text"/> * <input type="text"/> 6
	Select a distinctive ring to help differentiate between your telephone and others nearby. 1. Press Feature <input type="text"/> * <input type="text"/> 6. 2. Enter the ring type number (<input type="text"/> 1 to <input type="text"/> 4). 3. Press Hold .
Ring volume	Feature <input type="text"/> * <input type="text"/> 8 <input type="text"/> 0
	Make your telephone ring so that you can adjust the volume. You can also adjust the volume any time your telephone rings.
Run/Stop	Feature <input type="text"/> * <input type="text"/> 9
	Store more than one autodial number or external carrier feature code on one memory button by inserting a break point ■ between numbers or codes. The first press of the button dials the first number or code; the next press dials the next number or code. You can program up to four numbers or codes separated by break points.
Saved Number Redial	Feature <input type="text"/> 6 <input type="text"/> 7
	Save a number to redial later. Enter the code while you are on a call that you have dialed to save the number. Enter the code when you are not a call to redial the saved number.
Service Modes	Show service modes Feature <input type="text"/> 8 <input type="text"/> 7 <input type="text"/> 0
	Display the modes that have been turned on at a designated control set.
	Extended ringing Feature <input type="text"/> 8 <input type="text"/> 7 <input type="text"/> 1 Cancel Feature <input type="text"/> # <input type="text"/> 8 <input type="text"/> 7 <input type="text"/> 1
	Turn on one of six modes for alternative ringing/call answering arrangements from a designated control telephone.
	Alternative restrictions Feature <input type="text"/> 8 <input type="text"/> 7 <input type="text"/> 2 Cancel Feature <input type="text"/> # <input type="text"/> 8 <input type="text"/> 7 <input type="text"/> 2
	Turn on one of six modes for alternative restrictions on particular lines or telephones from a designated control telephone. You will be required to enter the Administration password.
	Alternative routing Feature <input type="text"/> 8 <input type="text"/> 7 <input type="text"/> 3 Cancel Feature <input type="text"/> # <input type="text"/> 8 <input type="text"/> 7 <input type="text"/> 3
	Turn on one of six modes for alternative routing on particular lines or telephones from a designated control telephone. You will be required to enter the Administration password.
Speed Dial	Feature <input type="text"/> 0
	Dial an external telephone number using a two-digit code. There are two types of speed dial codes: system (01 to 70) and personal (71 to 94). System speed dial codes can be used from any Norstar telephone in the system. They are assigned by your system coordinator. Personal speed dial codes are used exclusively at your telephone.

To make a call using a speed dial code:

1. Press **Feature** .
2. Enter the two-digit code for the number (01 to 70 for system speed dial, 71 to 94 for personal speed dial).

To program personal speed dial numbers:

1. Press **Feature** .
2. Enter a two-digit code from 71 to 94.
3. Specify the external line by pressing a line button, a line pool button, or the intercom button. If you don't specify the external line, the system automatically chooses a line for the call.
4. Dial the telephone number you want to program (up to 24 digits).
5. Press **Hold** .
6. Record the code and number you have just programmed.

You cannot program personal speed dial numbers while someone else is programming your Norstar system.

Time

Feature

Briefly display the time and date while you are on a call.

Transfer

Feature

Send a call to another telephone within your Norstar system, or to an external telephone. You may not be able to transfer a call on an external line to an external telephone, depending on the capabilities of the lines.

1. Make or answer a call.
2. Press **Feature** .
3. Call the person you want to transfer the call to.
4. Stay on the line if you wish to speak to the person first.
5. Press **Ris** to complete the transfer.

If an external call is transferred to a busy internal or network extension, or is not answered after a few rings, the call automatically rings you back.

Trunk Answer

Feature

Answer an external call that is ringing on a line that has been placed into a Service Mode from any telephone in your Norstar system. This feature does not work for a private line.

Voice call

Feature

Make a voice announcement or begin a conversation through the speaker of another Norstar telephone without first making the other telephone ring.

Voice call deny

Feature

Cancel **Feature**

Prevent your telephone from receiving voice calls.

Do Not Disturb (**Feature**) also prevents your telephone from receiving voice calls.

Wait for dial tone

Feature

Program in an external autodial number to cause the system to wait to receive dial tone **■** from another system before proceeding with the dialing sequence.

194 / Telephone Feature Card

Call Display Services

The following features are available only if you subscribe to Call Display services from your local telephone company.

Autobumping	Feature <input type="text" value="8"/> <input type="text" value="1"/> <input type="text" value="5"/>	Cancel Feature <input type="text" value="#"/> <input type="text" value="8"/> <input type="text" value="1"/> <input type="text" value="5"/>
	Have the system automatically delete the oldest log entry from a full Call Log, so that a new log entry can be stored.	
Call Information	Feature <input type="text" value="8"/> <input type="text" value="1"/> <input type="text" value="1"/>	
	Display the name, number or line name of a ringing or held call. Press <input type="text" value="#"/> to move through the information displays.	
Call Log	Feature <input type="text" value="8"/> <input type="text" value="1"/> <input type="text" value="2"/>	
	Call Log displays use the following special characters:	
	<u>1</u> (underline) identifies a new item 5 identifies answered calls S identifies long distance calls / identifies that the information has been shortened	
	To view your Call Log:	
	1. Press <input type="text" value="*"/> to view old items. Press <input type="text" value="#"/> to view new items. Press <input type="text" value="0"/> to return to the last viewed item. 2. Press <input type="text" value="#"/> and <input type="text" value="*"/> to move through your items. 3. Press <input type="text" value="◀"/> <input type="text" value="▶"/> to view more information on an item.	
	To erase a Call Log item:	
	1. Press <input type="text" value="Hold"/> while viewing an item.	
	To return a call from your Call Log:	
	1. Display the desired number on your telephone. 2. Edit the number, if required. You can add numbers for long distance dialing or line pool access or remove numbers using <input type="text" value="◀"/> <input type="text" value="▶"/> .	
	3. Press a line button.	
	4. Lift the receiver.	
Call Log options	Feature <input type="text" value="*"/> <input type="text" value="8"/> <input type="text" value="4"/>	
	Select the type of calls that will automatically be stored in your Call Log. Press <input type="text" value="#"/> to see the next setting. Press <input type="text" value="Hold"/> to select the displayed setting.	
Call Log password	Feature <input type="text" value="*"/> <input type="text" value="8"/> <input type="text" value="5"/>	
	Program a four-digit password for your Call Log. To remove a forgotten password, see your system coordinator.	
Logit	Feature <input type="text" value="8"/> <input type="text" value="1"/> <input type="text" value="3"/>	
	Store caller information for your current call in your Call Log.	

*Meridian and Norstar are trademarks of Northern Telecom

Using your prime telephone

Your telephone has been programmed as a prime telephone for particular external lines on your system. This means that any external call on those lines that is not answered, or gets transferred, parked, or put on hold and is not picked up, or any call that for one reason or another is not being handled, rings at your telephone. Your system can have several prime telephones.

Understanding rings and indicators

Your telephone rings differently for different types of calls. External calls ring normally, internal calls give two short rings. Redirected external calls ring as internal calls.

The indicator beside a button tells you the status of a call on a line, line pool, answer, or intercom button.

lit	The line is active on a call.
fast flash	You have put a call on hold on that line.
medium flash	There is an incoming call.
slow flash	Somebody else has put a call on hold on that line.
unlit	The line is available.

Interpreting display messages

When an unanswered call rings at your telephone, you may see one of the following displays:

DND from 223	The person at telephone 223 has forwarded a call to you using Do Not Disturb.
DND transfer	The system transferred a call to you from a telephone in Do Not Disturb mode.
DRT Line001	Nobody answered this call, so the system transferred it to you.
Held by CAROL	Carol held a call too long, so the system transferred the call to you.
Line001 callback CALLBACK	A call on line 001 was camped, parked, or transferred, but no one answered it. Press CALLBACK or the line button to connect to the call.
Line001 to prime	There is no telephone that can receive a call on line 001, so the system transferred it to you.
Line007>BRENDA	A call on line 007 was forwarded or routed to Brenda, but was not answered.
Line007 Line121	The call coming in on line 007 was routed to target line 121. Line 121 is busy so the system transferred the call to you.

Handling calls

Answering many calls

Sometimes calls come in faster than you can answer them. When you have several calls ringing, use Call Queuing to answer the next call.

1. Enter the Call Queuing feature code (Feature 8 0 1).

If more than one call is waiting, priority is given to incoming external calls over callback, camped, or transferred calls.

Leaving a message for a co-worker

You can use Norstar's Message feature to leave someone a message to call you.

1. Enter the Message feature code (Feature 1).
2. Press **ADD**. (This step is not necessary on a telephone with a one-line display.)
3. Dial the internal number of the person you want to send a message to.

That person's telephone displays **Message for you**.

Transferring a call

When you want to transfer a call to someone:

1. Press **TRANSFER**.
2. Dial the number of the person you want to transfer the call to.
3. If you want to speak to the person first, wait for them to answer.
4. Press **JOIN**.

Transferring a call when a telephone is busy

When a telephone is busy, or when transfer is denied, you can use Camp-on to transfer a call.

1. Enter the Camp-on feature code (Feature 8 2).
2. Dial the internal number of the person you want to transfer the call to.

The person is notified that they have a camped call waiting.

Transferring a call to a co-worker who is not at their desk

If a person is not at their desk, but it's important that you get a call to them, you can park the call and announce it using Page.

1. Enter the Call Park feature code (Feature 7 4). The display shows the retrieval code.
2. Press **PAGE**.
3. Select the appropriate type of page. Your system coordinator can explain the different types to you.
4. Page the person and ask them to answer the call using the retrieval code.

The person can retrieve the call from any Norstar telephone.

Interrupting a co-worker's current call

If your co-worker is on a call and a second important call comes in, you can interrupt their current call.

1. Dial the number of your co-worker. The display reads **On another call**.
2. Enter the Priority Call feature code. (Feature).

After a pause, your call goes through. Your co-worker can stop your priority call from going through, using the Do Not Disturb feature code. (Some prime telephones may not support this feature. See your system coordinator.)

Monitoring the status of someone's telephone

If you have an autodial button or an answer button with an indicator programmed for someone's telephone, you can monitor the status of their telephone by watching the indicator next to their button. You can also use Ring Again to tell you when a busy or unanswered telephone becomes available.

1. Dial the number of the person you want to speak to. You will hear either ringing, or a busy signal.
2. Press **LATER**. The display reads **Ring Again?**.
3. Press **YES**.

When the person hangs up or next uses their telephone, your telephone rings and the display asks if you want to call the person. Press **YES** to call them.

Making sure calls are answered when you are away from your desk

When you are away from your desk, you can make sure calls get answered by forwarding your calls to someone else.

1. Enter the Call Forward feature code (Feature).
2. Dial the number of the person who will be answering your calls.

Your calls now ring at that person's telephone.

To cancel Call Forward:

1. Enter the Cancel Call Forward feature code (Feature).

A more sophisticated way to provide alternate answering while you are away is to invoke a Service Mode. Ask your system coordinator for more information on Service Modes.

Providing backup answering for internal calls

In addition to providing backup answering for external calls, you can provide backup answering for people's internal calls using Call Forward. Individuals can forward all their calls to you. Your system can also be programmed so that you answer all calls to telephones that are busy or do not answer. See your system coordinator for information on Call Forward Busy and Call Forward No Answer.

Personalizing your telephone

Programming memory buttons for frequently used features

You can program memory buttons for one-touch access to features that you use often like Transfer, Message, and Ring Again.

1. Press **Feature** * **3**.
2. Press the button you want to program.
3. Press **Feature** and enter the feature code you want to program.
4. Label the button.

You can now use the feature by simply pressing the programmed button. You cannot program line, incoming line group, intercom, answer, or Handsfree/Mute buttons.

Programming memory buttons for frequently called numbers

You can program memory buttons for one-touch access to numbers that you call often.

1. Press **Feature** * **1** to program an external number or **Feature** * **2** to program an internal number.
2. Press the button you want to program.
3. For external numbers, if you want this autodial button to use a particular line or line pool, select that line or line pool.
4. Enter the number you want to program.
5. For external numbers, press **Hold** or **OK** when finished.
6. Label the button.

You can now call the person by simply pressing the programmed button. You cannot program line, incoming line group, intercom, answer, or Handsfree/Mute buttons.

Moving line buttons

You can arrange the buttons on your telephone to suit your needs.

1. Press **Feature** * **8** **1**.
2. Press the line button you want to move.
3. Press the button you want to move that line to.
The buttons are exchanged.
4. Press **Ris**.
5. Exchange the button caps.

You cannot choose a button other than a line or incoming line group button as the button to move in step 2. You cannot exchange a line button with an answer, intercom or Handsfree/Mute button.

Your Norstar M7100 telephone

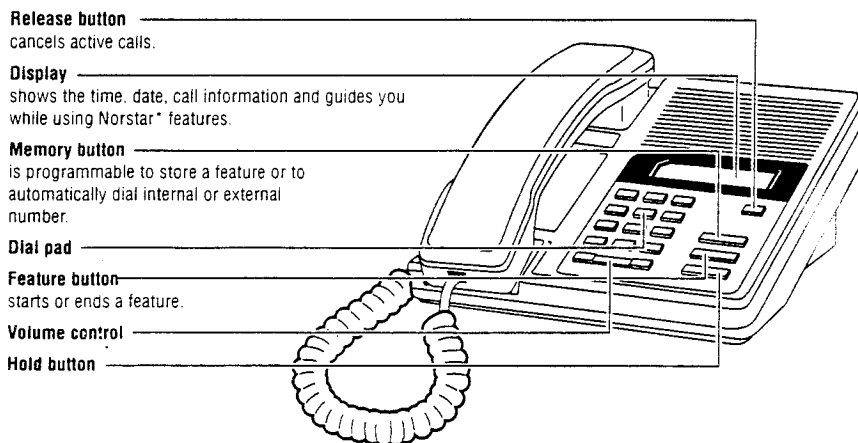

Button inquiry

Confirm that your memory button has the correct snap-on cap by checking its programming.

1. Release all calls and open lines with dial tone.
2. Press **[Feature] * 0**.
3. Read the display.
4. Press **[Feature]** when finished.

Adjusting display contrast

1. Press **[Feature] * 1**.
2. Press **[1] to [9]** for the level you want.

Selecting a ring type and volume

1. Press **[Feature] 6**.
2. Press **[1], [2], [3]** or **[4]** to hear the different types of rings.
3. While the telephone is ringing, press **[<] [>]** to adjust the volume.
4. Press **[Feature]** to store the ring.

Adjusting receiver or telephone speaker volume

1. Press **[<] [>]** when using the receiver or the speaker.

Important: All M7100 telephones Release 09 (REL 09) and higher comply with the Americans with Disabilities Act (ADA). See the label on the bottom of the telephone for the Release marking.

* Meridian and Norstar are trademarks of Northern Telecom

Making calls

Internal calls

1. Pick up the receiver.
2. Dial the internal number.

External calls

1. Pick up the receiver.
2. Dial (or your system's external line access code).
3. Dial the external telephone number.

Note: Internal numbers and the external access code are supplied by your system coordinator.

Making and answering a second call

The M7100 telephone allows you to have two calls active at the same time. By using you can switch between calls.

To answer a second call while on another call

1. Press to put the first call on hold.
The second call automatically comes onto the line.

To hold a call and make a second call

1. Press to put the first call on hold.
2. Dial the telephone number for the second call.

To return to the first call

1. Press again to return to the first call on hold.
The second call is automatically put on hold.

To hold a call

1. Press .
2. Press again to return to the call on hold.
Check the display for confirmation or additional information.

Programming the memory button

About the memory button

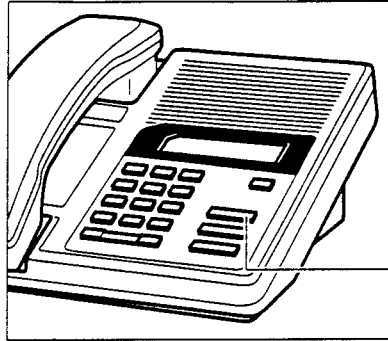

The memory button can store a telephone number or feature code to give you one touch dialing or feature activation. You can change the memory button by programming it with a new number or feature code.

Memory button

Remember: Press * to check the memory button.

Programming memory buttons

External autodial

1. If you are on a call or an open line with dial tone, press or .
2. Press * .
3. Dial the external number.
4. Press to store the number.
5. Label your new button.

Internal autodial

1. If you are on a call or an open line with dial tone, press or .
2. Press * .
3. Dial the internal number.
4. Label your new button.

Features

1. If you are on a call or an open line with dial tone, press or .
2. Press * .
3. Press and the feature code.
4. Label your new button.

Erasing memory buttons

1. If you are on a call or an open line with dial tone, press or .
2. Press * .
3. Press to erase the button.

Your Norstar M7208 telephone

Display

shows the time, date, call information and guides you while using Norstar* features.

Indicators

appear beside active lines and features.

Feature button

starts or ends a feature.

Release button

cancels active calls.

Hold button

Dial pad

Volume control

Memory and line buttons

are buttons with indicators for one touch dialing, feature operation or line access.

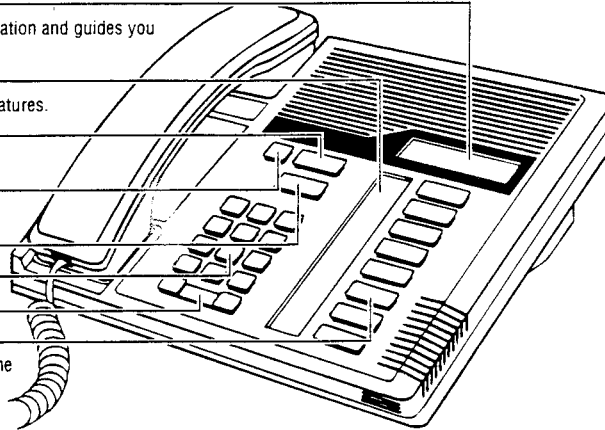

Button Inquiry

Confirm that your memory and line buttons have the correct snap-on caps by checking their programming.

1. Release all calls and open lines with dial tone.
2. Press **Feature** * **0**.
3. Press the button you want to check.
4. Read the display.
5. Press **Feature** when finished.

Adjusting display contrast

1. Press **Feature** * **7**.
2. Press a number on the dial pad for the contrast level you want; the higher the number the higher the contrast level.

Selecting a Ring Type and volume level

1. Press **Feature** * **6**.
2. Press **1**, **2**, **3** or **4** to hear the different types of rings.
3. While the telephone is ringing, press **Left Arrow** **Right Arrow** to adjust the volume.
4. Press **Feature** to store the ring.

Adjusting receiver or telephone speaker volume

1. Press **Left Arrow** **Right Arrow** when using the receiver or the speaker.

Important: All M7208 telephones Release 16 (REL 16) and higher comply with the Americans with Disabilities Act (ADA). See the label on the bottom of the telephone for the Release marking.

* Meridian and Norstar are trademarks of Northern Telecom.

Making calls

About line buttons

Norstar systems can have different types of line buttons. Match the line buttons on your telephone with the ones below for instructions on how to use them.

Intercom
Line 1

Internal calls using Intercom buttons **External calls using numbered Line buttons**

- | | |
|--|--|
| <ol style="list-style-type: none"> 1. Pick up the receiver. 2. If ► appears beside an Intercom button, then dial. <p>OR</p> <p>Press an Intercom button without ►, then dial.</p> | <ol style="list-style-type: none"> 1. Pick up the receiver. 2. When ► appears beside a numbered Line button, then dial. <p>OR</p> <p>Press a numbered Line button without ►, then dial.</p> |
|--|--|

Note: Internal numbers are supplied by your system coordinator.

4321

Internal calls using extension buttons

1. Pick up the receiver.
2. When ► appears beside an extension button, then dial.

External calls using extension buttons

1. Pick up the receiver.
2. When ► appears beside the extension button, dial 9 (or your system's external line access code) and the number.

Hold

Holding Calls

1. Press . The ► flashes beside the line on hold.
2. Press the line button with the flashing ► to return to the call.

Check the display for confirmation or additional information.

Automatic hold

Calls are put on hold automatically when you switch from one line to another.

Handsfree

This button operates the telephone's built-in microphone and speaker in place of the receiver. Your system coordinator can program Handsfree to your telephone.

Making calls

1. Press instead of picking up the receiver.

Switching between Handsfree and handset

1. Press and replace the handset to switch to Handsfree.
2. Pick up the receiver to switch back.

Using Mute

1. Press to turn the microphone OFF.
2. Press again to turn the microphone ON.

Dialing without lifting the handset

1. Press a line button without ►, then dial your call.
2. When answered, pick up the receiver, or press .
3. If the call is not answered, or the line is busy, press .

Programming memory buttons

About the memory buttons

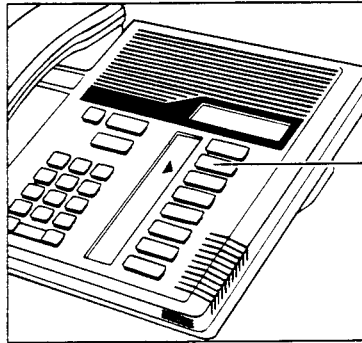

Memory buttons are the buttons with indicators other than line or Handsfree buttons. Memory buttons store telephone numbers or feature codes to give you one touch dialing or feature activation. You can change what a memory button does by just programming it with a new number or feature. You cannot program a line or Handsfree button.

Remember: Press * to check a memory or line button.

Programming memory buttons

External autodial

1. If you are on a call or an open line with dial tone, press Or .
2. Press * .
3. Press a memory button.
4. Dial the external number.
5. Press to store the number.
6. Label your new button.

Internal autodial

1. If you are on a call or an open line with dial tone, press Or .
2. Press * .
3. Press a memory button.
4. Dial the internal number.
5. Label your new button.

Features

1. If you are on a call or an open line with dial tone, press Or .
2. Press * .
3. Press a memory button.
4. Press and the feature code.
5. Label your new button.

Erasing memory buttons

1. If you are on a call or an open line with dial tone, press Or .
2. Press * .
3. Press the memory button you want to erase.
4. Press to erase the button.

Your Norstar M7310 telephone

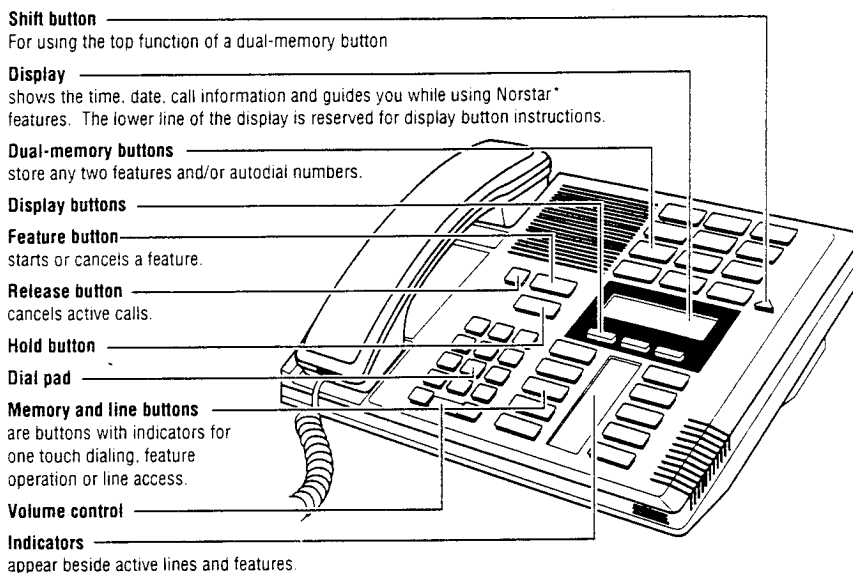

Using display buttons

Display buttons change with each feature you use. The labels for display buttons appear in capital letters directly above them on the second line of the display. A display button with an "OK" label above it is represented as **OK** in this card.



Button inquiry

Confirm that your memory and line buttons have the correct snap-on caps by checking their programming.

1. Release all calls or open lines with dial tone.
2. Press **Feature** * **0**.
3. Press the button(s) you want to check and read the display.
4. Press **Feature** when finished.

Adjusting display contrast

1. Press **Feature** * **7**.
2. Press **UP** or **DOWN** for the level you want.
3. Press **OK** when finished.

Selecting a ring type and volume level

1. Press **Feature** * **6**.
2. Press **1**, **2**, **3** or **4** to hear the different types of rings.
3. While the telephone is ringing, press **Left Arrow** or **Right Arrow** to adjust the volume.
4. Press **OK** to store the ring.

Important: All M7310 telephones Release 16(REL 16) and higher comply with the Americans with Disabilities Act (ADA). See the label on the bottom of the telephone for the Release marking.

* Meridian and Norstar are trademarks of Northern Telecom

Making calls

About line buttons

Norstar systems can have different types of line buttons. Match the line buttons on your telephone with the ones below for instructions on how to use them.

Intercom
Line 1

Internal calls using intercom buttons

1. Pick up the receiver.
2. If ► appears beside an intercom button, then dial.
OR
Press an intercom button without ►, then dial.

External calls using numbered line buttons

1. Pick up the receiver.
2. When ► appears beside a numbered line button, then dial.
OR
Press a numbered line button without ►, then dial.

Note: Internal numbers are supplied by your system coordinator.

4321

Internal calls using extension buttons

1. Pick up the receiver.
2. When ► appears beside an extension button, then dial.

External calls using extension buttons

1. Pick up the receiver.
2. When ► appears beside the extension button, then dial 9 (or your system's external line access code) and the number.

Hold

Holding Calls

1. Press **Hold**. The ► flashes beside the line on hold.
2. Press the line button with the flashing ► to return to the call.
Check the display for confirmation or additional information.

Automatic hold

Calls are put on hold automatically when you switch from one line to another.

Handsfree
Mute

This button operates the telephone's built-in microphone and speaker in place of the receiver. Your system coordinator can program Handsfree to your telephone.

Making calls

1. Press **Handsfree** instead of picking up the receiver.

Switching between Handsfree and handset

1. Press **Handsfree** and replace the handset to switch to Handsfree.
2. Pick up the receiver to switch back.

Using Mute

1. Press **Handsfree** to turn the microphone OFF.
2. Press **Handsfree** again to turn the microphone ON.

Dialing without lifting the handset

1. Press a line button without ►, then dial your call.
2. When answered, pick up the receiver, or press **Handsfree**.
3. If the call is not answered, or the line is busy, press **Ris**.

Programming memory buttons

About memory buttons

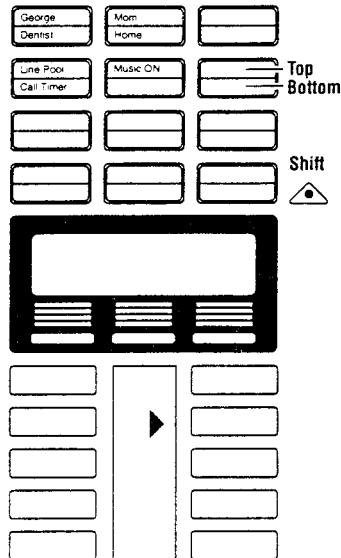

There are two types of memory buttons: single-memory and dual-memory. Memory buttons store telephone numbers or feature codes to give you one touch dialing or feature activation.

Dual-memory buttons

To use the **bottom** function, press the dual-memory button. To use the top function, press the shift button, then press the dual-memory button.

Single-memory buttons

Single-memory buttons are the buttons with indicators other than line or Handsfree buttons.

Remember: Press [Feature] * 0 to check a memory or line button.

Programming memory buttons

External autodial

1. If you are on a call or an open line with dial tone, press [Hold] or [Ris].
2. Press [Feature] * 1.
3. Press a memory button.
4. Dial the external number.
5. Press **OK** to store the number.
6. Label your new button.

Internal autodial

1. If you are on a call or an open line with dial tone, press [Hold] or [Ris].
2. Press [Feature] * 2.
3. Press a memory button.
4. Dial the internal number.
5. Label your new button.

Features

1. If you are on a call or an open line with dial tone, press [Hold] or [Ris].
2. Press [Feature] * 3.
3. Press a memory button.
4. Press [Feature] and the feature code.
5. Label your new button.

Erasing memory buttons

1. If you are on a call or an open line with dial tone, press [Hold] or [Ris].
2. Press [Feature] * 1.
3. Press the memory button you want to erase.
4. Press **OK** to erase the button.

Your Norstar M7324 telephone

Memory and line buttons

are buttons with indicators for one touch dialing, feature operation or line access.

Display

shows the time, date, call information and guides you while using Norstar® features. The lower line of the display is reserved for display button instructions.

Display buttons

Dial pad

Volume control

Feature button

starts or cancels a feature.

Hold button

Release button

cancels active calls.

Indicators

appear beside active lines and features.

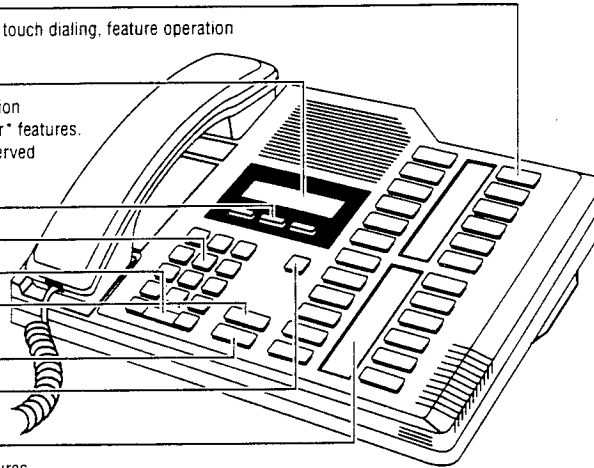

Using display buttons

Display buttons change with each feature you use. The labels for display buttons appear in capital letters directly above them on the second line of the display. A display button with an "OK" label above it is represented as **OK** in this card.

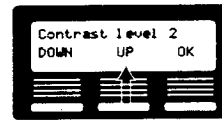

Button inquiry

Confirm that your memory and line buttons have the correct snap-on caps by checking their programming.

1. Release all calls or open lines with dial tone.
2. Press **[Feature] * 0**.
3. Press the button(s) you want to check and read the display.
4. Press **[Feature]** when finished.

Adjusting display contrast

1. Press **[Feature] * 7**.
2. Press **UP** or **DOWN** for the level you want.
3. Press **OK** when finished.

Selecting a ring type and volume level

1. Press **[Feature] * 6**.
2. Press **1**, **2**, **3** or **4** to hear the different types of rings.
3. While the telephone is ringing, press **[Left Arrow]** or **[Right Arrow]** to adjust the volume.
4. Press **OK** to store the ring.

Important: All M7324 telephones Release 10 (REL 10) and higher comply with the Americans with Disabilities Act (ADA). See the label on the bottom of the telephone for the Release marking.

* Meridian and Norstar are trademarks of Northern Telecom.

Making calls

About line buttons

Norstar systems can have different types of line buttons. Match the line buttons on your telephone with the ones below for instructions on how to use them.

Intercom

Line 1

Internal calls using intercom buttons

1. Pick up the receiver.
2. If ► appears beside an intercom button, then dial.
OR
Press an intercom button without ►, then dial.

External calls using numbered line buttons

1. Pick up the receiver.
2. When ► appears beside a numbered line button, then dial.
OR
Press a numbered line button without ►, then dial.

Note: Internal numbers are supplied by your system coordinator.

4321

Internal calls using extension buttons

1. Pick up the receiver.
2. When ► appears beside an extension button, then dial.

External calls using extension buttons

1. Pick up the receiver.
2. When ► appears beside the extension button, then dial 9 (or your system's external line access code) and the number.

Hold

Holding Calls

1. Press Hold. The ► flashes beside the line on hold.
2. Press the line button with the flashing ► to return to the call.
Check the display for confirmation or additional information.

Automatic hold

Calls are put on hold automatically when you switch from one line to another.

Handsfree

This button operates the telephone's built-in microphone and speaker in place of the receiver. Your system coordinator can program Handsfree to your telephone.

Making calls

1. Press Handsfree instead of picking up the receiver.

Switching between Handsfree and handset

1. Press Handsfree and replace the handset to switch to Handsfree.
2. Pick up the receiver to switch back.

Using Mute

1. Press Handsfree to turn the microphone OFF.
2. Press Handsfree again to turn the microphone ON.

Dialing without lifting the handset

1. Press a line button without ►, then dial your call.
2. When answered, pick up the receiver, or press Handsfree.
3. If the call is not answered, or the line is busy, press Rls.

Programming memory buttons

About memory buttons

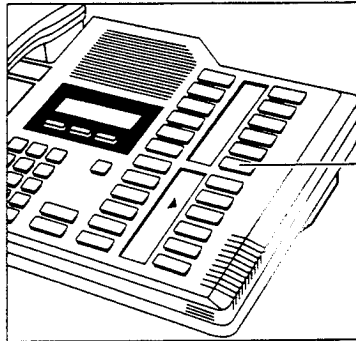

Memory buttons are the buttons with indicators other than line or Handsfree buttons. Memory buttons store telephone numbers or feature codes to give you one touch dialing or feature activation. You can change what a memory button does by just programming it with a new number or feature.

If you have programmed a memory button with an internal number the indicator comes on when the number is busy.

Remember: Press * to check a memory or line button.

Programming memory buttons

External autodial

1. If you are on a call or an open line with dial tone, press or .
2. Press * .
3. Press a memory button.
4. Dial the external number.
5. Press **OK** to store the number.
6. Label your new button.

Internal autodial

1. If you are on a call or an open line with dial tone, press or .
2. Press * .
3. Press a memory button.
4. Dial the internal number.
5. Label your new button.

Features

1. If you are on a call or an open line with dial tone, press or .
2. Press * .
3. Press a memory button.
4. Press and the feature code.
5. Label your new button.

Erasing memory buttons

1. If you are on a call or an open line with dial tone, press or .
2. Press * .
3. Press the memory button you want to erase.
4. Press **OK** to erase the button.

Glossary

A

Access code: A sequence of characters used to gain entry into any type of Norstar system programming.

Administration: A programming section that lets you assign and maintain certain settings on the Norstar system. Administration programming is performed by the system coordinator.

Administration access code: To access Administration programming, press

Feature * * A D M I N .

You will be asked for an Administration password.

Administration password: A one-to six-digit password that prevents unauthorized access to Administration programming. The Administration password can be assigned and changed in Administration programming.

Alarm code: A number that appears on the alarm telephone's display, informing you that the KSU has detected a fault in the system.

Alarm telephone: A telephone that is designated to receive reports of Norstar system problems. This function is usually assigned to a prime telephone. The alarm telephone is assigned by the installer or customer service representative.

Allow Redirect: A sub-heading in Administration programming that allows you to set whether Line Redirection can be used from that telephone.

Analog Terminal Adapter (ATA): A device that permits the connection of analog telecommunication devices such as fax machines, answering machines, and single line telephones to the Norstar system. Programmed defaults for the ATA are automatically assigned by the Norstar system.

Answer button: A telephone button with an indicator that is used to monitor another telephone. The answer button indicates incoming calls destined for the other telephone. Someone working at a telephone with answer buttons (an attendant, for example) can receive all ringing and visual indication of incoming calls for other telephones, and answer those calls when necessary.

One telephone can have up to four answer buttons. An answer button is automatically assigned to a telephone when that telephone is assigned an answer DN.

Answer DN: A directory number (DN) of a telephone that is monitored by an answer button. Up to four answer DNs can be assigned to a telephone by the customer service representative.

Autobumping: A feature that determines what the system does with new Call Log items when your Call Log is full. When Autobumping is on, a new log entry causes the oldest entry to be deleted. If Autobumping is off, your Norstar system does not log calls when your log is full.

Autodial button: A memory button that, if programmed, provides one-touch dialing of external or internal numbers.

Autolog options: A feature that allows you to select the type of calls that are stored in your Call Log. You can choose to log calls that were not answered by anyone within the system, to log calls that were unanswered at this telephone but answered elsewhere in the system, to log all calls answered and not answered at this telephone, or to not have calls automatically logged.

Automatic Dial: A feature that allows you to dial without having to pick up the receiver or select a line. You must have a prime line to use Automatic Dial.

Automatic Handsfree: A feature that automatically activates Handsfree operation when you make or answer a call. Automatic Handsfree is assigned in Administration programming.

Automatic Hold: A feature that automatically places an active call on hold when you select another line. Automatic Hold is programmed by your customer service representative.

Automatic Privacy: See Privacy.

Automatic Telephone Relocation: A feature that lets a telephone retain its personal and system programming when it is plugged into a different Norstar modular jack. Automatic Telephone Relocation is enabled by your customer service representative.

Auxiliary ringer: A separate external telephone ringer or bell that can be programmed to ring when a line or a telephone rings. An auxiliary ringer may be programmed to ring only when the system is in a particular service mode. Programming of an auxiliary ringer is done in Administration programming after the feature has been enabled by your customer service representative.

B

Background Music: A feature that lets you hear music from the speaker of your Norstar telephone. It is available only if a music source has been attached to the KSU and the feature has been enabled by your customer service representative.

Busy Lamp Field (BLF): A device with a liquid crystal display (LCD) panel of indicators that shows the status of up to 24 telephones in the Norstar system. The BLF shows a telephone as busy if it is active on a call, has Do Not Disturb turned on, or is being used for programming. The BLF attaches to the M7310 telephone.

Button caps: Interchangeable plastic caps that fit over the buttons of Norstar telephones. They are used to indicate the features programmed onto each programmable memory button. Button caps are either preprinted or have clear windows that allow you to label the buttons.

Button Inquiry: A feature that allows you to check the function of each programmable button on your Norstar telephone.

Bypass Restrictions: A setting that allows you to override any Call Restrictions applied to specific System Speed Dial numbers. Bypass Restrictions can be turned on in Administration programming.

C

Call Duration timer: A feature that lets you see how long you spent on your last call or how long you have been on your present call.

Call Forward: A feature that forwards all the calls arriving at your telephone to another telephone in your Norstar system. To have calls forwarded outside the system, use Line Redirection.

Call Forward No Answer: A feature that forwards all calls arriving at your telephone to another designated telephone in your Norstar system after a specific number of rings. Call Forward No Answer is assigned in Administration programming.

Call Forward On Busy: A feature that forwards all calls at your telephone to another designated telephone if your telephone is busy. This feature is assigned in Administration programming.

Call Information: A feature that allows you to display information about incoming calls. For external calls, you can display the caller's name, telephone number and the line name. For an internal call, you can display the name of the caller and their internal number. You can obtain information about ringing, answered, or held calls.

Call Log: Enter your Call Log to view a record of incoming calls. The log could contain the following information for each call: sequence number in the Call Log, name and number of caller, long distance indication, indication if the call was answered, time and date of the call, number of repeated calls from the same source, and name of the line that the call came in on. See Autobumping, Autolog options, and Logit for further information.

Call Park: A feature that allows you to place a call on hold so that someone can retrieve it from any other telephone in the Norstar system by selecting an internal line and entering a retrieval code. The retrieval code appears on the display of your telephone when you park the call. You can park up to nine calls on the system at one time.

Call Park Callback: See Callback.

Call Park prefix: The first digit of the retrieval code of a parked call. This digit cannot conflict with the first digit of any existing DNs, Line Pool access codes, the Direct-dial digit, or the external line access code. The default Call Park prefix digit is "1". It may be set to none, in which case Call Park is disabled. Call Park prefix is assigned by your customer service representative.

Call Pickup Directed: A feature that lets you answer a call ringing at any Norstar telephone by entering the internal number of that telephone before taking the call. Call Pickup Directed is activated by your customer service representative.

Call Pickup Group: See Pickup Group.

Call Queuing: A feature that allows you to answer calls in order of priority if you have several calls waiting at your telephone. Priority is given to external incoming calls, followed by callback and camped calls.

Callback: A feature that returns parked, camped or transferred calls to your telephone if they are not answered at another telephone. How long the system will wait before Callback occurs is set by your customer service representative.

Camp-on: A feature that lets you reroute a call to a telephone even if all the lines on that telephone are busy. To answer a camped call, use Call Queuing or select a line if the camped call appears on your telephone. Priority is given to queued calls over camped calls.

Camp timeout: The length of a delay before a camped call is returned to the telephone that camped the call. This delay is set by your customer service representative.

Capabilities: A section heading in Administration programming, that covers the dialing filters, remote access packages, set abilities, and line abilities that can be assigned to Norstar lines, telephones, or Class of Service passwords.

Central answering position (CAP): An M7324 telephone that has been designated a CAP by your installer or customer service representative. The CAP provides backup answering and can be used to monitor the telephones within a Norstar system. One or two CAP modules can be attached to a CAP to increase the number of lines it can handle.

Central answering position (CAP) module: A module connected to an M7324 telephone that provides 48 additional buttons that can be used as autodial buttons or feature buttons. A maximum of two CAP modules can be connected to a single M7324 telephone.

Class of Service (COS): The set of Norstar features and lines available to the user. The Class of Service for a call is determined by the dialing filters and remote access packages assigned to the telephone in Administration programming. The Class of Service for a call can be changed by entering a six-digit Class of Service password. (Internal users cannot change their access to features with a COS password, only their dialing filters.) Class of Service and Class of Service passwords are assigned in Administration programming. See Remote Access.

Class of Service password: A six-digit code that lets you switch from your current Class of Service to one that lets you dial numbers prohibited by your current Class of Service.

Conference: A feature that allows you to establish a three-person call at your Norstar telephone.

Conference using privacy: A feature that allows you to turn privacy off for a call allowing another person with the same line to press the line button and join in your conversation, forming a conference. Normally your calls are private; no one else can pick up your line and join in.

Contrast Adjustment: A feature that allows you to set the contrast level of your telephone display.

Control telephone: A telephone that can place the lines and telephones for which it has responsibility in or out of a Service Mode. A telephone is programmed as a control telephone and has lines and telephones assigned to it in Administration programming.

COS: See Class of Service.

Cursor: A short horizontal line that appears on the Norstar telephone display to indicate that characters can be entered using the dial pad.

D

Data Communications Interface (DCI): A Norstar device that lets you attach an RS-232 data device to your Norstar system.

Data terminal: A device, such as a modem, that can be used to transfer data instead of sound over a telephone network. You cannot use Norstar programming to set up such devices. See the documentation that accompanies the device.

Date: See Show Time or Time and Date.

Defaults: The settings for all Norstar features when the system is first installed. Settings are changed from their defaults in Administration programming and by your customer service representative. In this manual, default settings are shown in **bold** text.

Delayed Ring Transfer (DRT) to Prime: A feature that transfers an unanswered call on an external line to the prime telephone associated with that line after a specified number of rings. This feature is activated by your customer service representative.

Destination code: A number that looks like a Norstar internal number, but is translated by the system to dial an external telephone number. This allows transparent dialing in a network. These numbers are programmed by your customer service representative.

Dial mode: The dialing mode of a line can be either tone or pulse. Pulse is traditionally used by rotary dial telephones. Tone is also referred to as dual-tone multifrequency (DTMF) tones. Dial mode can be programmed by your customer service representative.

Dialing filter: A feature that prevents certain telephone numbers or feature codes from being dialed through a combination of restrictions and exceptions. Dialing filters can be applied to lines (line filters, remote filters), to telephones (set filters), to specific lines on a telephone (line/set filters), and to Class of Service passwords (user filters, remote filters). Different line, set, and remote filters can also be applied for each of six Service Modes. The Norstar Modular system can handle up to 100 dialing filters.

Direct inward system access (DISA): A feature that lets remote users dial directly into the Norstar system and use Norstar features. Callers hear stuttered dial tone and are required to enter a Class of Service password to gain access to the system. See Remote Access.

Direct-dial: A feature that lets you dial a designated telephone inside or outside your Norstar system with a single digit. As many as five Direct-dial telephones can be established. Each telephone in the system is assigned to one Direct-dial telephone. There is a single, system wide digit for calling the assigned Direct-dial telephone of any telephone. Direct-dial telephones are established in Administration programming. Telephones are assigned to a Direct-dial telephone in Administration programming.

Direct-dial number: A digit used system wide to call a Direct-dial telephone. The digit is programmed by your customer service representative.

Direct-dial #: A digit used system-wide to call a direct dial telephone. The digit is assigned by your installer or customer service representative.

Directed Pickup: See Call Pickup Directed.

Directory number (DN): A unique number that is automatically assigned to each telephone or data terminal. The DN, also referred to as an internal number, is often used to identify a telephone when settings are assigned during programming. Default DN assignments start at 21 in a two-digit (non-expanded) system and 221 in a three-digit (expanded) system.

DISA: See Direct inward system access.

DISA DN: A received number assigned to the Norstar direct inward system access facility. If a caller dials a number that is assigned to the DISA DN, the caller hears stuttered dial tone and must enter a Class of Service password. Once the password is accepted, the caller hears system dial tone and can use remote access features. See Remote access.

Display: A liquid crystal display (LCD) on the Norstar telephone that guides you through feature operation and programming.

Display button: One of three buttons located directly beneath the display on M7310 and M7324 telephones. During feature operation or programming, some or all of these buttons may be used to provide further options. If an option is available, it is shown in the bottom line of the two-line display, directly above the corresponding display button. Display buttons are represented in this manual as underlined capitals, e.g. OK.

Display digits: A subheading in Administration programming that allows you set whether an assigned name or the actual number is displayed when someone uses a system speed dial code.

DN: See Directory number.

DRT delay: The number of rings before a Delayed Ring Transfer occurs. This is assigned by your customer service representative.

DRT to prime: See Delayed Ring Transfer to prime.

E

Emergency telephone: A single-line telephone (also referred to as a 500/2500 telephone) that becomes active when there is no power to the Key Service Unit.

Event message: An item stored in the system log and displayed during a Maintenance session. Event messages record a variety of events and activities in the Norstar system.

Exceptions: A component of a dialing filter. Exceptions are numbers you can dial even if they are forbidden by a more general Restriction. See Restrictions.

External call: A call to a destination outside the Norstar system.

External Call Forward: See Line Redirection.

External code: The number you dial to get an external line. The default is 9, but this can be changed by your customer service representative. You do not always need an external code. It is primarily to support the M7100 telephone and single-line telephones using an Analog Terminal Adapter (ATA).

External line: A line on your Norstar telephone used for making calls to destinations outside the Norstar system.

External music source: See Music source.

External paging: A feature you can use to make voice announcements over an externally-mounted loudspeaker connected to the Key Service Unit. The external speaker is not a Norstar component and must be supplied by the customer.

Extra-dial telephone: A heading in Administration programming that allows you to assign an extra direct-dial telephone when a service mode is active. You can have one extra-dial telephone for Ringing service in each of the six service modes.

F

Feature button: A button that activates many Norstar features when it is pressed and followed by a feature code. The Feature button is also used to exit a feature.

Feature code: A number that is used to activate a particular feature.

Forward: See Call Forward.

Forward delay: The number of rings before an unanswered call is forwarded to another telephone when the Call Forward No Answer feature is on. Forward delay is assigned in Administration programming.

Forward No Answer: See Call Forward No Answer.

Forward On Busy: See Call Forward On Busy.

Full Autohold (on idle line): A feature that, when activated, puts a line on hold when you select an available line and then do something that selects another line. Full Autohold is activated by your customer service representative.

Full Handsfree: See Handsfree.

G

Group Listening: A feature that allows you to have others in your office hear a caller through your phone's speaker. The caller hears you only when you speak into the receiver and cannot hear other people in the office.

H

Handsfree: A feature you can use to make calls without using the telephone receiver. Full Handsfree is activated in Administration programming. When it is activated, a Handsfree/Mute button is automatically assigned to the telephone.

Handsfree (HF) Answerback: A feature that automatically turns on the microphone at a telephone receiving a Voice Call so that the person receiving the call can respond without lifting the receiver. Handsfree Answerback is activated in Administration programming.

Handsfree/Mute button: See Handsfree.

Headset: A head-mounted or ear-mounted telephone receiver that is used instead of the hand-held receiver. Headsets are not Norstar components and must be supplied by the customer.

Held (Line) Reminder: An indication that an external call has been placed on hold for a certain period of time. Your Norstar telephone rings and displays the message **On hold: LINENAM**, where **LINENAM** is the name of the line held the longest. The Held Line Reminder feature and Remind delay are programmed by your customer service representative.

HF Answerback: See Handsfree Answerback.

Hold button: A button used to suspend calls so that the person using the telephone can perform another task without disconnecting the caller.

Hookswitch Flash: See Link time.

Host system signaling: (Also referred to as end-to-end signaling.) Norstar telephones can access a remote system or dial a number on an alternate carrier by means of host feature activation, such as Link, Pause and Run/Stop.

Hotline: A feature that automatically calls a preassigned number when the telephone's receiver is lifted or the Handsfree/Mute button is pressed. A Hotline number can be an internal or external number. Hotline is programmed in Administration programming.

I

I/C: An abbreviation of intercom.

Incoming line group: A group of lines used for incoming calls. Incoming line groups provide a way of giving a telephone access to several incoming lines without taking up many line buttons. A line is assigned to be part of an incoming line group by your installer or customer service representative.

Installer: A person who installs the Norstar equipment, and performs initial system programming. The Installer or the system coordinator can program Administration settings.

Intercom button: A button that provides access to internal lines used for calls within a Norstar system and access to external lines through a line pool or external code. A telephone may be assigned zero to eight Intercom buttons. This is done by the customer service representative.

Internal line: A line on your telephone dedicated to making calls to destinations inside your Norstar system. An internal line may still connect you with an external caller if you use it to access a line pool or to pick up a call using Norstar call handling features such as Call Park or Call Pickup Directed.

Internal number: A number (also referred to as a directory number or DN) that identifies a Norstar telephone or device.

Internal user: A person using a Norstar telephone within a Norstar system.

K

Key Service Unit (KSU): The central hardware component in the Norstar system. The KSU has its own processor and memory, and provides a physical point of connection for the various types of devices, telephones, and expansion modules used in Norstar. The KSU can function on its own as a basic system (with 32 Norstar telephones and up to 48 external lines), or with the addition of a Trunk Module (TM) that supports more external lines, or a Station Module (SM) that supports more Norstar telephones.

L

Last Number Redial: A feature that allows you to redial the last external number you dialed.

Least cost routing: See Routing.

Line: The complete path of a voice or data connection between one telephone (or other device) and another.

Line abilities: The heading in Administration programming under which you assign Line Filters, Remote Filters, and Remote Access Packages to lines.

Line filter: See Dialing filter.

Line names: The subheading in Administration programming that allows you to assign names to external lines.

Line number: A number that identifies an external line. The total number of lines depends on how many Trunk Modules are installed.

Line pool: A group of lines used for making external calls. Line pools provide an efficient way of giving a telephone access to external lines without taking up many line buttons. A line is assigned to be a member of a line pool by your customer service representative.

Line Pool access code: A number that identifies a line pool. Line pool access codes are assigned by your customer service representative.

Line Profile: A feature you can use to review the settings programmed to lines by the customer service representative and by Administration programming. The settings cannot be changed with this feature. Line profile is available only on M7310 and M7324 telephones.

Line Redirection: A feature that allows you to redirect all calls on an incoming line to a destination outside the Norstar system. Once a line is redirected it cannot be answered within the Norstar system. The system may be set up to give a brief ring when a call comes in on a redirected line. This feature differs from Call Forward in two ways. It redirects only external calls (not internal calls) and it redirects calls to destinations outside the system. Call forward redirects calls only to destinations inside the Norstar system. See Call Forward and Redirect Ring.

Link: If your Norstar system is connected to a Private Branch Exchange (PBX), you can use a Link signal to access special features. The Link signal can also be included as part of a longer stored sequence on an External Autodial button or in a Speed Dial code. The Link symbol (☎) uses two of the 24 spaces in a dialing sequence.

Link time: A specific time delay that allows access to PBX features through a Norstar system. Link time is also referred to as a Hookswitch Flash or Recall. Link time is assigned by your customer service representative.

Logit: A feature that allows you to manually log call information when you are connected to a call.

Long Tones: A feature that lets you control the length of a tone so that you can signal devices such as fax or answering machines which require tones longer than the standard 120 milliseconds.

M

M7100 telephone: A telephone that has a one-line display and one programmable memory button without an indicator.

M7208 telephone: A telephone that has a one-line display and eight programmable memory buttons with indicators.

M7310 telephone: A telephone that has a two-line display, three display buttons, 10 programmable memory buttons with indicators, and 12 dual-memory programmable buttons without indicators. An M7310 telephone can be equipped with a Busy Lamp Field.

M7324 telephone: A telephone with a two-line display, three display buttons, and 24 programmable memory buttons with indicators. An M7324 telephone can be equipped with a CAP module.

Maintenance: A type of programming your installer or customer service representative can use to diagnose and repair problems in the Norstar system. Maintenance requires no programmable settings.

Memory buttons: The buttons that can be programmed to dial frequently used features or numbers automatically.

Message: A feature that allows you to indicate to another internal user that you would like them to call you.

Mode: See Service Modes.

Mode names: A sub-heading in Administration programming that allows you to assign names to Service Modes. You can use up to seven characters to name a Service Mode.

Mode times: A sub-heading in Administration programming that allows you to assign start and stop times to Service Modes. You can assign different start and stop times for each day of the week.

Move Line buttons: A feature that allows you to move external lines to different buttons on your telephone.

Music source: A radio or other source of music that can be connected to the Key Service Unit to provide music for the Music on Hold and Background Music features. A music source is not part of the Norstar system and must be supplied by the customer.

N

Names: A feature that allows you to assign System Speed Dial numbers, external lines, and telephones in Administration programming. You can use up to sixteen characters to name a System Speed Dial number, and seven characters to name a telephone or line. If a Name has not been assigned, the line number or DN appears on the display instead of a name.

Night Service: See Service Modes.

O

On hold: A setting that controls whether external callers hear music, periodic tones, or silence when they are placed on hold. This setting is programmed by your customer service representative.

Overlay: See Programming overlay.

P

Page: A feature you can use to make announcements over the Norstar system. You can choose Internal Page (announce over the telephone speakers), External Page (announce over an externally-mounted, customer-supplied loudspeaker), or both Internal and External Page.

Page zone: An area in the office that receives internal page announcements independently of the rest of the office. Each page zone is identified by a number. Telephones are assigned to page zones in Administration programming.

Park prefix: See Call park prefix.

Park timeout: A delay before an unanswered parked call returns to the telephone that parked it. Park timeout is set by your customer service representative. See Call Park.

Password: A specific sequence of digits that you enter to gain access to Norstar programming, to override dialing restrictions, or to use Remote Access with DISA. Passwords are also required for System Startup and Administration programming. See Class of Service password.

Pause: A character that inserts a 1.5-second delay in a dialing sequence on an external line.

Personal Speed Dial: A two-digit code (71-94) that can be programmed to dial external telephone numbers. Personal Speed Dial numbers are programmed for each telephone, and can be used only at the telephone on which they are programmed.

Pickup Group: A group of telephones. A telephone can be placed into one of nine Call Pickup Groups. A call ringing at a telephone within a Pickup Group can be picked up at any other telephone within the same Pickup Group. A telephone is assigned to a Pickup Group in Administration programming.

Pool: See Line pool.

Pre-dial: A feature that allows you to enter a number and check it on your telephone display before it is actually dialed. If the number is incorrect, you can edit it. The number is dialed only when you pick up the receiver or select a line.

Prime line: A line on your telephone that is automatically selected when you lift the receiver, press the Handsfree/Mute button or use an external dialing feature. A Prime line is assigned to a telephone by your customer service representative.

Prime telephone (Prime set): A telephone that provides backup answering for incoming calls on external lines. The Prime telephone for a line will ring for any unanswered calls on that line. A Prime telephone is assigned to a line by your customer service representative.

Priority Call: A feature you can use to make a Voice call to a telephone that is idle, busy or has Do Not Disturb activated. This feature is enabled for a telephone in Administration programming.

Privacy: A feature that determines whether a Norstar user may select a line in use at another telephone and join an established call. Privacy is set by your customer service representative, but can be turned on and off by users during individual calls.

Private line: See Private to.

Private network: A telephone network consisting of owned or leased telephone lines used to connect different offices of an organization independently of the public network.

Private to: A line assigned to one telephone as a Private line by your customer service representative. The line cannot appear on any other telephone, except the Prime telephone for that line. Private lines cannot be placed into line pools.

Programming: A series of procedures that set the way the Norstar system works. Programming includes system-wide settings and individual telephone and line settings.

Programming overlay: A paper template that is placed over the top four memory buttons with indicators on the M7310 or M7324 telephone during programming. The overlay labels indicate the special function that each of the four buttons takes on during programming.

Programming reminder: A chart on which you can record some commonly used settings from Administration programming to keep the Norstar system's records up-to-date.

Public line: An external line that can be assigned to any telephone and to many telephones. A line is assigned as Public by your customer service representative.

Public network: The regular telephone network that connects most homes and businesses.

R

Recall: See Link time.

Receiver: The handset of a telephone.

Redirect ring: A subheading in Administration programming that allows you to set whether a line that has been redirected through Line Redirection gives a short ring on those telephones on which the line appears.

Remind delay: A feature that causes a telephone to beep and display the message
On hold: LINENAM when a call has been on hold for a programmable period of time. This period is the Remind delay, and is programmed by your customer service representative.

Remote access: The ability to dial into a Norstar system from outside the system and make use of selected Norstar features. The lines, features, and dialing capabilities available to a remote user are determined by the Class of Service. If the remote access line is answered with DISA, the user must enter a Class of Service password to gain access to the Norstar system's features.

Remote access dial filter: See Remote filter.

Remote access package: A subheading in Administration programming that allows you set up access to Paging and line pools for remote users.

Remote capability: A subset of Norstar features that is available to users connected through Remote Access.

Remote filter: A dialing filter applied to a line in order to control which digits can be dialed during an incoming remote access call. It is the equivalent of a telephone filter for a remote user.

Remote paging: A feature that allows remote users to use the Norstar paging feature. Access to this feature is governed by the Class of Service for the call. See Remote Access and Class of Service.

Remote User: A person who calls into a Norstar system from a telephone outside that system and uses Norstar features or lines. See Remote Access.

Restriction service: A sub-heading in Administration programming that allows you to assign alternate dialing filters for Service Modes. It is also a feature that lets you activate the restriction service part of a Service Mode.

Restrictions: A component of a Dialing filter. Restrictions are numbers you cannot dial when that Dialing filter is in effect. See Exceptions.

Ringling: A programming function done by your customer service representative that assigns a line to ring or not ring at a telephone. If a line has been assigned as "No ring", an incoming call is shown only by a flashing indicator.

Ringling service: A sub-heading in Administration programming that allows you to assign which telephones ring during a Service Mode. It is also a feature that lets you activate the ringling service part of a Service Mode.

Ringling Set: A telephone that has been assigned to ring when a line has been placed into a Service Mode. Ringling telephones are assigned in Administration programming.

RIIs button: A button that ends a call in the same way that hanging up the receiver does. It may also be used to end Startup, Administration programming, Maintenance sessions and feature operations.

Routing service: A sub-heading in Administration programming that allows you to assign alternate call routing for Service Modes. It is also a feature that lets you activate the routing service part of a Service Mode.

Run/Stop: A character that creates a breakpoint in a programmed external dialing sequence. When you press a programmed key, the system dials the number up to the Run/Stop. When you press it again, the system dials the digits following the Run/Stop.

S

SAPS: See Station Auxiliary Power Supply.

Selective line redirection: See Line Redirection

Service Modes: A feature that provides alternate ringling and telephone access, alternate dialing filters, and alternate call routing at different times of the day and on different days of the week. One or more of the alternate services can be activated at a time. Certain features become active when one or more lines or telephones are placed into a Service Mode. Service Modes settings are assigned in Administration programming.

Set: A telephone.

Set ability: A subheading in Administration programming under which set filters, line/set filters, and a variety of system features are assigned to individual telephones.

Set Copy: A heading is Configuration programming that allows you to copy programmable settings from one telephone to another of the same type. Set Copy provides two options: duplicating System Data and User Data, or duplicating System Data only. Set Copy does not provide the same copy capability as COPY, which is more selective of the settings that can be duplicated.

Set filter: See Dialing filter.

Set Names: A subheading in Administration programming that allows you to assign Names of up to seven characters to telephones.

Set Profile: A feature you can use to review the settings that have been programmed by your customer service representative and by yourself in Administration programming. The settings cannot be changed with this feature. Set Profile is available only on the M7310 and M7324 telephones.

Set Relocation: See Automatic Telephone Relocation.

Set lock: A feature that allows you to limit the number of features that may be used or programmed at a telephone. Full telephone lock allows very few changes or features, Partial telephone lock allows some changes and features, and No telephone lock allows any change to be made and any feature to be used. Telephone lock is assigned in Administration programming.

Shift button: A small triangular button beside the dual-memory buttons on the upper half of the M7310 telephone. Press the shift button to store or access features on the top half of the dual-memory buttons.

Show Time: A feature that allows you see the current date and time on the Norstar telephone display while you are on a call.

Startup programming: A procedure that initializes the system programming to defaults. When a Norstar system is first installed and powered up, System Startup must be performed before any programming can be done.

Station: An individual telephone or other Norstar device.

Station Auxiliary Power Supply (SAPS): A device which provides power to a Norstar telephone that is connected more than 305 m (1000 ft) and less than 760 m (2500 ft) from the Key Service Unit, or to a CAP module.

Supervised line: A line for which disconnect supervision is enabled. If an external caller hangs up, the Norstar system detects the disconnection and hangs up its line also.

System coordinator: A person responsible for customizing the Norstar system through Administration programming and for helping co-workers use the Norstar system.

System Data: An option in the Set Copy function. System Data refers to the system settings that apply to all telephones and lines. System Data consists of the programmable settings from System Startup and Administration programming. It also includes the setting programmed by your customer service representative.

System Speed Dial: In Administration programming, a heading under which you can assign up to 70 numbers as System Speed Dial numbers.

System Speed Dial Code: A two-digit code (01 to 70) that can be programmed to dial a telephone number up to 24 digits long. System Speed Dial codes are programmed for the entire Norstar system in Administration programming.

System Speed Dial Name: A subheading in Administration programming under which you can assign a name to a System Speed Dial number.

System Startup: See Startup programming.

T

Tandem call: A call established when a remote user dials into the Norstar system and uses the system to place an outgoing call. The combination of the incoming and outgoing calls forms a tandem call. See Remote Access.

Target line: A line dedicated to receiving calls from outside the Norstar system.

TCM line (Time Compression Multiplexing line): A two-wire digital station loop joining the cross-connect at the Key Service Unit to a telephone.

Time and Date: A display description. The current Time and Date appear on the display of idle Norstar telephones. The Time and Date can be changed in Administration programming.

Transfer: A feature that lets you redirect a call to another telephone in your Norstar system, over a network or outside your Norstar system.

Transfer Callback: A feature that returns a transferred call if it is not answered after a specific number of rings. The number of rings is programmed by your customer service representative. Transfer Callback does not apply to calls transferred externally.

Trunk: A physical connection between the Norstar system and the outside world using either the public telephone system or a private network.

Trunk Answer: A feature you can use to answer a call on any line that has an active Service Mode, even if that line does not appear on your telephone. Trunk Answer is activated in Administration programming.

U

Unsupervised line: A line for which disconnect supervision is disabled. If an external caller hangs up, the Norstar system does not detect the *disconnection and does not hang up* its line. See Disconnect Supervision.

User Data: An option in the Set Copy feature. User Data refers to the personal settings that are unique to an individual telephone, and are not programmed by the customer service representative or Administration programming. User Data is programmed at each telephone. These settings, for example, include Personal Speed Dial and the assignment of *programmable memory buttons*.

User Filter: See Dialing filter.

V

Voice Call: A feature you can use to make an announcement or begin a conversation through the speaker of another telephone in the Norstar system. The telephone you call does not ring. Instead, the person you call hears a beep and then your voice. Their telephone beeps periodically to remind them that their microphone is open.

W

Wait for dial tone: A feature that causes of sequence of numbers to pause until dial tone is present on the line before continuing to dial. The Wait for dial tone symbol (■) uses two of the 24 spaces in a dialing sequence.

Index

Symbols

- § Long Distance symbol 74
- Link symbol 144
- ⊙ Pause symbol 144
- Programmed Release symbol 144
- Run/Stop symbol 145
- Wait for Dial Tone symbol 145

A

- Access denied 104, 108, 134, 150, 166, 178
- accessing
 - external lines 94
 - line pool 80
- Accidental Disconnect Protection 92
- ADD 103
- adjusting display contrast 137
- Administration
 - access code 18
 - password 52
 - programming 1, 13
- Alarm 61-4-2 88
- alarm codes 88
- alarm telephone 88
- allocating log space 53
- Allow calls 140
- Allow redirect
 - programming 39
- Already joined 81, 127
- Already parked 125

- Analog Terminal Adapter
 - dialing modes 139
- answer button 67
- answering the telephone 71
- ATA (see Analog Terminal Adaptor)
- Auto Call Info programming 54
- Auto handsfree programming 37
- Autobumping 118
- Autobumping OFF 122
- Autobumping ON 122
- autodial
 - buttons 69
 - line selection 110
 - programming 108
 - using a line pool 149
- Autodial full 108, 178
- Automatic Dial 138
- Automatic Handsfree 84
- Automatic Hold 142
- Automatic Telephone Relocation 92
- auxiliary ringer programming 38

B

- Background Music 14, 111
- BKSP 16, 103
- busy 80, 165
- busy tone 98
 - fast 99
- Button erased 108
- Button Inquiry 84, 112

- buttons
 - answer 67
 - autodial 69
 - erasing programmed features 85
 - Feature 67
 - for programming 15
 - function inquiry 84
 - Hold 68
 - Last Number Redial 147
 - line 69
 - memory 69
 - moving line 161
 - programmed feature 69
 - programming features 85
 - Release 69
- Bypass restrictions 22
- bypassing
 - a Hotline telephone 90
- C**
- Call 221? 74
- Call blocked 164
- Call Display
 - answering calls on a priority basis 6
 - incoming calls 5
 - options for setup 6
- Call Display Button Cap Kit 124
- Call Display information 71
- Call Duration Timer 113
- Call for you 122
- Call Forward 114
 - and Line Redirection 115, 153
 - No Answer 39, 114
 - on Busy 38, 114
 - overriding 114
 - programming 38, 39
- Call Information 116
- Call Log 7, 118
 - Autobumping 119
 - automatic 55
 - calling from within 120
 - deleting log items 119
 - limiting users 8
 - log space 55
 - logging call manually 119
 - Logit 119
 - options 118
 - password 56, 121
 - sample configurations 8–12
 - using 118
- Call logged 122
- call overflow 95
- Call Park 125
 - prefix 64, 126
- Call Pickup 127
 - directed pickup 127
 - group pickup 127
 - programming reminders 64
- Call Queuing 129
- call routing 51
 - overflow 51
- Call Service programming 54
- Call Services 18
- call transfer 181
- Call transferred 181
- Call(s) bumped 122
- called 158
- Calling 81, 165
- Calls for you 122
- CAMP denied 130
- CAMP max 130
- CAMP to 130
- CAMPed 74, 130
- Camp-on 130
- Can't ring again 81, 167

- Can't send ms9 158
 - CANCEL 103
 - Cancel denied 158
 - Cancel for 158
 - canceling
 - Background Music 111
 - Call Forward 114
 - feature 105
 - CAP (see central answering position)
 - Capabilities 17
 - Capabilities programming 29
 - central answering position 62, 88
 - central office feature codes
 - restricting 30
 - CHANGE 16
 - Class of Service
 - changing 136
 - Class of Service password 43, 136
 - line filter 44
 - programming 43
 - remote access package 44
 - user filter 44
 - Cleared>LINENAM 158
 - clearing a hung line 93
 - Code 148
 - Conf. on hold 134
 - Conference busy 134
 - conference call 132–135
 - by releasing privacy 166
 - creating 132
 - Configuration programming 1, 13
 - Contrast adjustment 137
 - Contrast level 137
 - control telephone 172, 173, 174
 - programming 48
 - controlling
 - remote access 99
 - volume 69
 - COPY 16
 - customizing
 - Call Display services 54
-
- D**
-
- date display 180
 - default
 - dialing filters 31
 - directory number length 18
 - line filters 41
 - remote access packages 33
 - set filter 35
 - deleting
 - Call Log items 119
 - Call Log password 121
 - Denied in admin 104, 127, 148, 162, 164, 175
 - destination code 179
 - dial tone
 - Norstar system 99
 - stuttered 99
 - Dial voice call 185
 - dialing
 - direct-dial telephone 89
 - pulse 87
 - saved number 170
 - tone 87
 - transparent 3
 - within a network 3

- dialing filter
 - changing 92
 - Class of Service password 136
 - creating 30
 - defaults 31
 - exceptions 31
 - feature codes 30
 - for remote callers 41
 - line filter 41, 44
 - line/set filter 35
 - overriding 136
 - programming 30, 50
 - remote user 42
 - restrictions 31
 - set filter 34
 - user filter 44
 - wild card character 30
 - dialing modes 84, 138
 - Automatic Dial 138
 - Pre-Dial 138
 - Standard Dial 138
 - Direct Inward System Access 100
 - Direct-Dial 17
 - direct-dial telephone 64, 77, 89
 - digit 64
 - programming 38
 - direct-dial telephones 27
 - Directed Pickup 127
 - directory numbers 18
 - DISA (see Direct Inward System Access)
 - DISA DN 64
 - display 104
 - adjusting contrast 137
 - language 146
 - time and date 180
 - display buttons
 - equivalents for one-line display 103
 - used for programming 16
 - Display digits 21
 - displaying
 - Call Information 116
 - numbers on telephone 21
 - distinctive rings 168
 - DN (see directory numbers)
 - DND 130
 - DND from 76
 - DND transfer 76
 - Do Not Disturb 140
 - Do not disturb 81, 140, 165, 182
 - DRT 76
-
- E**
-
- emergency telephone 89
 - En español 146
 - En français 146
 - Enter code 85, 178
 - Enter digits 109, 150, 178
 - Enter zone 162
 - entering
 - Administration 18
 - names 19
 - numbers 18
 - Erased> 158
 - erasing
 - Call Log items 120
 - memory button 85
 - Evening 47, 176
 - exception (see dialing filter)
 - Exchanged 161
 - exiting Administration 18
 - Expensive route 81

external autodial
 programming 108
external Call Forward (see Line
 Redirection)
external direct-dial telephone 3
external line access code 64, 78
Extra-0 telephone (see extra-dial
 telephone)
extra-dial telephone
 activating 172
 programming 49

F

F_ 85
fast busy tone 99
feature
 canceling 105
 programmed buttons 69
Feature button 67
Feature code 85
Feature moved 86
Feature timeout 104
1st Display
 programming 56
Forward delay
 programming 39
Forward denied 114
Forward to 114
Forward> 115
forwarding calls 114

G

Get call first 125
Group Listening 141
Group Pickup 127

H

handsfree
 change to regular call 79
 making calls 78
 muting 78
Handsfree Answerback
 programming 37
 Voice Call 185
Handsfree/Mute button 37
headset 67
 using 68
hearing aid compatibility 68
Hidden number 81, 109, 147,
 170
Hold 142
 conference call 132
 exclusive 142
 listening while on hold 142
Hold button 68
Hold or release 86, 109, 122,
 158
host system signaling 144
 Link 144
 Pause 144
 Programmed Release 144
 Run/Stop 145
 Wait for Dial Tone 145
Hotline 90
 bypassing 90
 programming 40
hung lines
 clearing 93

I

In English 146
In use 81, 151, 158
In use SETNAME 122
Inactive feature 104

- incoming line group 95
- incoming line group button 68
- Incoming only** 109, 151
- inquiring about button functions 84
- Intercom** 151
- Intercom #** 109
- internal autodial
 - programming 108
- internal numbers
 - length of 18, 93
- Invalid code** 104, 145, 148, 178
- Invalid location** 161
- Invalid number** 81, 109, 125, 151, 182
- Invalid Password** 136
- Invalid zone** 162
- Item erased** 122
- L**
- language choice 87, 146
- Last Number Redial** 79, 147
- length of call 113
- length of internal numbers 93
- limiting
 - telephone features 36, 96
 - telephone programming 36, 96
- line
 - names 24
 - target 95
- Line 001 waiting** 74
- Line abilities
 - programming 40
- line assignment 94
- line button 69
 - moving 161
- Line denied** 82, 151, 184
- line filter
 - defaults 41
 - programming 41, 44
- Line hung up** 130
- Line in use** 82, 91, 148, 178
- line indicators
 - description 73
- line pool 63, 94
 - access code 80
 - using 148
- Line Profile 58
- Line Redirection 150
 - and Call Forward 115, 153
- Line Redirection** 151
- line selection
 - for a direct-dial telephone 28
 - system speed dial number 21
- line/set filter 35
 - user filter 44
- Line001 callback** 76
- Line001 hung up** 182
- Line001 to Prime** 76
- Line001 transfer** 74
- Link 144
- listening on hold 142
- Log Defaults
 - programming 53
- Log Defaults** 18
- Log is empty** 123
- Log is full** 123
- Log space
 - allocation 53
 - programming 55
- logging a call manually 119
- Logit 7, 119
- Long Tones 155
- Long Tones** 155
- Lunch 47, 176

M

M7100 telephone 103
 Button Inquiry 112
 conference call 135
 operation 105
 User Card 199

M7208 telephone 103
 User Card 202

M7310 telephone 103
 programming overlay 15
 User Card 205

M7324 telephone 103
 programming overlay 15
 two-line display 103
 User Card 208

Make call first 113, 130,
 141, 155, 164, 166, 182

Make calls first 134

Make second call 134

making calls 77
 with Automatic Handsfree
 84

memory buttons 69

Message denied 158

Message for you 159

Message list 159

Message to 159

Messages 12, 156
 cancel sent message 156
 removing from list 157
 sending 156
 viewing 156
 voice messages 12

Messages & Calls 123, 159

Messages for you 159

Microphone muted 185

Miscellaneous 64

Mode 4 47, 176

Mode 5 47, 176

Mode 6 47, 176

monitoring
 calls 67
 line pool status 167
 telephone status 167

mounting telephones on wall 70

Move line from 161

Move line to 161

moving
 line buttons 161
 telephones 92

music
 background 14
 canceling background 111
 listening to 111

Music OFF 111

Music ON 111

muting voice call tones 185

N

name
 entering 19
 lines 24
 Service Modes 46
 system speed dial 22
 telephone 23, 61

Names 17

Need Handsfree 68

New calls begin 123

Night 47, 176

Night Control Phone (see control
 telephone)

Night Ringing Phone (see
 Ringing sets)

Night Service (see Service
 Modes)

Night-0 set (see extra-dial
 telephone)

-
- 9_ 80, 150
 - No button free 82, 127, 148, 159, 184
 - No call on 125
 - No call to park 125
 - No call waiting 129
 - No calls waiting 75
 - No free lines 91, 123, 134, 148
 - No info to log 123
 - No last number 82, 147
 - No line selected 75, 82, 91
 - No line to use 151
 - No log assigned 123
 - No messages 159
 - No new items 123
 - No number saved 82, 170
 - No number stored 159, 178
 - No old items 123
 - No resume item 123
 - No saved number 82, 170
 - No services ON 175
 - No voice call 186
 - Norstar system dial tone 99
 - Not available 104
 - Not in service 75, 82, 115, 131, 182
- O**
-
- OK 103
 - On another call 82, 165
 - On hold 143
 - one button access to features 104
 - one button dialing 108
 - Outgoing line 151
 - overflow call routing 51, 95
 - overlay
 - Call Log 124
 - for programming 15
 - OVERRIDE 103
 - overriding
 - Call Forward 114
- P**
-
- page
 - shortcut codes 163
 - using 162
 - Page choice 162
 - Page timeout 162
 - page zone 61, 63
 - programming 37
 - paging
 - programming 37
 - Paging ALL 162
 - Paging busy 162
 - Park denied 125
 - Parked call 75
 - Parked on 125
 - parking a call 125
 - retrieving 125
 - Parking full 125
 - Password 175
 - password
 - Administration 52
 - Call Log 56, 121
 - Class of Service 43
 - Passwords 17
 - Pause 144
 - Permissions (see Capabilities)
 - personal programming 1, 13
 - Personal Speed Dial 177
 - Pick up receiver 75, 129, 141
 - Pickup 127
 - Pickup denied 127, 184

-
- Pickup group
 - programming 37
 - Please wait 164
 - Pool code 151
 - Pre-Dial 138
 - Press a button 86, 109, 112
 - Press a line 161
 - Press held line 134
 - Press VOLUME bar 169
 - prime telephone 62, 91
 - Prime Telephone User Card 195
 - priority call 164
 - programming 40
 - Priority denied 164
 - Priority>223 75
 - Privacy 166
 - changing status 166
 - Privacy is OFF 166
 - Privacy is ON 166
 - private call 166
 - private line 95
 - Private name 123
 - Private number 123
 - Program and HOLD 86, 109, 178
 - Program and OK 86, 109, 178
 - Programmed 109, 151
 - programmed feature buttons 69
 - Programmed Release 144
 - programming
 - 1st Display 56
 - Administration 13
 - Allow redirect 39
 - Auto Call Info 54
 - Auto handsfree 37
 - Auxiliary ringer 38
 - buttons 15
 - bypass restrictions 22
 - Call Services 54
 - Capabilities 29
 - central answering position 62
 - Class of Service password 43
 - Configuration 13
 - control telephone 48
 - dialing filters 30, 50
 - direct-dial telephone 27
 - direct-dial telephones 38
 - Display digits 21
 - external autodial button 108
 - extra-dial telephone 49
 - Forward delay 39
 - Forward no answer 39
 - Forward on busy 38
 - Handsfree 36
 - HF Answerback 37
 - Hotline 40
 - internal autodial button 108
 - line 59
 - Line abilities 40
 - line filters 41, 44
 - line pool 63
 - Log Defaults 53
 - Log space 55
 - memory button 85
 - Miscellaneous 64
 - overlay 15
 - overview 13
 - page zone 37, 63
 - Paging 37
 - personal 13
 - Personal Speed Dial 177
 - Pickup group 37, 64
 - prime telephone 62
 - priority call 40
 - Redirect ring 39
 - reminders 60–66

remote access packages 32
 remote filters 41
 remote package 42, 44
 Restriction service 50
 reviewing 58
 Ringing service 49
 Routing service 51
 Service Mode names 46
 Service Mode ringing sets
 50
 Service Mode times 47
 Service Modes 65
 Service Modes reminders
 65
 Set abilities 34
 Set lock 36
 Set services 55
 Show external Voice
 Message 55
 Speed Dial # 20
 System Speed Dial 20
 System Speed Dial name 22
 telephone 58
 Time and Date 25
 Trunk Answer 49
 user filter 44
 VMsg centr tel#s 56
 VMsg tel#s lines 57
 Pswd (see Password)
 pulse dialing 87
 switching to tone 87

Q

QUIT 103

R

reallocating log space 53
 redialing
 external number 147
 last number dialed 79
 saved number 80
Redir by 151, 152
 Redirect ring
 programming 39
 redirecting
 a line 150
 redirection loops 153
 refusing to answer second call
 140
Release a call 75, 131
 Release button 69
Release calls 86, 112, 123,
 159
 remote access 97–101
 restricting 32
 remote access packages
 defaults 33
 programming 32
 remote filter
 user filter 44
 remote package
 programming 42, 44
 remote access package 44
 remote use
 Class of Service password
 43
 removing
 yourself from conference
 133
 replying to a message 157
Restr'n 175
Restricted call 82, 152, 182

-
- restricting
 - line at telephone 35
 - lines 41
 - remote access 32, 36
 - remote callers 41
 - remote feature use 42
 - telephone programming 36
 - telephones 34
 - restriction
 - overriding 136
 - restriction (see dialing filters)
 - Restriction password (see Class of Service Password)
 - Restriction service 4, 171, 173
 - programming 50
 - retrieval codes
 - Call Park 126
 - retrieving
 - held call 142
 - parked call 125
 - voice messages 56
 - Ring Again
 - using 167
 - Ring Again? 82, 167
 - Ring type 168
 - Ring type 1 168
 - Ring volume 169
 - Ringing 175
 - Ringing service 4, 171, 172
 - extra-dial telephone 172
 - programming 49
 - rings
 - choosing type 168
 - description 73
 - RLS button 69
 - Routing 175
 - routing
 - overflow 51
 - Routing service 4, 171, 173
 - programming 51
 - Run/Stop 145
- S**
-
- Saved Number Redial 80, 170
 - security
 - system 99
 - Select a line 83, 178
 - Select line out 152
 - Select line(s) 152
 - Send message? 83
 - Service Modes 45, 65, 171–176
 - Evening 47, 176
 - extra-dial telephone 172
 - Lunch 47, 176
 - Mode 4 47, 176
 - Mode 5 47, 176
 - Mode 6 47, 176
 - Night 47, 176
 - programming names 46
 - programming ringing sets 50
 - programming times 47
 - Restriction service 4, 171, 173
 - 173
 - Ringing service 4, 171, 172
 - Routing service 4, 171, 173
 - start and stop times 47
 - Trunk Answer 184
 - viewing active 174
 - Service Modes 17
 - Service Modes ON 176
 - Set abilities
 - programming 34
 - set filter
 - default 35
 - user filter 44
 - Set lock 96
 - programming 36
-

Set locked 104
 Set Profile 58
 Set services
 programming 55
SHOW 103
 Show external Voice Message
 programming 55
 Show extl VMsg (see Show
 external Voice Message)
 Speed Dial 80, 177
 host system signaling codes
 21, 179
 making a call 177
 programming Personal 177
 using a line pool 149
Speed dial 178
 Speed dial # 20
 splitting a conference 133
 Standard Dial 138
Standard dial 138
 start and stop times
 Service Modes 47
Start of list 159
Still in transfer 182
 stopping calls from ringing at
 your telephone 140
 stuttered dial tone 99
Sys speed dial 17
 system dial tone 99
 System Speed Dial 20, 177
 bypass restrictions 22
 Display digits 21
 Name 22

T

target line 95
 telephone
 Administration Lock 96
 answering 71
 Call Display information 54
 central answering position
 88
 direct-dial 89
 emergency 89
 hotline 90
 log calls automatically 55
 mounting on wall 70
 names 23
 prime 91
 programming reminder 61
 voice message waiting
 indication 55
 Telephone Feature Card 188
Their list full 159
3 Parties only 134
 Time and Date 25, 180
Time and date 17
 time display 180
 tone
 controlling length 155
 dialing 87
 voice call 185
 Transfer 181
Transfer denied 182
Transfer to 182
 transparent dialing 3
 Trunk Answer 184
 programming 49

U

Unequipped line 152
 Unknown call 122
 Unknown name 122
 Unknown number 178
 until * 175
 Use line pool? 75
 User Card
 M7100 telephone 199
 M7208 telephone 202
 M7310 telephone 205
 M7324 telephone 208
 Prime Telephone 195
 Telephone Features 188
 user filter
 programming 44
 using a headset 68
 using Norstar remotely 97-101

V

VIEW 16, 103
 viewing
 active Service Modes 174
 Call Log 119
 VMsg centr tel#s (see Voice
 Message center telephone
 numbers)
 VMsg tel#s lines (see Voice
 Message telephone numbers
 lines)
 Voice call 186
 voice call 80, 185
 Voice Message center
 telephone lines 57
 telephone numbers 56
 voice message waiting indication
 55
 voice messages 12

volume

bar 69
 control 69
 level in conference call 135
 ring 169

W

Wait for Dial Tone 145
 wall mounting telephones 70
 wild card character 30

Y

Your list full 159
 Your number 83

